

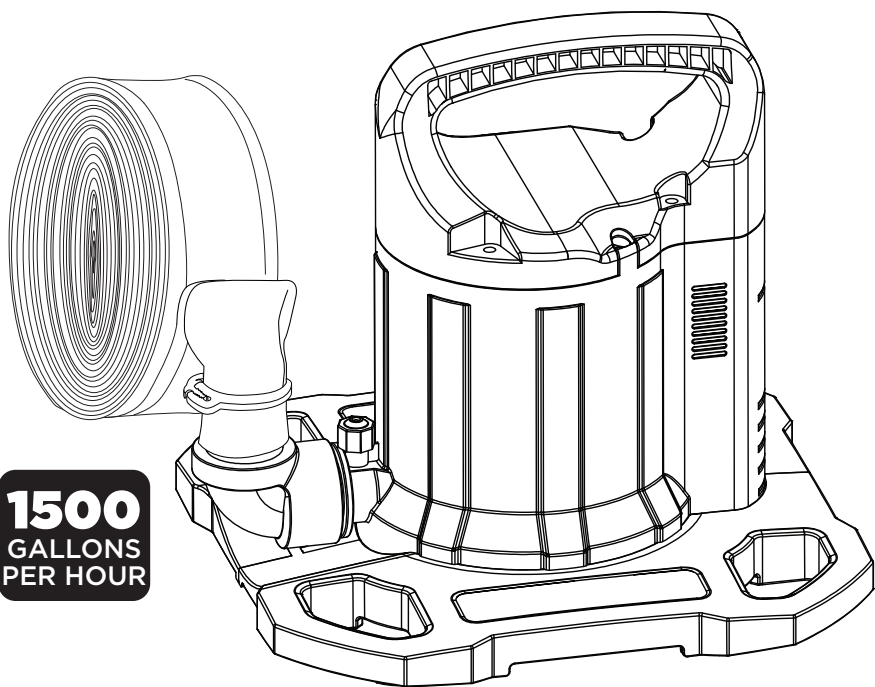

# 1500 GPH COVER PUMP INSTRUCTION MANUAL

MODEL NUMBER  
AC 20745



**1500**  
GALLONS  
PER HOUR

Thank you for choosing Old Man Winter!  
PLEASE READ BEFORE RETURNING THIS  
PRODUCT FOR ANY REASON.  
SAVE THIS MANUAL FOR FUTURE  
REFERENCE.

## SAFETY GUIDELINES — DEFINITIONS

It is important for you to read and understand this manual. The information it contains relates to protecting YOUR SAFETY and PREVENTING PROBLEMS. The symbols below are used to help you recognize this information.

 **DANGER:** Indicates an imminently hazardous situation which, if not avoided, will result in death or serious injury.

 **WARNING:** Indicates a potentially hazardous situation which, if not avoided, could result in death or serious injury.

 **CAUTION:** Indicates a potentially hazardous situation which, if not avoided, may result in minor or moderate injury.

**NOTICE:** Used without the safety alert symbol indicates potentially hazardous situation which, if not avoided, may result in property damage.

## IMPORTANT SAFETY INSTRUCTIONS

When using an electrical appliance, basic precautions should always be followed, including the following:

### READ ALL INSTRUCTIONS BEFORE USING THIS COVER PUMP

 **WARNING:**  
**Read all safety warnings and all instructions.** Failure to follow the warnings and instructions listed below may result in electric shock, fire and/or serious injury

 **WARNING:**  
**To reduce the risk of fire, electrical shock or injury:**

- Do not allow to be used as a toy. Close attention is necessary when used by or near children.
- Use only as described in this manual.

- Do not use with damaged cord or plug. If appliance is not working as it should, has been dropped, damaged, left outdoors or dropped into water, return it to a service center
- Do not pull or carry by cord, use cord as a handle, close a door on cord, or pull cord around sharp edges or corners. Do not run appliance over cord. Keep cord away from heated surfaces.
- Do not unplug by pulling on cord. To unplug, grasp the plug, not the cord.
- Do not put any object into openings. Do not use with any opening blocked.
- Keep hair, loose clothing, fingers and all parts of body away from opening and moving parts.
- This appliance is intended for household use only and not for commercial or industrial use.
- Use only in a standard electrical outlet (120V/60Hz).

# ASSEMBLE THE BASE TO PUMP

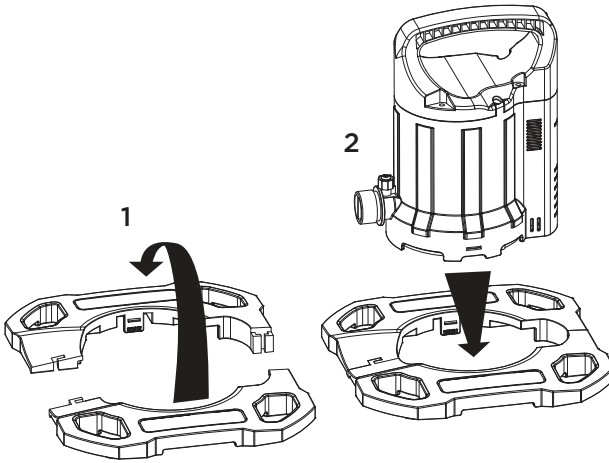

## PREPARATION:

### ⚠ WARNING:

1. Always use a properly GFCI protected outlet. (See figure #2)
2. The National Electrical Code requires that a Ground Fault Circuit Interrupter (GFCI) be installed in the branch circuit supplying the outlet that this Pump is plugged into.
3. Do not immerse plug into water.
4. DO NOT REACH INTO WATER TO REMOVE PLUG. TURN OFF CIRCUIT FIRST.
5. A drip loop should be provided. The drip loop is a loop in the cord below the level of the receptacle that prevents water from traveling along the cord. (See figure #3)

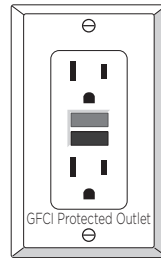

Figure #2

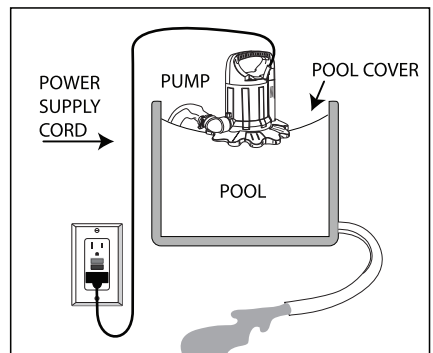

Figure #3

**6. NEVER REMOVE THE GROUND PIN FROM PLUG.** (See figure #4)

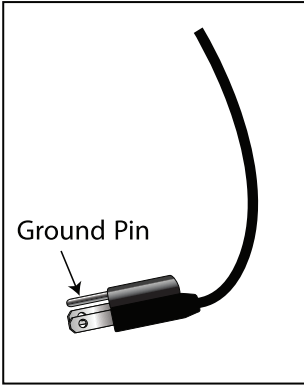

Figure #4

**⚠ WARNING:**

For your protection always unplug the unit from its power source before installing or servicing. Should the unit appear not to be working DO NOT REACH, REMOVE, or DISASSEMBLE UNIT before you DISCONNECT POWER.

**⚠ WARNING:**

This pump is intended to pump water only. It cannot be used to pump oils, solvents or gasoline.

# CARE AND OPERATING INSTRUCTIONS

- This is a submersible, magnetically driven centrifugal pump that is designed specifically for the purpose of removing water off the top of swimming pool covers. Pump should only be used for this application.
- This pump is equipped with a collapsible discharge hose used to direct waste water away from the pool.
- This pump is equipped with a pre-filter pad, designed to prevent debris from clogging the pump. This filter pad should be washed clean regularly.
- To avoid permanent damage never run pump dry.

## PREPARATION:

1. Remove cover pump from box.
2. Unwind cord making sure that the plug stays dry at all times.
3. Make sure hose is securely clamped to the pump.
4. Submerge the pump in the deepest area of water on your winter cover.
5. Direct the open end of the hose away from the pool.
6. Plug in the pump.

# ROUTINE MAINTENANCE:

1. Filter pad should be replaced annually.
2. Remove pump from pool after each use.
3. Disconnect and drain garden hose.
4. Remove, clean and replace filter pad after each use

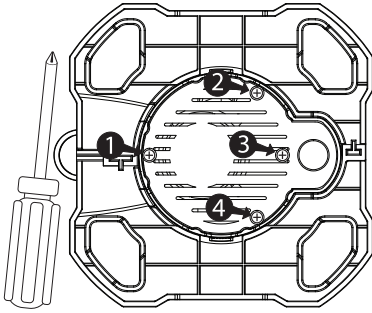

Remove Four Screws

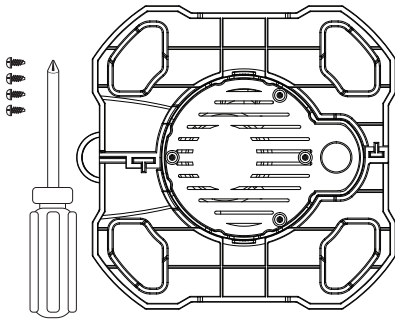

Remove Four Screws

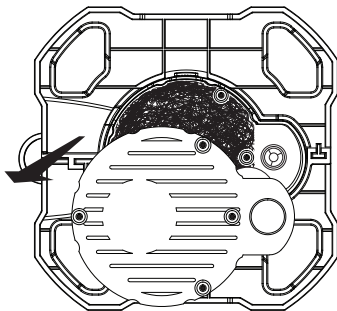

Gently Remove Bottom Plate

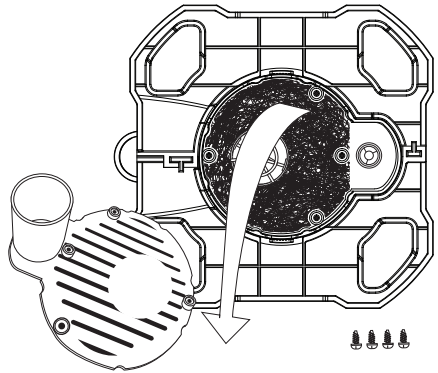

Bottom Plate Removed

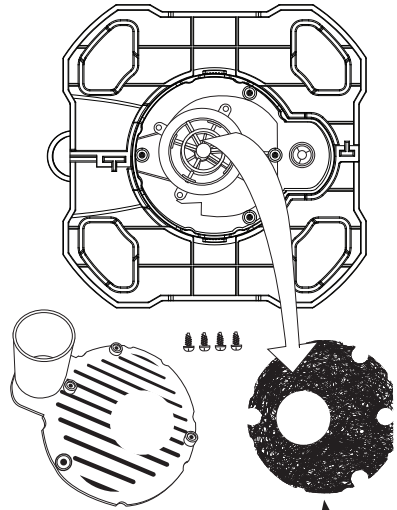

Bottom Plate Removed

Reusable Filter Pad

## ⚠ CAUTION:

To avoid damaging pump never leave pump submerged in water that may freeze. Allowing ice to form inside the pump chamber will permanently damage the pump.

# 1 YEAR LIMITED WARRANTY

Blue Torrent warranties this product to be free from defects in material or workmanship of a period of < 2 ( ) year following the date of purchase, provided that the product is used in a home environment. This limited warranty does not cover failures due to abuse, accidental damage or when repairs have been made or attempted by anyone other than Blue Torrent and its Authorized Service Centers. A defective product meeting the warranty conditions set forth herein will be replaced or repaired at no charge in either of two ways:

The first, which will result in exchanges only, is to return the product to the retailer from whom it was purchased (provide that the store is a participating retailer). Returns should be made with the time period of the retailer's policy for exchanges. Proof of purchase may be required. Please check with the retailer for its specific return policy regarding time limits for returns or exchanges. The second option is to take or send the product (prepaid) to Pump Service Center for repair or replacement.

**Blue Torrent LLC.**  
**(888) 901-3785**  
**1075 Hicksville Road**  
**Seaford, NY 11783 U.S.A.**  
**warranty@bluetorrentpoolproducts.com**  
**service@bluetorrentpoolproducts.com**

This warranty does not apply to accessories. This warranty gives you specific legal rights and you may have other rights which vary from state to state. Should you have any questions, contact the manager of the pump service center listed above.

This product is not intended for commercial use, and accordingly, such commercial use of this product will void this warranty. All other guarantees, express or implied, are hereby disclaimed. **LATIN AMERICA:** This warranty does not apply to products sold in Latin America. For products sold in Latin America, check country specific warranty information contained in the packaging, call the local company or see the D ebsite for such information **FREE WARNING LABEL REPLACEMENT** If your warning labels become illegible or are missing, call 1-888-901-3785 for a free replacement.

Manufactured for  
Blue Torrent  
444 E 81 St St.  
New York, NY 10028-5859

Warranty must be registered at [bluetorrentpoolproducts.com](http://bluetorrentpoolproducts.com). Scan QR code below or visit [bluetorrentpoolproducts.com/register](http://bluetorrentpoolproducts.com/register) to register your warranty.

