

# CARTRIDGE FILTER OPERATING INSTRUCTION

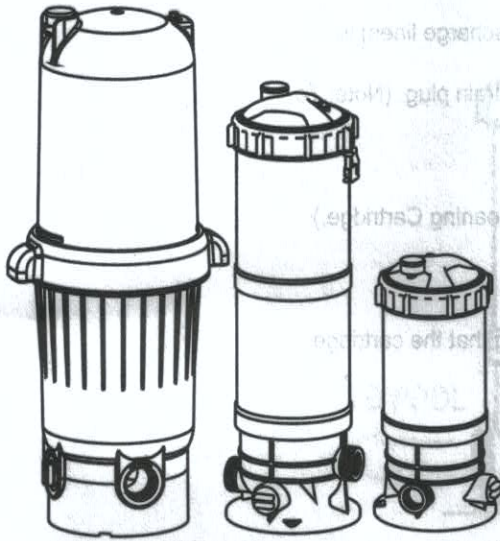

## FILTER LOCATION

It is important to first determine where your pump and filter will be located. If above the water line, a self-priming pump must be used. Self-priming pumps have the ability to lift water from a lower level and prime automatically.

1. Since plumbing fittings offer a resistance to water flow, position the filter as close to the swimming pool as local codes allow. Keep the number of fittings to a minimum. Select a well drained area, one that will not flood when it rains.
2. Set the filter on a solid, level surface. Be sure filter, pump, drain and pressure gauge are accessible for convenient operation.
3. Position the filter so the tank can drain by gravity.
4. If practical, place pump and filter in the shade to shield it from continuous, direct heat from the sun

## PLUMBING

1. Use 1-1/2" or 2" piping. When making permanent connections, be sure to provide unions for easy servicing.
2. Refer to the diagrams for basic suggested valving. Ball valves are recommended where needed. While all systems vary, the main consideration is to provide the desired control of water flow from the pool to the pump and filter, and back to the pool. When the filter is located below water level, provide valves to prevent back flow of water to the filter during cleaning and routine servicing.
3. All plumbing on the Star-Clear Plus filter are 1-1/2" or 2" N.P.T. or socket (solvent weld). When making threaded connections to the filter use plastic adapters. Apply three turns of Teflon tape (or use special plastic pipe sealant) to male threads. Screw the fitting into the thread hand tight; then using a wrench, tighten one more full turn. Additional tightening is unnecessary and result in broken or damaged fittings
4. Connect the pool suction plumbing between the skimmer, pool outlet, etc. and the pump.
5. Install the pool return plumbing.
6. If pressure gauge is not installed, apply Teflon tape to the gauge threads, and carefully screw the gauge into the threaded hole in the filter head.
7. A filter drain plug is furnished with each filter and is all that is needed for complete filter draining. A manual air relief valve is furnished to aid in bleeding off unwanted air when starting the filter. The auto air relief provides air removal during operation.
8. All electrical connections should be made in accordance with local codes.
9. Check for joint leaks before operating.
10. Refer to pump instruction booklet for pump information.

## STARTING THE FILTER

Be sure filter drain plug is closed. Open manual air relief valve a few turns and open the suction and return valves

(when used). CAUTION: All suction and discharge valves must be open when starting the system.

Failure to do so could cause severe personal injury and/or property damage. Be sure locking knob is secure (hand tighten—only slight pressure is required).

Stand clear of the filter and prime and start the pump, following the manufacturer's instructions.

Air trapped in the system will automatically vent to the pool and out air relief valve. Close air relief valve as soon as air is vented.

## FILTERING

Filtration starts as soon as flow is steady through the filter. As the filter cartridge removes dirt from the pool water, the accumulated dirt causes a resistance to flow. As a result, the gauge pressure will rise and the flow will decrease.

When the pressure rises 7-10 psi (.49-.70 Bar) above the starting pressure, or when flow decreases below desired rate, clean or replace the filter cartridge.

## CLEAN/REPLACE CARTRIDGE

### Removing Cartridge Element

1. Shut off the pump.
2. If filter is located below water level, close valves (or block off suction and discharge lines) to prevent backflow of water from the pool.
3. Unscrew and remove drain plug and allow water to drain from filter. Close drain plug. (Note: To assist draining process: open air vent a few turns.)
4. Unscrew and remove locking knob (counterclockwise direction).
5. Carefully lift off top cover to gain access to filter cartridge.
6. Lift out cartridge and clean. Or, replace with clean, spare cartridge. (See Cleaning Cartridge.)

### Reinstalling Cartridge Element

1. Clean any collected debris from the bottom of filter body.
2. Carefully replace cartridge element over tie rod and into filter body ensuring that the cartridge sits evenly on the collector hub in bottom of filter body.
3. Tighten locking knob in clockwise direction. (Hand tight only.)
4. Proceed as in STARTING THE FILTER.

### Cleaning Cartridge

The cartridge filter element can be cleaned by pressure washing inside and out with a garden hose. (The cartridge is easier to clean when dry.) After hosing the cartridge, for best results, allow cartridge to dry and carefully brush pleated surface areas to remove fine particles.

Algae, suntan oil and body oils can form a coating on the cartridge pleats which may not be thoroughly removed by hosing. To remove such materials, soak the cartridge in a solution of filter element cleaner (various brands available at pool dealer). Follow manufacturer's directions for use and allow an hour for soaking. Hose thoroughly before reinstalling in filter.

If calcium or mineral deposits are excessive, the cartridge may be restored to "like new" condition by soaking in muriatic acid. Use commercially available 20% muriatic acid added to water in 1 to 1 ratio.

Use a plastic container and take extreme care when handling cleaning agents as they can be harmful to eyes, skin and clothing. After cleaning, flush with water.

A spare cartridge filter element is an excellent investment. It provides convenience and ensures that your filter will always be ready to operate at peak efficiency.

### WINTERIZING (Filter)

In areas where sub-freezing temperatures can be expected, the filter should be drained and/or removed from its operating location and stored indoors. Remove and clean cartridge. Reinstall cartridge in filter tank. Tighten locking knob only a few turns when storing.

### FILTER SPECIFICATION

| Model no.                 | 73110             | 73111             | 73112             | 73113             | 73114              | 73115              | 73103001           | 73103002           | 73103000           |
|---------------------------|-------------------|-------------------|-------------------|-------------------|--------------------|--------------------|--------------------|--------------------|--------------------|
| Effective Filtration area | 25FT <sup>2</sup> | 35FT <sup>2</sup> | 50FT <sup>2</sup> | 70FT <sup>2</sup> | 100FT <sup>2</sup> | 120FT <sup>2</sup> | 120FT <sup>2</sup> | 150FT <sup>2</sup> | 200FT <sup>2</sup> |
| Design-flow rate          | 25GPM             | 35GPM             | 50GPM             | 70GPM             | 90GPM              | 110GPM             | 110GPM             | 130GPM             | 150GPM             |
| Maximum working pressure  | 50PSI<br>3.5BAR   | 50PSI<br>3.5BAR   | 50PSI<br>3.5BAR   | 50PSI<br>3.5BAR   | 50PSI<br>3.5BAR    | 50PSI<br>3.5BAR    | 50PSI<br>3.5BAR    | 50PSI<br>3.5BAR    | 50PSI<br>3.5BAR    |

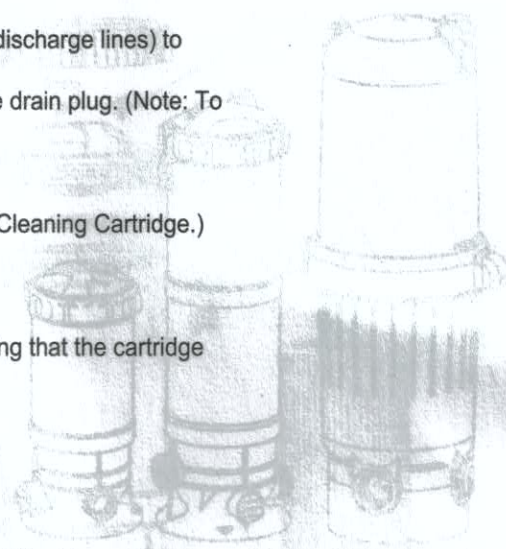

| NO. | PSRT NO.    | DESCRIPTION                 | QTY   |     |             |                             |   |
|-----|-------------|-----------------------------|---|-----|-------------|-----------------------------|---|
| 1   | 47311001    | Locking ring                | 1   |     |             |                             |   |
| 2   | 5024002000  | Pressure gauge              | 1   |     |             |                             |   |
| 3   | 47311004    | Seal cover                  | 1   |     |             |                             |   |
| 4   | 5431045080  | O-ring                      | 1   |     |             |                             |   |
| 5a  | 5022001000  | Body73110                   | 1   |     |             |                             |   |
| 5b  | 5022002000  | Body73111                   | 1   |     |             |                             |   |
| 5c  | 5022003000  | Body73112                   | 1   |     |             |                             |   |
| 5d  | 5022004000  | Body73113                   | 1   |     |             |                             |   |
| 6   | 49121501    | Plug w/o-ring 1/2"          | 1   |     |             |                             |   |
| 7   | 5431021080  | O-ring                      | 1   |     |             |                             |   |
| 8   | 48860105    | Drain plug with gasket      | 1   |     |             |                             |   |
| 9   | 5432002080  | Gasket                      | 1   |     |             |                             |   |
| 10  | 47311008    | Safty plug                  | 1   |     |             |                             |   |
| 11  | 47311009    | Locking Iring latch         | 1   |     |             |                             |   |
| 12a | 65022001000 | Cartridge element for 73110 | 1   |     |             |                             |   |
| 12b | 65022001000 | Cartridge element for 73111 | 1   |     |             |                             |   |
| 12c | 65022001000 | Cartridge element for 73112 | 1 </tr <tr> <td>12d</td> <td>65022001000</td> <td>Cartridge element for 73113</td> <td>1</td> </tr> | 12d | 65022001000 | Cartridge element for 73113 | 1 |
| 12d | 65022001000 | Cartridge element for 73113 | 1   |     |             |                             |   |

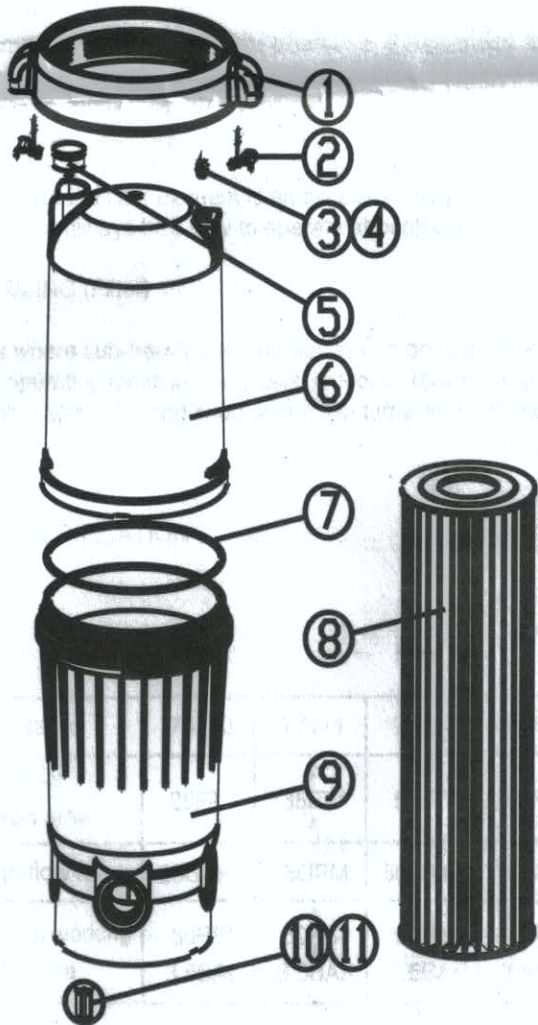
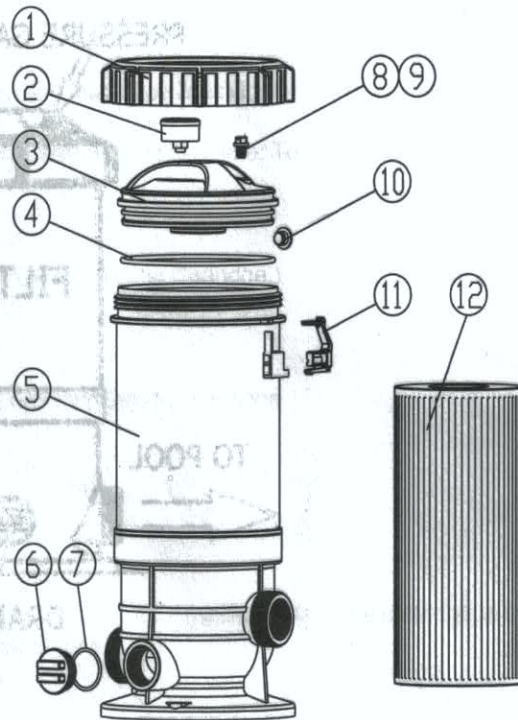

| NO. | PSRT NO.     | DESCRIPTION                    | QTY |
|-----|--------------|--------------------------------|-----|
| 1   | 47310303080  | Locking ring                   | 1   |
| 2   | 47310304080  | Locking Iring latch            | 1   |
| 3   | 48860105     | Drain plug with gasket         | 1   |
| 4   | 5432002080   | Gasket                         | 1   |
| 5   | 5024002000   | Pressure gauge                 | 1   |
| 6   | 47310302080  | Seal cover                     | 1   |
| 7   | 5431093080   | O-ring                         | 1   |
| 8a  | 5022035000   | Cartridge element for 73103000 | 1   |
| 8b  | 5022036000   | Cartridge element for 73103001 | 1   |
| 8c  | 5022037000   | Cartridge element for 73103002 | 1   |
| 9   | 473103010804 | Body                           | 1   |
| 10  | 9102607080   | Plug w/o-ring 2"               | 1   |
| 11  | 5431030080   | O-ring                         | 1   |