

IMPORTANT SAFETY RULES

Read, understand, and follow all instructions carefully before installing and using this product.

C530

Krystal Clear™ Filter Pump
Certified Model Number 603

C1000

Krystal Clear™ Filter Pump
Certified Model Number 637R



For illustrative purposes only.

Don't forget to try these other fine Intex products: Pools, Pool Accessories, Inflatable Pools and In-Home Toys, Airbeds and Boats available at fine retailers or visit our website listed below. Due to a policy of continuous product improvement, Intex reserves the right to change specifications and appearance, which may result in updates to the instruction manual without notice.

INTEX®

IMPORTANT! DO NOT RETURN PRODUCT TO STORE

To purchase parts and accessories or to obtain non-technical assistance, Visit

www.intexcorp.com

For technical assistance, missing parts or warranty claims call (for U.S. and Canadian Residents):

1-310-549-8235

Monday through Friday, 8:30am to 5:00pm Pacific Time

057-***-R0-2304

TABLE OF CONTENTS

| | |
|-------------------------------------|------------|
| Warnings..... | 3 |
| Parts Reference..... | 4 |
| Setup Instructions..... | 5-6 |
| Timer Operation..... | 6-7 |
| Maintenance..... | 8 |
| Pool Care and Chemicals..... | 8 |
| Long Term Storage..... | 8 |
| Troubleshooting Guide..... | 9 |
| Common Pool Problems..... | 10 |
| General Aquatic Safety..... | 11 |
| Limited Warranty..... | 12 |

This device complies with part 15 of the FCC Rules. Operation is subject to the following two conditions: (1) This device may not cause harmful interference, and (2) this device must accept any interference received, including interference that may cause undesired operation.

WARNING: Changes or modifications not expressly approved by the party responsible for compliance could void the user’s authority to operate the equipment.

NOTE: This equipment has been tested and found to comply with the limits for a Class B digital device, pursuant to part 15 of the FCC Rules. These limits are designed to provide reasonable protection against harmful interference in a residential installation. This equipment generates, uses and can radiate radio frequency energy and, if not installed and used in accordance with the instructions, may cause harmful interference to radio communications. However, there is no guarantee that interference will not occur in a particular installation. If this equipment does cause harmful interference to radio or television reception, which can be determined by turning the equipment off and on, the user is encouraged to try to correct the interference by one or more of the following measures:

- Reorient or relocate the receiving antenna.
- Increase the separation between the equipment and the receiver.
- Connect the equipment into an outlet on a circuit different from that to which the receiver is connected.
- Consult the dealer or an experienced radio/TV technician for help.

IMPORTANT SAFETY RULES

Read, Understand and Follow All Instructions Carefully Before Installing and Using this Product.

READ AND FOLLOW ALL INSTRUCTIONS

WARNING

- To reduce the risk of injury, do not permit children to use this product. Always supervise children and those with disabilities.
- Children must stay away from this product and electrical cord(s).
- Assembly and disassembly by adults only.
- Risk of electric shock. Connect only to a grounding type receptacle, this product is provided with a ground-fault circuit interrupter. If replacement of the plug or cord is needed, use only identical replacement parts.
- Always unplug this product from the electrical outlet before removing, cleaning, servicing or making any adjustment to the product.
- The unit is provided with a ground-fault circuit interrupter (GFCI). To test the GFCI, push the test button. The GFCI should interrupt power. Push the reset button, power should be restored. If the GFCI fails to operate in this manner. The GFCI is defective. If the GFCI interrupts power to the pump without the test button being pushed, a ground current is flowing, indicating the possibility of an electric shock. Do not use this pump. Disconnect the pump and have the problem corrected by a qualified service representative before using.
- Do not bury the electrical cord. Locate the cord where it will not be damaged by lawn mowers, hedge trimmers and other equipment.
- To reduce the risk of electric shock, the supply cord cannot be replaced. If the cord is damaged, the appliance should be replaced immediately.
- To reduce the risk of electric shock, do not use extension cords, timers, plug adaptors or converter plugs to connect unit to electric supply; provide a properly located outlet.
- Do not attempt to plug in or unplug this product while standing in water or when your hands are wet.
- Do not use an appliance leakage current interrupter (ALCI) in place of a GFCI since the ALCI will not protect people.
- Position this product away from the pool, so as to prevent children from climbing on it and accessing the pool.
- Make sure the electrical parameters indicated on the product correspond to the local mains voltage before you connect the unit.
- This product is intended to be used only for the purposes described in the manual!

FAILURE TO FOLLOW THESE WARNINGS MAY RESULT IN PROPERTY DAMAGE, ELECTRIC SHOCK, ENTANGLEMENT OR OTHER SERIOUS INJURY OR DEATH.

CAUTION

This product is for use with storable pools only. Do not use with permanently-installed pools. A storable pool is constructed so that it is capable of being readily disassembled for storage and reassembled to its original integrity. A permanently-installed pool is constructed in or on the ground or in a building such that it cannot be readily disassembled for storage.

To reduce the risk of electric shock the pool must be installed no closer than 6 feet (1.8 m) from any electrical outlet. Do not place portable appliances closer than 5 feet (1.5 m) from the pool.

These product warnings, instructions and safety rules provided with the product represent some common risks of water recreation devices and do not cover all instances of risk and danger. Please use common sense and good judgement when enjoying any water activity.

SAVE THESE INSTRUCTIONS

PARTS REFERENCE

Before assembling your product, please take a few minutes to check the contents and become familiar with all the parts.

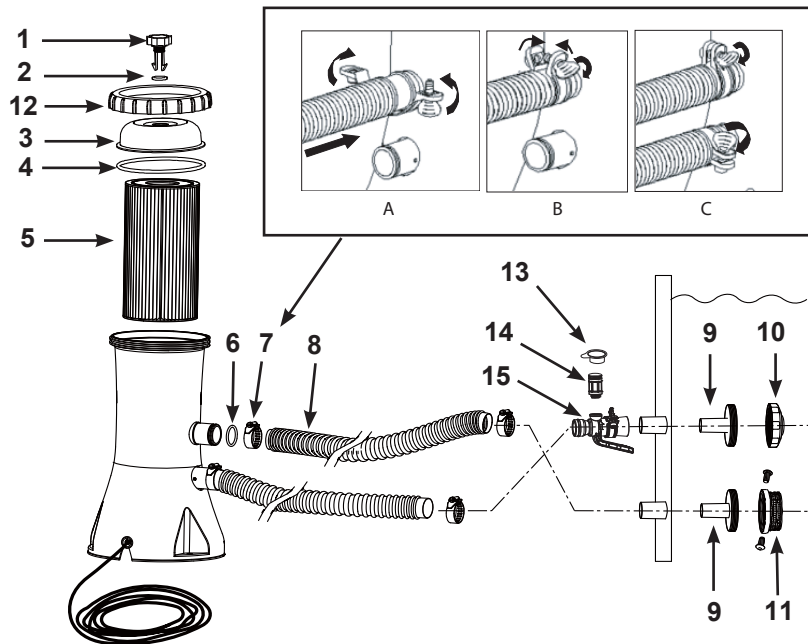

NOTE: Drawings for illustration purpose only. May not reflect actual product. Not to scale.

| REF. NO. | DESCRIPTION | QTY. | SPARE PART NO. | |
|----------|--------------------------------|------|----------------|------------|
| | | | Model 603 | Model 637R |
| 1 | AIR RELEASE VALVE | 1 | 10460 | 10460 |
| 2 | VALVE O-RING | 1 | 10264 | 10264 |
| 3 | FILTER HOUSING COVER | 1 | 11868 | 11868 |
| 4 | COVER SEAL | 1 | 10325 | 10325 |
| 5 | FILTER CARTRIDGE | 1 | 29000 | 29000 |
| 6 | HOSE SEAL | 2 | 10134 | 10134 |
| 7 | HOSE CLAMP | 4 | 11489 | 11489 |
| 8 | HOSE | 2 | 10116 | 10116 |
| 9 | STRAINER CONNECTOR | 2 | 11070 | 11070 |
| 10 | POOL INLET JET NOZZLE | 1 | 13162 | 13162 |
| 11 | STRAINER GRID | 1 | 11072 | 11072 |
| 12 | THREADED FILTER HOUSING COLLAR | 1 | 11869 | 11869 |
| 13 | AIR JET VALVE CAP | 1 | 12373 | 12373 |
| 14 | AIR JET VALVE | 1 | 12363 | 12363 |
| 15 | POOL INLET AIR ADAPTOR | 1 | 12367 | 12368 |

When ordering parts, be sure to quote the model number and part numbers. No tools are required for the assembly.

SETUP INSTRUCTIONS

Be sure you have access to water to fill the pool and chemicals for the water.

IMPORTANT: This filter pump is shipped with the air release valve (1) open (open the air release valve if necessary). DO NOT replace the air release valve until you reach STEP #8. Failure to follow these instructions will result in air trapped inside filter housing; the motor will run dry, be noisy and malfunction.

1. Assemble above-ground-pool first. Carefully follow the pool's installation instructions.
2. Place the filter pump the length of the hose away from the pool wall where the lower black protruding hose connection is "sticking-out".
3. Insert the nozzle union (9 & 10) into the upper protruding hose connections, and then attach the pool inlet air adaptor (15) to the upper protruding fitting. Screw the air jet valve (14) over the pool inlet air adaptor (15). Then insert the strainer union (9 & 11) into the lower protruding hose connections. The hoses (8) fit over the strainers inserted into the connections.
4. There are two hoses to be connected to the filter pump hose connections. With hose clamps (7), fasten one of the hoses (8) to the lower protruding hose connection (marked "+" on the pool liner) and to the upper pump connection (marked "+").
5. Connect the second hose to the pool inlet air adaptor (15) and to the lower pump connection. Make sure all the hose clamps (7) are tight. **NOTE: Make sure the air jet valve (14) is securely tighten onto the pool inlet air adaptor (15) and facing up.**
6. In a counter-clockwise motion unscrew the threaded filter housing collar (12) from the filter housing. Grasp and remove the threaded cover (3). Check to see if a cartridge is inside the housing. If yes, replace the cover, finger tighten the housing collar (12) back onto the filter housing.
7. Fill the pool to a level of at least 1-2 inches above the top connection. The water will automatically flow down into the pump.
8. When water starts flowing out of the air release valve hole, screw in the air release valve back into the filter housing cover. Do not over tighten the valve. **NOTE: Venting the system is necessary for air to escape as the filter housing fills with water.**
9. Connect the filter pump to the power outlet and set the timer dial on the GFCI to the desired operating hours. See the "Operating Time Table" section for the required operating hours related to each pool size.
Note: If the End of Life (EOL) indicator on the GFCI plug is flashing, do not use the product. Disconnect the product and have the GFCI plug replaced by a qualified electrician before using.
10. Operate the filter pump until the desired water clarity is obtained.
Note: Never put pool chemicals directly into the filter pump. This may damage the pump and void the warranty.

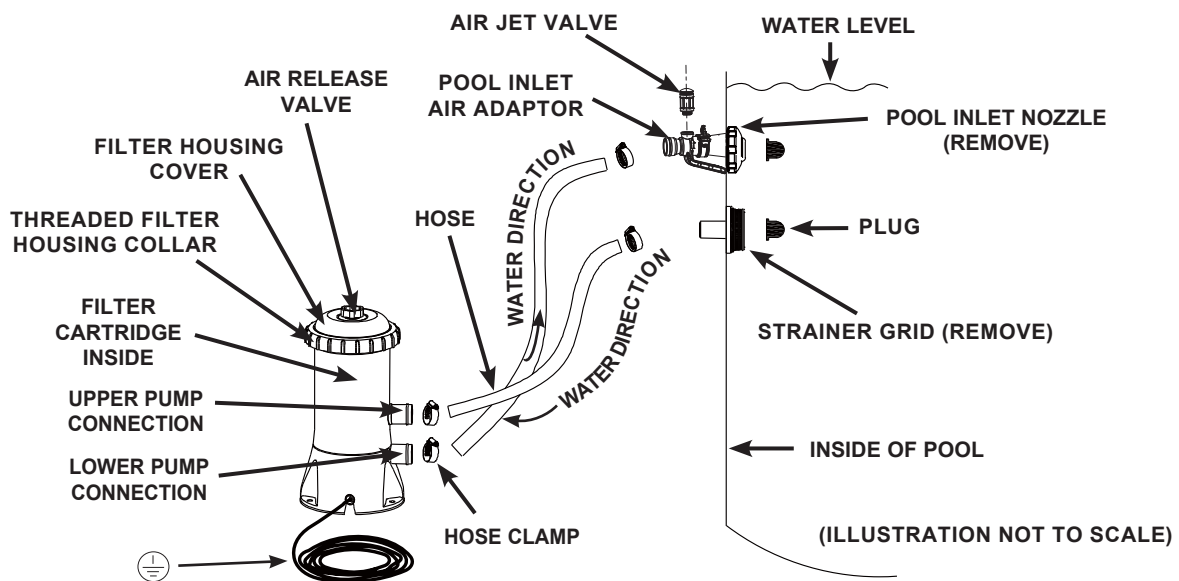

SETUP INSTRUCTIONS (CONTINUED)

For Pools with Dual Suction Outlets Configuration:

In order to comply with the requirement of the Virginia Graeme Baker Act (for USA and Canada), your pool is designed with dual suction outlets and one inlet fittings. Parts in grey highlight on this page are supplied with the pool set package and are shown here for assembly purposes only. If this pump was purchased as part of a pool set, refer to the pool owner's manual for more details.

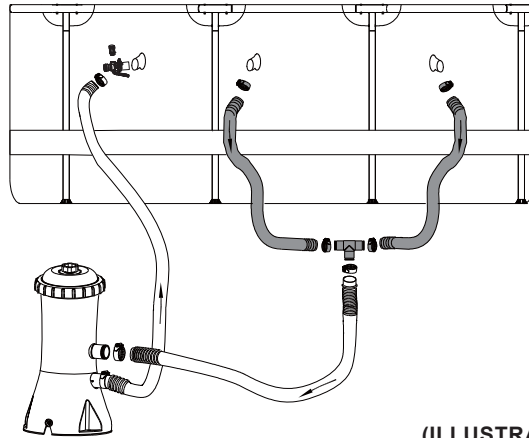

(ILLUSTRATION NOT TO SCALE)

TIMER OPERATION

Connect the filter pump to the power outlet and set the timer dial on the GFCI to the desired operating hours. See the "Operating Time Table" section for the required operating hours related to each pool size. The filter pump is now filtering the water and will stop after the operating hours are completed. The built-in timer will now operate for the number of hours selected at the same time each day.

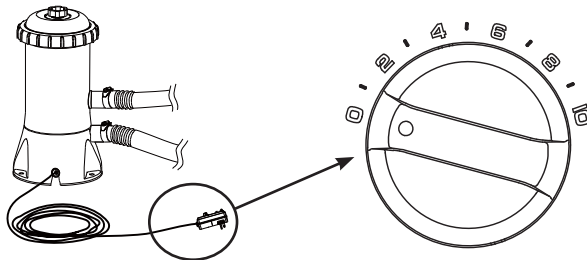

O: OFF
2 / 4 / 6 / 8 / 10: Timer operating time (hours)

⚠ WARNING

Risk of electric shock. Connect this product only to a grounding type receptacle protected by a ground-fault circuit interrupter (GFCI). Contact a qualified electrician if you cannot verify that the receptacle is protected by a GFCI.
Position this product away from the pool, so as to prevent children from climbing on it and accessing the pool.

OPERATING TIME TABLE

This table shows the required operating time for average use of the filter pump with AGP's. The filter pump running time should be 1 hour longer than the required operating time of the Saltwater System. The timer on the GFCI may need to be manually reset in order to extend the pump running time.

| Pool Size | | Water Capacity (Calculated at 90% for Frame Pool and 80% for Easy Set & Oval Pool) | | Recommend operating hours per day (Hours) | |
|--|--|--|----------|---|------------|
| | | (Gals) | (Liters) | Model 603 | Model 637R |
| INTEX ABOVE GROUND POOLS (AGP's) | | | | | |
| SMALL FRAME POOL | 9'10" x 6'6 ³ / ₄ " x 29 ¹ / ₂ " (300cm x 200cm x 75cm) | 1,013 | 3,834 | 4 | - |
| | 14'9 ¹ / ₄ " x 7'2 ⁵ / ₆ " x 33" (450cm x 220cm x 84cm) | 1,883 | 7,127 | 6 | 4 |
| EASY SET® POOL | 10' x 30" (305cm x 76cm) | 1,018 | 3,853 | 4 | - |
| | 12' x 30" (366cm x 76cm) | 1,485 | 5,621 | 4 | - |
| | 13' x 33" (396cm x 84cm) | 1,926 | 7,290 | 6 | 4 |
| | 15' x 33" (457cm x 84cm) | 2,587 | 9,792 | 6 | 4 |
| | 15' x 42" (457cm x 107cm) | 3,284 | 12,430 | - | 6 |
| | 15' x 48" (457cm x 122cm) | 3,736 | 14,141 | - | 6 |
| METAL FRAME POOL | 10' x 30" (305cm x 76cm) | 1,185 | 4,485 | 4 | - |
| | 12' x 30" (366cm x 76cm) | 1,718 | 6,503 | 4 | 4 |
| | 15' x 48" (457cm x 122cm) | 4,440 | 16,805 | - | 8 |
| PRISM FRAME™ PREMIUM POOL | 12' x 30" (366cm x 76cm) | 1,718 | 6,503 | 4 | - |
| | 12' x 39" (366cm x 99cm) | 2,270 | 8,592 | 6 | 4 |
| | 14' x 42" (427cm x 107cm) | 3,357 | 12,706 | 8 | 6 |
| | 15' x 42" (457cm x 107cm) | 3,861 | 14,614 | - | 6 |
| | 15' x 48" (457cm x 122cm) | 4,440 | 16,805 | - | 8 |
| PRISM FRAME™ RECTANGULAR PREMIUM POOL | 13'1 ¹ / ₂ " x 6'6 ³ / ₄ " x 39 ¹ / ₂ " (400cm x 200cm x 100cm) | 1,806 | 6,836 | 6 | - |
| | 13'1 ¹ / ₂ " x 6'6 ³ / ₄ " x 48" (400cm x 200cm x 122cm) | 2,224 | 8,418 | 6 | 4 |
| | 16' x 8' x 42" (488cm x 244cm x 107cm) | 2,873 | 10,874 | 8 | 6 |
| GREYWOOD PRISM FRAME™ PREMIUM POOL | 12' x 30" (366cm x 76cm) | 1,718 | 6,503 | 4 | - |
| | 15' x 48" (457cm x 122cm) | 4,440 | 16,805 | - | 8 |
| PRISM FRAME™ OVAL PREMIUM POOL | 16'6" x 9" x 48" (503cm x 274cm x 122cm) | 3,531 | 13,365 | - | 6 |
| ULTRA XTR™ FRAME POOL | 14' x 42" (427cm x 107cm) | 3,357 | 12,706 | - | 6 |

CLEANING OR REPLACING FILTER CARTRIDGE

1. Make sure filter pump is not operating. Disconnect line cord.
2. To prevent water from escaping the pool, unscrew the pool inlet nozzle (10) and strainer grid (11) from the strainer connectors and insert the hat-like plugs into the strainer connectors.
3. In a counter-clockwise motion, remove the filter housing collar (12) and threaded cover (3). Be careful not to lose the cover seal (4).
4. Remove filter cartridge (5) to clean it. The filter may be cleaned from the spray from a water hose.
5. Use judgement as to whether cartridge needs to be replaced.
6. Return cartridge to filtering position.
7. Return the seal (4) and threaded cover (3) to their original positions and in a clockwise direction rescrew the housing collar (12) onto the filter housing.
8. After service, open the air release valve, remove the plugs, allow any air to escape through the valve before tightening the valve again and replace the pool inlet nozzle (10) and strainer grid (11). The pump is now primed with water again and may be turned on.

POOL CARE AND CHEMICALS

- All pools require care to keep the water clear and hygienically clean. With proper chemical control, your filter will help attain this objective. Consult your pool supply dealer for instructions regarding the proper use of chlorine, algaecide and other chemical agents required for sparkling clear water.
- Keep pool chemicals away from children.
- Do not replenish chemicals in pool while pool is occupied. Skin or eye irritations could occur.
- Daily pH checking and chemical treatment of the water is very important and can not be overemphasized. Chlorine, algaecide and maintenance of proper pH levels are required when filling the pool as well as during the season. Consult your local swimming pool supply store for instructions.
- The season's first filling of the pool may have brackish water requiring extra water additives and extra filter changes. Do not allow swimming in pool until the pH level is balanced. Consult your local swimming pool supply store for instructions.
- Keep spare filter cartridges on hand. Replace cartridges every two weeks.
- Chlorinated water may damage lawns, gardens or shrubbery as children play in the pool and splash water outside the pool. Lawn areas underneath the pool liner will be destroyed. Note that some types of grass may grow through the liner.
- Filter run time depends on pool size, weather and usage level. Experiment with various run times so as to produce clean clear water.

CAUTION

Concentrated chlorine solutions may damage the pool liner. Always follow the chemical manufacturer's directions, and the health and hazard warnings.

LONG TERM STORAGE

1. Before emptying your pool for long term storage, or relocation, be sure the water is directed towards an acceptable drain water receptacle away from the house. Check local regulations for specific directions regarding disposal of swimming pool water.
2. Now, drain the pool.
3. When the pool is empty, disconnect all pool hoses (8) from the pool and filter pump, simply reverse the set up instructions.
4. Remove the filter cartridge as shown in the Filter Cartridge Cleaning section, steps 2 thru 4.
5. Remove the nozzle and strainer unions from the pool wall. Place the wall plugs into the hose connections. Loosen clamps (7) securing the strainer connectors (9) before removal.
6. Drain water from the filter pump housing.
7. Leave filter pump pieces and hoses outside to thoroughly air dry.
8. Depending on the cartridge (5) usage, a new cartridge may be needed for next season, keep a spare available.
9. Cover the seal (4), air release valve O-ring (2) and hose seals (6) with petroleum jelly to preserve its resilience during storage.
10. Store the unit and accessories in a dry place. The storage's temperature should be controlled, between 32 degrees Fahrenheit (0 degrees Celsius) and 104 degrees Fahrenheit (40 degrees Celsius) storage location.
11. The original packing can be used for storage.

TROUBLESHOOTING GUIDE

| TROUBLE | CAUSE | SOLUTION |
|--|--|--|
| FILTER MOTOR FAILS TO START | <ul style="list-style-type: none"> The motor is not plugged in. The GFCI circuit breaker is tripped. Motor too hot and overload protection is shut off. | <ul style="list-style-type: none"> Filter cord must be plugged into a 3 wire outlet that is protected by a Class A Ground Fault Circuit Interrupter. Reset circuit breaker. If circuit breaker trips repeatedly, your electrical system may have a defect. Turn off circuit breaker and call an electrician to correct the problem. Let motor cool down. |
| FILTER DOESN'T CLEAN POOL | <ul style="list-style-type: none"> Improper chlorine or pH levels. Filter cartridge is dirty. Damaged cartridge. Excessively dirty pool. The strainer screen is restricting the water flow. | <ul style="list-style-type: none"> Adjust the chlorine and pH level. Consult your local swimming pool supply stores. Clean or replace cartridge. Check the cartridge for holes. Replace if damaged. Operate the filter for longer periods. Clean the strainer screen at the inlet. |
| FILTER DOESN'T PUMP WATER OR FLOW IS VERY SLOW | <ul style="list-style-type: none"> Clogged inlet or discharge. An air leak on the intake line. Scale or buildup on cartridge. Excessively dirty pool. Dirty filter cartridge. Nozzle and strainer connection are reversed. Pool inlet air adaptor connected to the wrong fitting. | <ul style="list-style-type: none"> Clear any obstructions in the intake hose by discharging it inside pool wall. Tighten hose clamps, check hoses for damage, check pool water level. Replace cartridge. Clean cartridge more often. Install the nozzle at the upper position of the pool inlet, and the strainer at the lower position of the pool outlet. Make sure the pool inlet air adaptor is connected to the pool inlet upper fitting. |
| PUMP DOESN'T WORK | <ul style="list-style-type: none"> Low water level. Strainer screen plugged up. An air leak on the intake hose. Faulty motor or the impeller is jammed. An air lock inside the cartridge chamber. | <ul style="list-style-type: none"> Fill pool to correct water level. Clean strainer screens at pool inlet. Tighten hose clamps, check hose for damage. Clear any sticks or leaves in the intake hose. Open the release valve at top of pump. |
| TOP COVER LEAKING | <ul style="list-style-type: none"> O-ring missing. Cover or air release valve are not tight. | <ul style="list-style-type: none"> Remove cover & check for O-ring. Tighten cover or valve (Manually). |
| HOSE LEAKING | <ul style="list-style-type: none"> Hose clamps are not well-fitted. Hose o-ring dislodged when connecting the hose. Hose broken. | <ul style="list-style-type: none"> Tighten or reinstall hose clamps. Put the o-ring back into the groove. Replace a new hose. |
| AIR LOCK | <ul style="list-style-type: none"> There's air trapped in the pump housing and inlet hose. | <ul style="list-style-type: none"> Open air release valve, lift and lower the inlet hose until water starts to flow out of air release valve, close air release valve. |
| POOL INLET AIR ADAPTOR / AIR JET VALVE LEAKING | <ul style="list-style-type: none"> Hose clamps are not well-fitted. Air jet valve is not tight and facing up. Air jet valve internal seal blocked. Air jet valve internal seal dirty. Air jet valve broken. | <ul style="list-style-type: none"> Tighten or reinstall hose clamps. Tighten air jet valve and make sure it's facing up. Plug in the pump and run for few seconds, then unplug, repeat 3 times. Remove air jet valve, flush dirt out with water and replace valve back. Replace a new air jet valve. |
| SMALL LEAK FROM AIR JET VALVE WHEN PUMP IS ON | <ul style="list-style-type: none"> Accessories attached to the water circulation line. | <ul style="list-style-type: none"> Remove all the accessories (such as solar mat, auto pool cleaner, LED light) from the water circulation line and place the air jet valve cap (13) over the air jet valve (14). Do not cover the air jet valve (14) with the valve cap (13) under normal situation or when the pump is operating. |

COMMON POOL PROBLEMS

| PROBLEM | DESCRIPTION | CAUSE | SOLUTION |
|--------------------------|---|---|---|
| ALGAE | <ul style="list-style-type: none"> Greenish water. Green or black spots on pool liner. Pool liner is slippery and/or has a bad odor. | <ul style="list-style-type: none"> Chlorine and pH levels need adjustment. | <ul style="list-style-type: none"> Super chlorinate with shock treatment. Correct pH to your pool store's recommended level. Vacuum pool bottom. Maintain proper chlorine level. |
| COLORED WATER | <ul style="list-style-type: none"> Water turns blue, brown, or black when first treated with chlorine. | <ul style="list-style-type: none"> Copper, iron or manganese in water being oxidized by the added chlorine. This is common. | <ul style="list-style-type: none"> Adjust pH level to the recommended level. Run filter until water is clear. Clean cartridge frequently. |
| FLOATING MATTER IN WATER | <ul style="list-style-type: none"> Water is cloudy or milky. | <ul style="list-style-type: none"> "Hard water" caused by a too high pH level. Chlorine content is low. Foreign matter in water. | <ul style="list-style-type: none"> Correct the pH level. Check with your pool dealer for advice. Adjust the chlorine level. Clean or replace your filter. |
| CHRONIC LOW WATER LEVEL | <ul style="list-style-type: none"> Level is lower than on previous day. | <ul style="list-style-type: none"> Rip or hole in pool liner or hoses. The drain valves are loose. | <ul style="list-style-type: none"> Repair with a patch kit. Finger tighten all caps. |
| SEDIMENT ON POOL BOTTOM | <ul style="list-style-type: none"> Dirt or sand on pool floor. | <ul style="list-style-type: none"> Heavy use, getting in and out of pool. | <ul style="list-style-type: none"> Use Intex pool vacuum to clean bottom of pool. |
| SURFACE DEBRIS | <ul style="list-style-type: none"> Leaves, insects etc. | <ul style="list-style-type: none"> Pool too close to trees. | <ul style="list-style-type: none"> Use Intex pool skimmer. |

IMPORTANT

If you continue to experience difficulty, please contact our Consumer Service Department for assistance. See separate "Authorized Service Centers" sheet.

GENERAL AQUATIC SAFETY

Water recreation is both fun and therapeutic. However, it involves inherent risks of injury and death. To reduce your risk of injury, read and follow all product, package and package insert warnings and instructions. Remember, however, that product warnings, instructions and safety guidelines cover some common risks of water recreation, but do not cover all risks and dangers.

For additional safeguards, also familiarize yourself with the following general guidelines as well as guidelines provided by nationally recognized Safety Organizations:

- Demand constant supervision. A competent adult should be appointed as a “lifeguard” or water watcher, especially when children are in and around the pool.
- Learn to swim.
- Take the time to learn CPR and first aid.
- Instruct anyone who is supervising pool users about potential pool hazards and about the use of protective devices such as locked doors, barriers, etc.
- Instruct all pool users, including children what to do in case of an emergency.
- Always use common sense and good judgement when enjoying any water activity.
- Supervise, supervise, supervise.

For additional information on safety, please visit

- **The Association of Pool and Spa Professionals: The Sensible Way to Enjoy Your Aboveground/Onground Swimming Pool** www.nspi.org
- **American Academy of Pediatrics: Pool Safety for Children** www.aap.org
- **Red Cross** www.redcross.org
- **Safe Kids** www.safekids.org
- **Home Safety Council: Safety Guide** www.homesafetycouncil.org
- **Toy Industry Association: Toy Safety** www.toy-tia.org

LIMITED WARRANTY

Your Krystal Clear™ Filter Pump has been manufactured using the highest quality materials and workmanship. All Intex products have been inspected and found free of defects prior to leaving the factory. This Limited Warranty applies only to the Krystal Clear™ Filter Pump and accessories listed below.

The provisions of this Limited Warranty apply only to the original purchaser and is not transferable. This Limited Warranty is valid for the period noted below from the date of the initial retail purchase. Keep your original sales receipt with this manual, as proof of purchase will be required and must accompany warranty claims or the Limited Warranty is invalid.

Krystal Clear™ Filter Pump Warranty – 2 Years
Hoses & Fittings Warranty – 180 days

If a manufacturing defect is found within the periods noted above, please contact the appropriate Intex Service Center listed in the separate "Authorized Service Centers" sheet. The Service Center will determine the validity of the claim. If the Service Center directs you to return the product, please carefully package the product and send with shipping and insurance prepaid to the Service Center. Upon receipt of the returned product, the Intex Service Center will inspect the item and determine the validity of the claim. If the provisions of this warranty cover the item, the item will be repaired or replaced at no charge.

Any and all disputes regarding the provisions of this Limited Warranty shall be brought before an informal dispute settlement board and unless and until the provisions of these paragraphs are carried forth, no civil action may be instituted. The methods and procedures of this settlement board shall be subject to the rules and regulations set forth by the Federal Trade Commission (F.T.C.). IMPLIED WARRANTIES ARE LIMITED TO THE TERMS OF THIS WARRANTY AND IN NO EVENT SHALL INTEX, THEIR AUTHORIZED AGENTS OR EMPLOYEES BE LIABLE TO THE BUYER OR ANY OTHER PARTY FOR DIRECT OR CONSEQUENTIAL DAMAGES OR LIABILITIES. Some states, or jurisdictions do not allow the exclusion or limitation of incidental or consequential damages, so the above limitation or exclusion may not apply to you.

This Limited Warranty does not apply if the products are subject to negligence, abnormal use or operation, accident, improper operation, improper voltage or current contrary to operating instructions, or to damage by circumstances beyond Intex's control, including but not limited to, ordinary wear and tear and damage caused by exposure to fire, flood, freezing, rain, or other external environmental forces. This Limited Warranty applies only to those parts and components sold by Intex. The Limited Warranty does not cover unauthorized alterations, repairs or disassembly by anyone other than Intex Service Center personnel.

DO NOT GO BACK TO THE PLACE OF PURCHASE FOR RETURN OR REPLACEMENT. IF YOU ARE MISSING PARTS OR NEED ASSISTANCE, PLEASE CALL US (FOR U.S. AND CANADIAN RESIDENTS): 1-310-549-8235 OR VISIT OUR WEBSITE: WWW.INTEXCORP.COM.

Proof of Purchase must accompany all returns or the warranty claim will be invalid.