

HERITAGE

ABOVE GROUND POOL OVAL INSTALLATION MANUAL

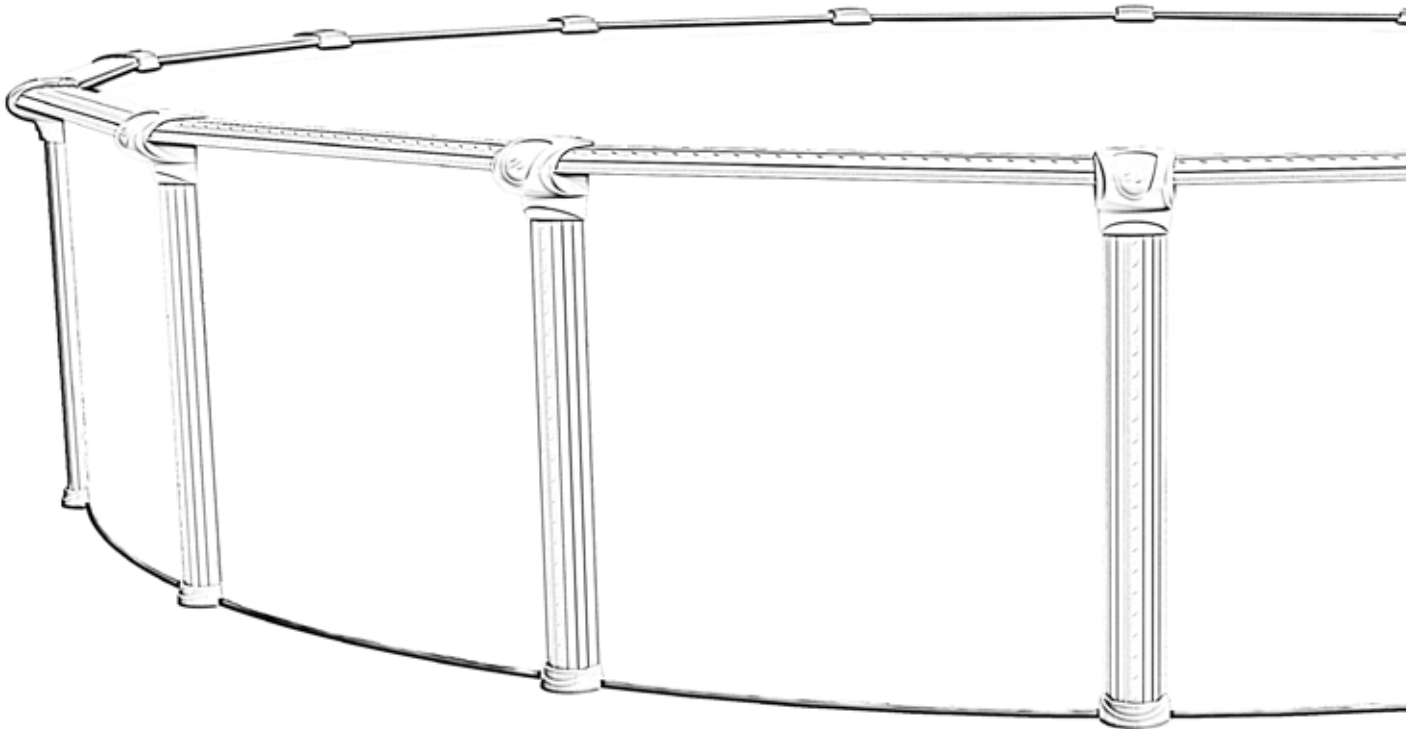

PHER-YM-SSPSRH1

05.2024

ABOVE GROUND POOL SAFETY - PLEASE READ BEFORE INSTALLATION!



WARNING

Carefully read, understand and follow all information in this user manual before installing and using the swimming pool. These warnings, instructions and safety guidelines address some common risks of water recreation, but they cannot cover all risks and dangers in all cases.

Always use caution, common sense and good judgment when enjoying any water activity. **RETAIN THIS INFORMATION FOR FUTURE USE.**

Your pool contains a large quantity of water, and is deep enough to present inherent dangers to life and health unless the following safety rules are strictly observed. First-time users run the highest risk of injury. Make sure everyone understands and encourage all users especially children to learn how to swim. Learn Basic Life Support (Cardiopulmonary Resuscitation-CPR) and refresh this knowledge regularly. Instruct all pool users, including children, what to do in case of an emergency. Keep a working phone and a list of emergency phone numbers near the pool. This can make a life-saving difference in the event of an emergency. To ensure your pool is used safely you **MUST** observe the following safety precautions:

SAFETY RECOMMENDATIONS

Make sure everyone using your swimming pool is aware of these recommendations and follows them.

1. NEVER JUMP AND DIVE. Your above ground pool is not deep enough to safely allow diving or jumping. This can result in concussions, paralysis, drowning and even death.

2. NEVER SWIM ALONE. If something happens to you, no one will be able to help you. Someone should always be available to lend assistance in an emergency.

3. NEVER LEAVE CHILDREN UNATTENDED. Never leave a child alone and unsupervised in or near the pool, not even for one second. There is no substitute for constant adult supervision.

4. NO ROUGH PLAY OR RUNNING NEAR THE POOL. Surfaces can become slippery and hazardous when wet, and can result in falls causing serious injuries.

5. RESTRICT ACCESS TO THE POOL. Do not leave chairs or other furniture beside the pool that could be used by a child to climb up into the pool. Ladders must be removed whenever the pool is unattended. A fence with a lockable gate around the pool or yard is strongly recommended and may be required by law in some jurisdictions. Secure doors and windows, where applicable to prevent unauthorized access to the swimming pool. If you have a deck overlooking the pool, you must have a door with an automatic locking system restricting access to water. Remove all toys from the swimming pool and surrounding area when not in use to avoid attracting children to the pool. Barriers, pool covers, pool alarms or similar safety devices are helpful aids, but they are not substitutes for continuous adult supervision.

6. LIFE SAVING EQUIPMENT. Keep a safety rope 1/4" by 50ft with a flotation buoy with an outside diameter of 15". Have it accessible in a prominent area by your pool. Keep a pole not less than 16 feet (4.88m) long with a blunt or hook end available at poolside in case of emergencies. Weak swimmers and non-swimmers should wear personal protection equipment when using the pool.

7. LIGHT THE POOL AT NIGHT. If the pool is used after dusk, adequate lighting must be provided. Illumination in the pool area must be sufficient to clearly judge pool depth and all features in and around the pool. For lightning recommendations, consult your local licensed electrical contractor.

8. KEEP OFF TOP LEDGES. Do not walk or sit on the top ledges, they can be slippery and result in dangerous falls.

9. NO ALCOHOL OR DRUGS. Never drink alcoholic beverages, use any intoxicants or medication which could hinder your judgment and reflexes.

FAILURE TO HEED THESE WARNINGS CAN RESULT IN PERMANENT INJURY, PARALYSIS FROM A BROKEN NECK, ELECTROCUTION OR DROWNING. THIS POOL IS NOT DESIGNED FOR DIVING OR JUMPING! DANGEROUS INJURY CAN RESULT. SHALLOW WATER!

10. KEEP YOUR POOL CLEAN AND SANITARY. Your filter system will remove suspended particles from the water and the surface skimmer will remove insects, leaves and other debris from the water surface. Use the correct pool chemicals as directed to destroy harmful bacteria and prevent formation of algae. Remember, unsanitary water is a serious health hazard.

11. POOL COVER SAFETY. The cover must have a tamperproof locking retainer cable that positions the cover around the pool wall and keeps it securely in place. Never allow anyone, especially children on the cover. Asphyxiation or drowning could result. Be sure to remove pool cover completely from the water surface before entering the pool. When purchasing any pool cover, please consult a swimming pool professional.

12. POOL CHEMICALS. Store pool chemicals out of the reach of children. Always follow chemical manufacturer's instructions when storing, handling and dispensing pool chemicals.

13. DO NOT USE GLASS BOTTLES OR CONTAINERS in or around the pool. It can cause injuries or damage the pool.

14. ELECTRICAL DAMAGE. Never touch or attempt to service electrical equipment, including the filter when your body and or the ground is wet. Electrocution or permanent injury due to high voltage (120V AC) could result. The pool should be bonded in accordance with Section 680-26 of the National Electrical Code. For further assistance contact your dealer or local licensed electrician. Do not use pool during electrical or rain storms.

15. CHECK FOR DAMAGE. Periodically check your pool and ladder components for damage and wear. Be sure all screws are in place. Replace all damaged or worn components and tighten all screws before you use the pool, deck or ladders. At first sign, remove rust and touch up immediately.

16. POOL PARTS. Never modify the pool or accessories, or remove or drill holes in the pool, deck or ladder components unless instructed. Your pool wall is made of thin metal, there is an inherent cut hazard with metal so use gloves during installation. Always use Original Equipment Manufactured parts for your replacement parts.

FOLLOW ALL SAFETY INSTRUCTIONS

Read and follow all safety instructions packaged with pool, ladder, deck or any other accessory. Additional pool safety publications can be obtained by contacting the Pool and Hot Tub Alliance (www.phta.org).

IMPORTANT

TO OWNERS AND INSTALLERS: The safety stickers must be installed as per the following instructions. Failure to properly install warning labels will void warranty. Failure to mount these safety labels may subject you to substantial liability in case of injury. These warnings are not to be removed under any circumstances! If they become discolored or fall off, please request replacements which will be sent at no charge.

PLACE SIGN ON TOP LEDGE, OPPOSITE ENTRY TO POOL.



PLACE SIGN ON WALL NEXT TO POOL ENTRY.



REMEMBER TO WATCH CHILDREN.





IMPORTANT INFORMATION ABOUT YOUR LINER

We do not make or supply liners for our pools.

Please contact your liner's manufacturer with questions or if instructions are not included with the liner.

Liner must be installed per the liner manufacturer's instructions.

Incorrect liner installation may void the warranty.

PARTS LISTING

HERITAGE OVAL
PHER-YM****52SSPSRH1

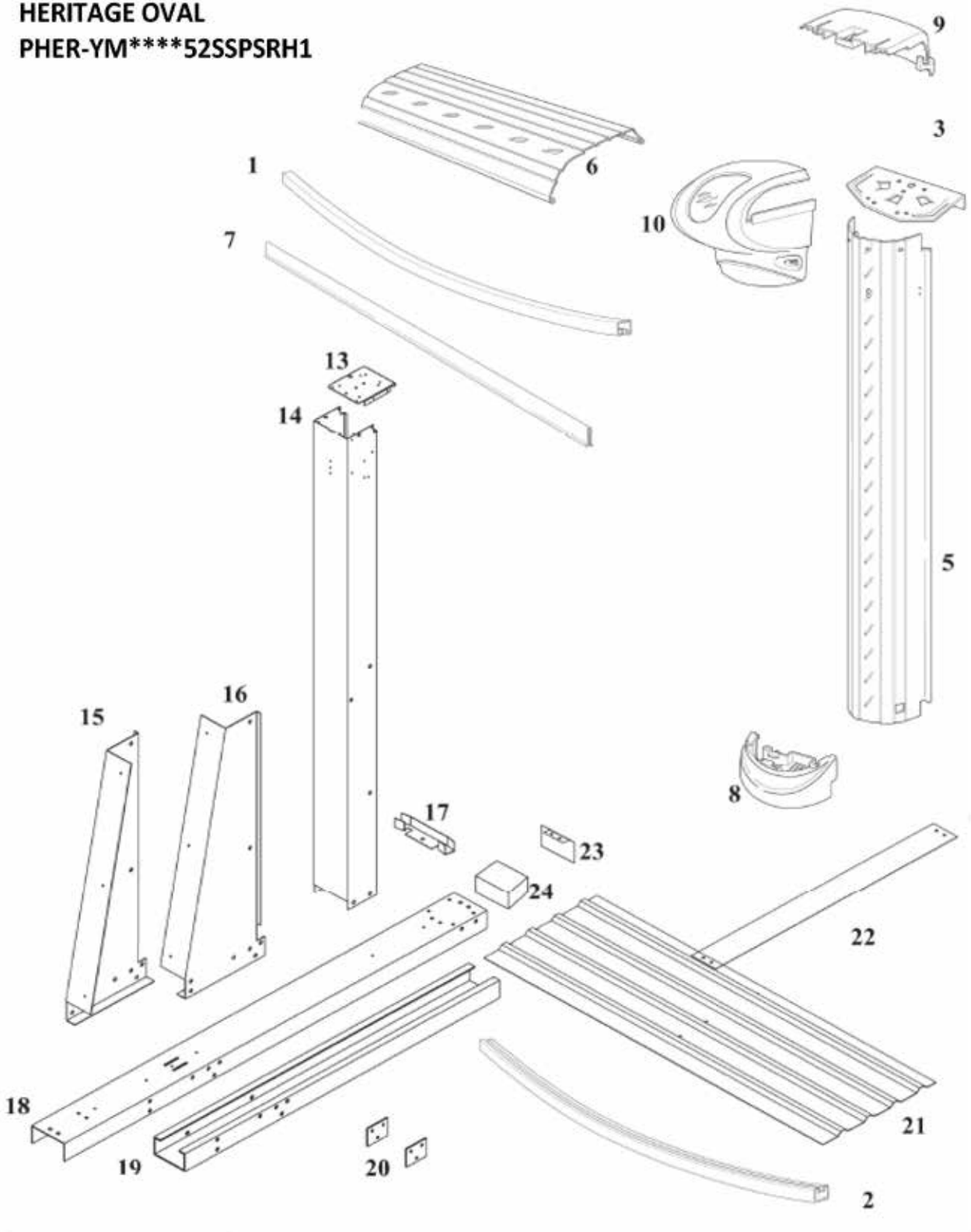

⚠ IMPORTANT NOTE:
Make sure you have all the parts necessary before you start installation.

PARTS LISTING

Product Description:		Heritage Yardmore Oval														
Product Code		PHER-YM****52SSPSRH1														
		Qty Required for Installation (by Size)														
Index #	Description	Part #	Length	812	815	1016	1217	1218	1220	1224	1524	1526	1530	1833	1840	2143
6	Top Rail Curved	22750	40-1/8"			6	12	8	10	10						
6	Top Rail Curved	22751	51-1/6"								10	10	10			
6	Top Rail Curved	22752	51-13/16"											12	12	
6	Top Rail Curved	22755	55-13/16"													14
6	Top Rail Curved	22749	27-1/4"	10	10											
6	Top Rail Transition	38042	45-5/8"			4										
6	Top Rail Transition	29812	47-1/4"					4			4					
6	Top Rail Transition	27944	30"	4	4											
6	Top Rail Straight Side	22756	41-1/4"		2	2	2	2	8	8	2	8	10	10	14	12
5	Upright	22759	51-5/8"	12	12	8	10	10	12	12	12	12	12	14	14	12
14	Wrap Upright	35738	52"	2	4	4	4	4	6	6	4	6	8	8	12	14
9	Top Cap Small Inner	22734	7"	14	16	12	14	14	16	18	16	18	20	22	26	26
10	Top Cap Large Outer Straight	22733	7"	2	4	4	4	4	4	6	4	6	8	8	12	14
10	Top Cap Large Outer Curved	22732	7"	12	12	8	10	10	12	12	12	12	12	14	14	12
8	Top Cap Boot	22735	7"	12	12	8	10	10	12	12	12	12	12	14	14	12
13	Top Plate Oval	22762	6"	2	4	4	4	4	4	6	4	6	8	8	12	14
3	Top Plate	22761	6"	12	12	8	10	10	12	12	12	12	12	14	14	14
7	Plastic Coping	10296	48"	9	11	12	14	14	15	16	19	19	19	21	24	28
1	Inner Stabilizer	38515	29-1/2"	4	4											
1	Inner Stabilizer	38516	41-3/8"			4										
1	Inner Stabilizer	38501	42-5/8"			6	12	8	10	10						
1	Inner Stabilizer	38502	53-1/4"								10	10	10			
1	Inner Stabilizer	38503	54-1/8"											12	12	
1	Inner Stabilizer	38500	29-1/2"	10	10											
1	Inner Stabilizer	38505	54-7/16"													14
1	Rim	22909	39"						4							
1	Wall Rim Center	38513	8"	2	4	4	4	4	4	6	4	6	8	8	12	14
1	Wall Rim Corner	38514	43"					4			4					
1	Wall Rim Corner	38511	37"							4		4	4	4	4	
1	Wall Rim Middle	38512	33"		2	2	2	2	2	4	2	4	6	6	10	12
2	Bottom Rail	38736	38"			6	12	8		10						
2	Bottom Rail	10289	38"						10							
2	Bottom Rail	14950	49"								10	10	10			
2	Bottom Rail	14949	50"											12	12	
2	Bottom Rail	18837	25-1/4"	10	10											
2	Bottom Rail Transition	37391	27-1/4"	4	4											
2	Bottom Rail Straight Side	16713	37.5"		2	2	2	2		4	2	4	6	6	10	12
2	Bottom Rail Straight Side	16543	37-1/2"						2							
2	Bottom Rail Straight Side	38739	54-5/16"													10
2	Bottom Rail Corner	38035	42-5/8"			4										
2	Bottom Rail Corner	22901	45"					4			4					
2	Bottom Rail Corner	16544	39"						4							
2	Bottom Rail Corner	16714	39"							4		4	4	4	4	
2	Bottom Rail Corner	26097	54-5/16"													4
17	Connector Bottom Rail Straight Side	16542	1"	2	4	4	4	4	6	6	4	6	8	8	12	14
21	Pressure Plate	16549	44"	4	4	4	4	4	6	6	4	6	8	8	12	14
23	Oval Channel End Cap	22726		2	4	4	4	4	6	6	4	6	8	8	12	14
24	Oval Channel Foam Block	29917	2x4x4-1/8"	2	4	4	4	4	6	6	4	6	8	8	12	14
19	Under Channel	15933	45-9/16"	2	4	4	4	4	6	6	4	6	8	8	12	14
15	Yardmore Gusset Left	35740		2	4	4	4	4	6	6	4	6	8	8	12	14
16	Yardmore Gusset Right	35741		2	4	4	4	4	6	6	4	6	8	8	12	14
18	Strap Over Channel	16539	52-3/8"	2	4	4	4	4	6	6	4	6	8	8	12	14
22	Strap Section	33095	28-5/8"			8										
22	Strap Section	16723	39-9/32"			2										
22	Strap Section	16724	41-11/16"				4	4	6	6						
22	Strap Section	16725	40-11/16"								6	9	12			
22	Strap Section	16726	52-11/16"											12	18	
22	Strap Section	33160	32-1/4"		2											
23	Strap Section	22126	48.984"													28
20	Hardware Yardmore (4 Upright)	22-16720			1	1	1	1	1	1	1	1	2	2	3	3
20	Hardware Yardmore (2 Upright)	22-16722		1					1	1	1	1				1
*	Hardware	44-10019		1		1										
*	Hardware	44-10020			1				1							
*	Hardware	44-10212		1												
*	Hardware	44-10022					1	1								
*	Hardware	44-10025									1					
*	Hardware	44-10023								1						
*	Hardware	44-10024									1					
*	Hardware	44-10026											1			
*	Hardware	44-10027												1		
*	Hardware	44-10028													1	
*	Hardware	44-10029														1
*	Instruction Addendum for SSS Oval	95-0701			1											
*	Envelope Safety Stickers	95-0007		1	1	1	1	1	1	1	1	1	1	1	1	1

*May not be pictured

PARTS LISTING

HERITAGE OVAL
PHER-YM****54SSPSRH1

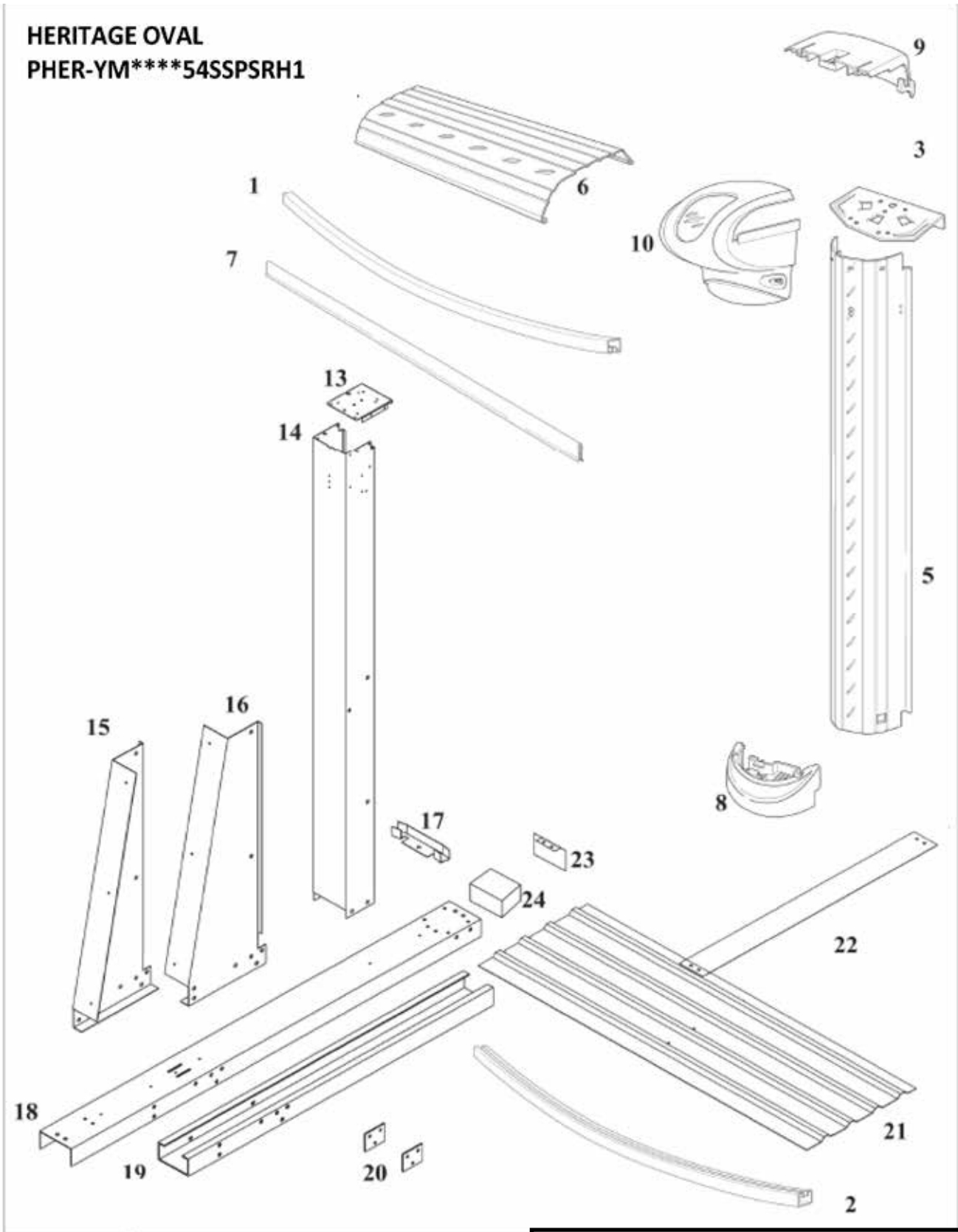

⚠ IMPORTANT NOTE:
Make sure you have all the parts necessary before you start installation.

PARTS LISTING

Product Description:		Heritage Yardmore Oval								
Product Code:		PHER-YM****54SSPSRH1								
Quantity Required for Installation (by Pool Size)										
Index #	Description	Part #	Length	1217	1224	1524	1526	1530	1833	1840
6	Top Rail Curved	22750	40-1/8"	12	10					
6	Top Rail Curved	22751	51-3/16"			10	10	10		
6	Top Rail Curved	22752	51-15/16"						12	12
6	Top Rail Transition	29812	47-1/4"			4				
6	Top Rail Straight Side	22756	41-1/4"	2	8	2	8	10	10	14
14	Wrap Upright	35739	54"	4	6	4	6	8	8	12
5	Upright	22760	53-5/8"	10	12	12	12	12	14	14
9	Top Cap Small Inner Half	22734	7"	14	18	16	18	20	22	26
10	Top Cap Large Outer Half Straight Side	22733	7"	4	6	4	6	8	8	12
10	Top Cap Large Outer Half Curved Side	22732	7"	10	12	12	12	12	14	14
8	Top Cap Boot	22735	7"	10	12	12	12	12	14	14
3	Top Plate	22761	6"	10	12	12	12	12	14	14
3	Top Plate Oval	22762	6"	4	6	4	6	8	8	12
7	Plastic Coping	10296	48"	14	16	19	19	19	21	24
23	Oval Channel End Cap	22726		4	6	4	6	8	8	12
24	Oval Channel Foam Block	29917	2x4x4-1/8"	4	6	4	6	8	8	12
1	Rim	38513	8"	4	6	4	6	8	8	12
1	Rim	38512	33"	2	4	2	4	6	6	10
1	Rim	38511	37"		4		4	4	4	4
1	Rim	38514	43"			4				
1	Inner Stabilizer	38501	42-5/8"	12	10					
1	Inner Stabilizer	38502	53-1/4"			10	10	10		
1	Inner Stabilizer	38503	54-1/8"						12	12
2	Bottom Rail	38736	38"	12	10					
2	Bottom Rail	14950	49"			10	10	10		
2	Bottom Rail	14949	50"						12	12
2	Bottom Rail Straight Side	16713	37-1/2"	2	4	2	4	6	6	10
2	Bottom Rail Corner	16714	39"		4		4	4	4	4
2	Bottom Rail Corner	22901	45"			4				
17	Connector Bottom Rail Straight Side	16542	1"	4	6	4	6	8	8	12
21	Pressure Plate	16549	44"	4	6	4	6	8	8	12
18	Strap Over Channel	16539	52-3/8"	4	6	4	6	8	8	12
19	Under Ground Channel YM	15933	45-9/16"	4	6	4	6	8	8	12
15	Yardmore Gusset Left	35740		4	6	4	6	8	8	12
16	Yardmore Gusset Right	35741		4	6	4	6	8	8	12
22	Strap Section	16724	41-11/16"		6					
22	Strap Section	16725	40-11/16"			6	9	12		
22	Strap Section	16726	52-11/16"						12	14
23	Strap Section	16723	39-9/32"							2
20	Hardware Stainless Steel YM 4 Upright	22-16720		1	1	1	1	2	2	3
20	Hardware Stainless Steel YM 2 Upright	22-16722			1		1			
*	Hardware	44-10022		1						
*	Hardware	44-10023			1					
*	Hardware	44-10024				1				
*	Hardware	44-10025					1			
*	Hardware	44-10026						1		
*	Hardware	44-10027							1	
*	Hardware	44-10028								1
*	Envelope Safety Stickers	95-0007		1	1	1	1	1	1	1

*May not be pictured

INTRODUCTION:

Congratulations on becoming the owner of a new above ground swimming pool. This is the instruction packet for installing your swimming pool. The following are some helpful hints that you should take into consideration before installing your pool.

- 1) Read through the entire instruction booklet before you begin. This will enable you to find out exactly what is involved with installing your swimming pool before you begin. While you are going through the instructions, please be aware that all of the diagrams are representative of a 15' x 30'/18' x 33' pool. If you have a different size pool you will find that your pool has a different number of uprights than the ones in the diagrams.
- 2) **DO NOT ATTEMPT INSTALLATION IN WINDY OR GUSTY WEATHER** This will not only make installation more difficult, it may result in damage to your pool before it is completely installed.
- 3) Although we have broken down the installation into many simple steps, you will probably find that Steps 1 and 2 will be the most labor intensive and time consuming steps. Once you have completed those two steps you should find that the rest of the installation moves along much more quickly.
- 4) Please be sure to review all safety material and local codes before beginning your installation. There is a yellow safety envelope packed with your pool. This envelope contains safety material and warning stickers to be placed on your pool. If you are missing any of these items please contact your dealer or the factory to obtain it. The warranty is void if all safety precautions are not followed.
- 5) In the event that you need to make a warranty claim, it is important to know the size and model of your swimming pool in order to expedite the handling of your claim. Please fill in the information below and keep for your records. All of this information can be found on the labels attached to the cartons your pool is packed in.

NAME OF POOL: _____

SIZE OF POOL: _____

DATE OF PURCHASE: _____

NAME OF POOLWALL: _____

NAME OF LINER: _____

- 6) Make sure you have the necessary tools and materials before beginning your installation. Below is a list of the tools and materials needed.

- | | |
|-----------------------------|--|
| - Shovel | - Carpenters level and/or transit (Optional) |
| - Tape measure | - Patio Blocks (2" x 8" x 16") |
| - Phillips head screwdriver | - Box cutter (Razor blade) |
| - Duct tape | - Tamp |
| - Sand | - 5/16" wrench |
| - Filter | - 1/4" wrench |
| - Skimmer/Return fitting | |

BUTTRESS-FREE POOL SIZES

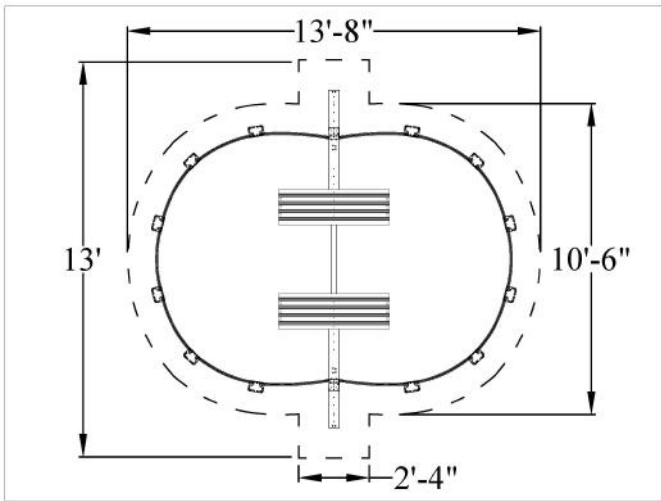

8 x 12

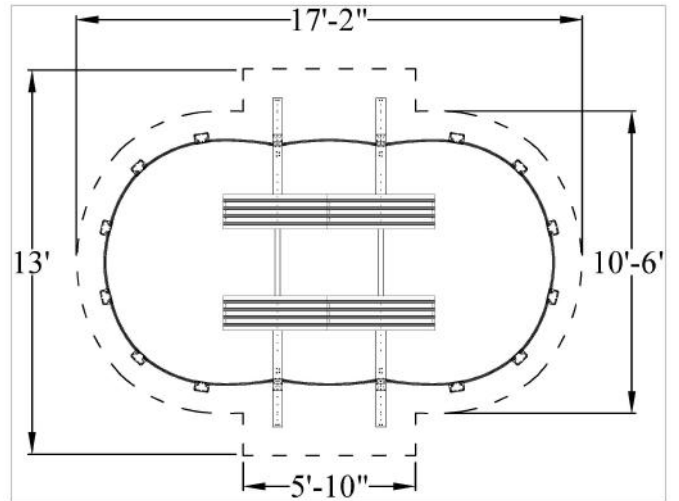

8 x 15

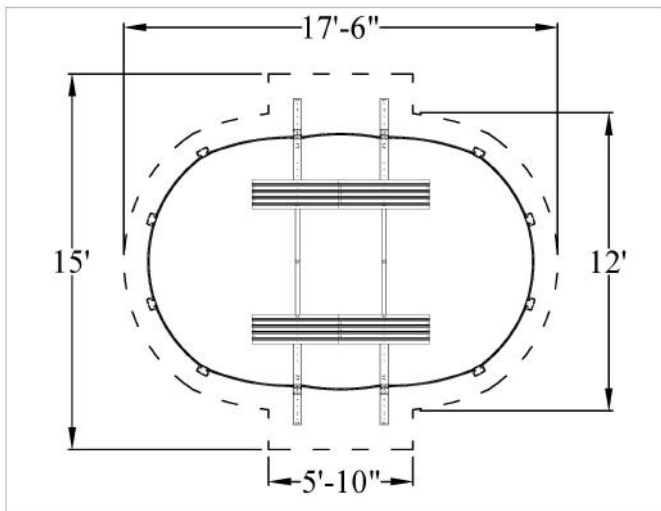

10 x 16

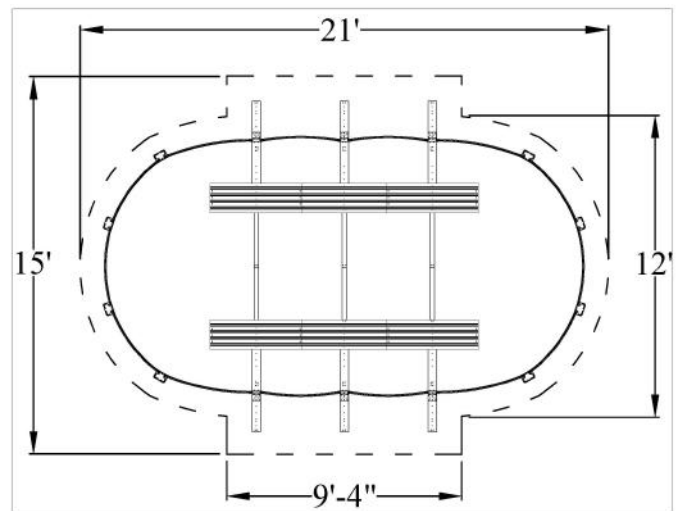

10 x 19

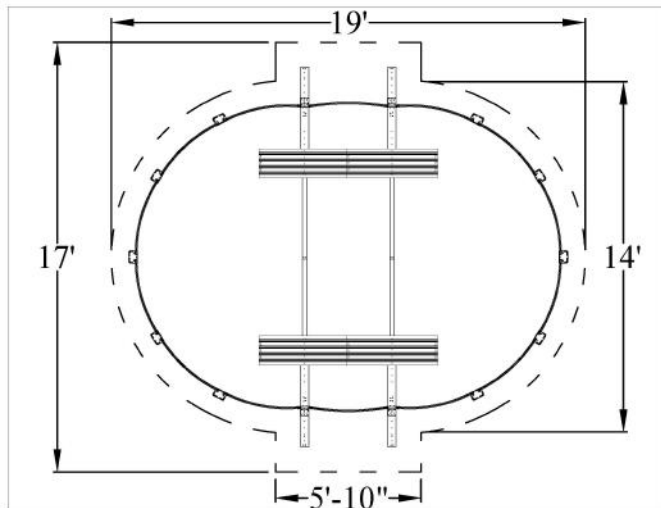

12 x 17

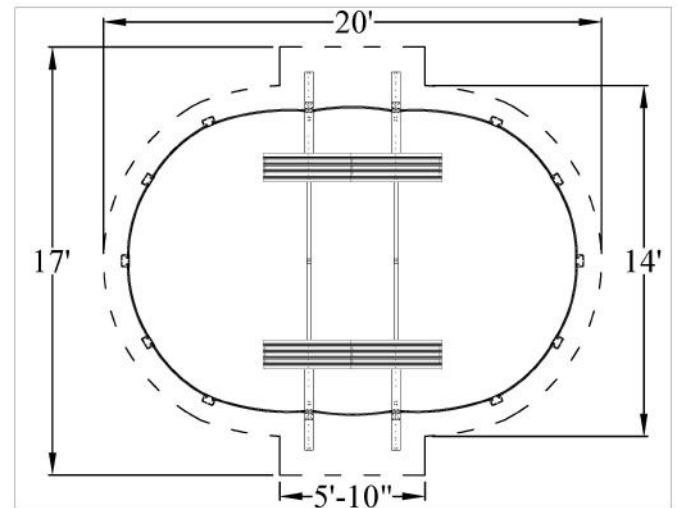

12 x 18

Note: All above diagrams are for Buttness-Free oval pools. If you have a traditional Buttness oval pool, you will need to add 3 feet to the width of the space needed for installation. The length measurement will not change.

- Actual size of pool.
- - - - Space needed for installation.

BUTTRESS-FREE POOL SIZES

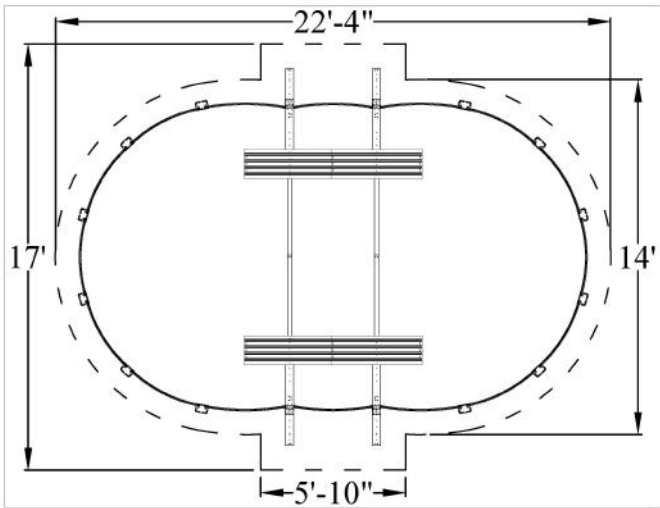

12 x 20

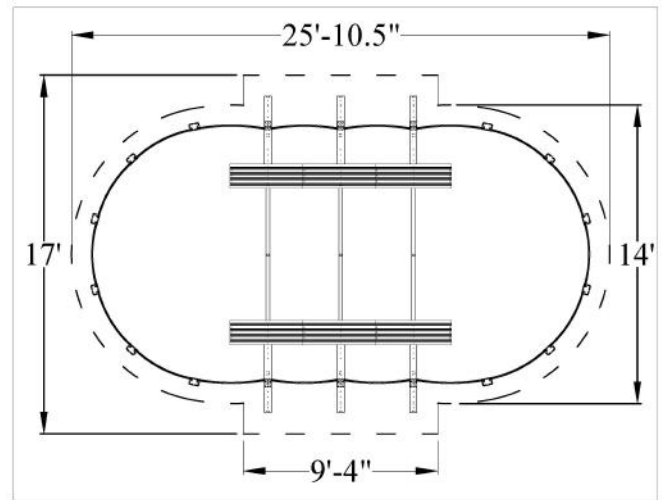

12 x 24

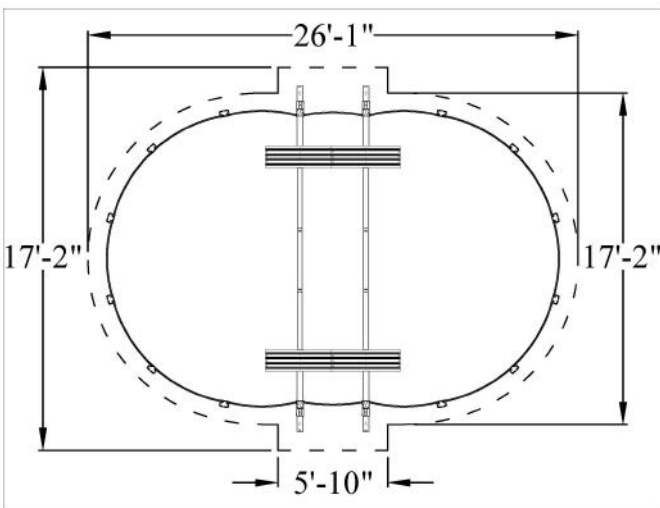

15 x 24

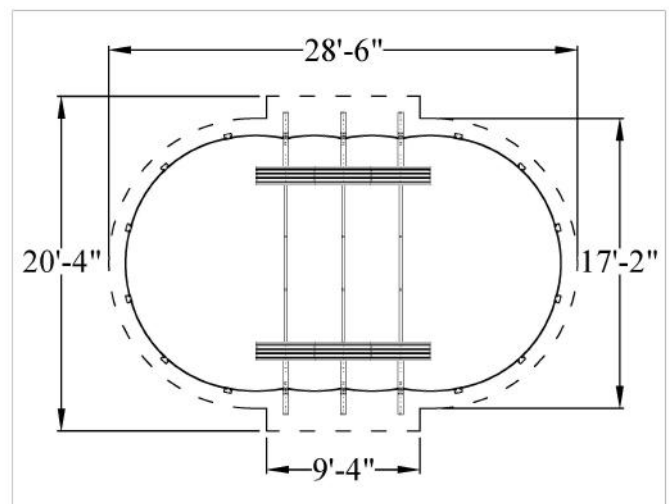

15 x 26

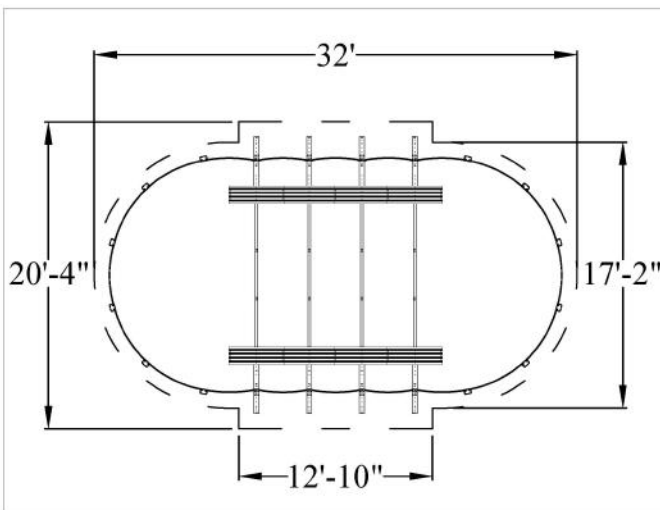

15 x 30

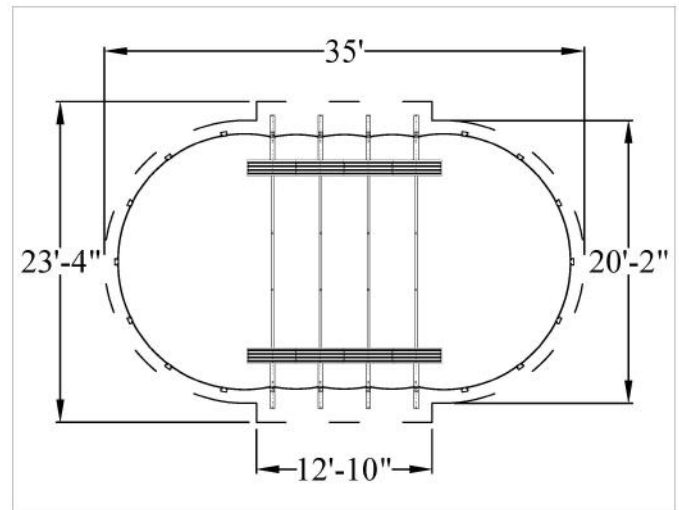

18 x 33

Note: All above diagrams are for Buttness-Free oval pools. If you have a traditional Buttness oval pool, you will need to add 3 feet to the width of the space needed for installation. The length measurement will not change.

- Actual size of pool.
- - - - Space needed for installation.

BUTTRESS-FREE POOL SIZES

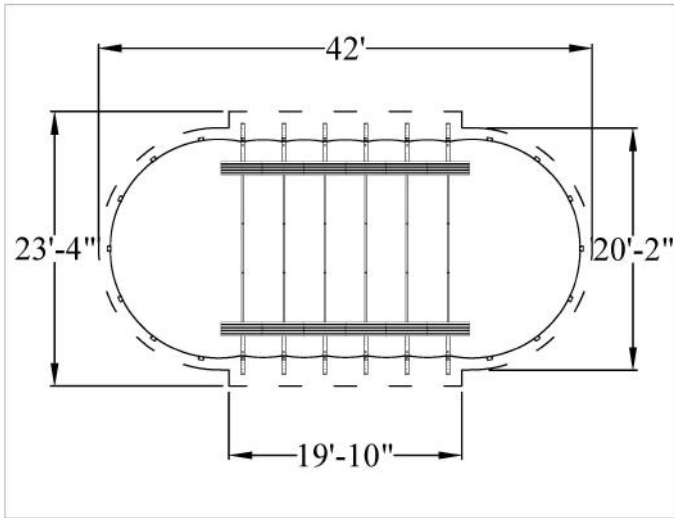

18 x 40

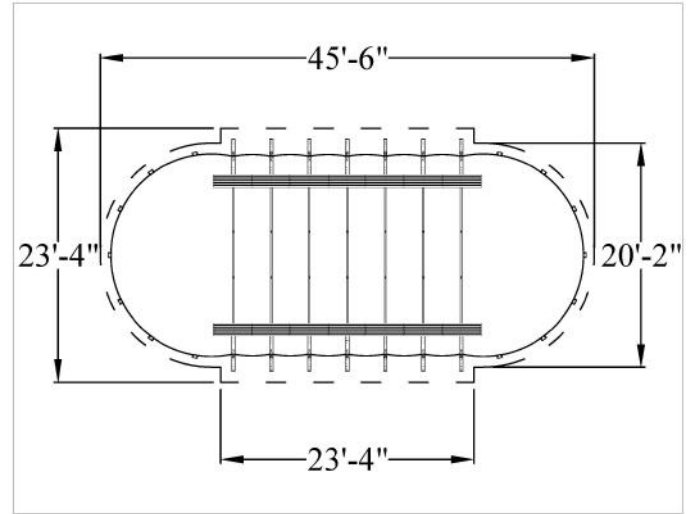

18 x 44

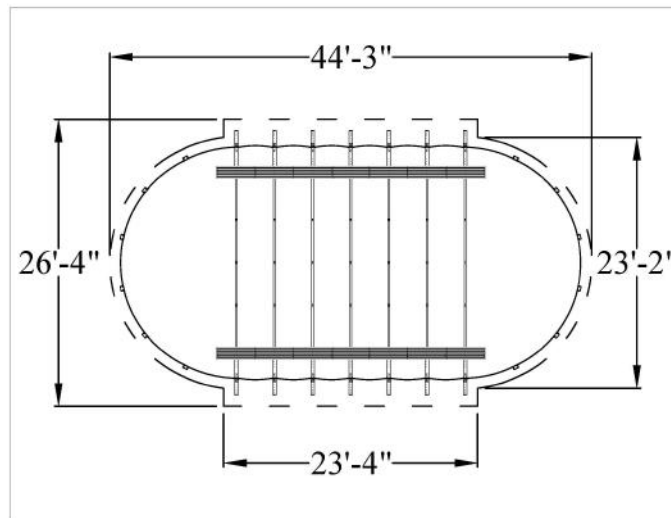

21 x 43

Note: All above diagrams are for Butters-Free oval pools. If you have a traditional Butters oval pool, you will need to add 3 feet to the width of the space needed for installation. The length measurement will not change.

- Actual size of pool.
- - - - Space needed for installation.

POOL LOCATION:

Do not locate pool over underground lines, septic tanks, under electrical lines, near hazardous structures, or out of local code restrictions. It is essential that the area selected for your pool has a level and firm base. Do not assemble your pool on asphalt, tar or oil base surfaces. Avoid areas with sharp objects, or ground treated with weed killer or other chemicals. Also avoid areas where nut grass, Bermuda grass or bamboo grass grows, as they can grow through your liner. Grass must be removed. Refrain from finishing up your pool with stones, rocks, gravel, etc, to avoid chipping of the paint and damaging the pool wall. Most decorative rocks are very acidic and they can damage/corrode your pool wall beyond repair. Do not place components such as filters, pumps, and heaters in a way that they can be used as a means of access to pool by young children. Be sure to follow all local building codes and obtain all building permits required for your area (Fig.1).

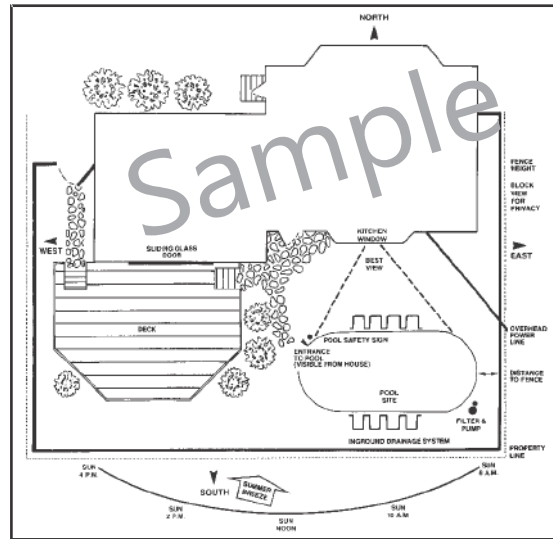

Fig. 1

- *BE SURE TO AVOID:
- All electrical wires
 - All gas lines
 - Septic tanks
 - Cesspools
 - Dry wells
 - Tree roots/ stumps
 - buried debris(trees, building material, etc.)
 - sudden slopes within 6' of pool area

STEP 1 - PREPARING THE SITE:

Refer to the "True Size" diagram on the second page to see the dimensions of your swimming pool. Once you have these measurements and have chosen a site to install your pool, mark or outline the ground where the pool will be going using spray paint or some other marking agent. Please keep in mind that you will need some extra room to work. Be sure to account for the space that the side supports extend out on each side of a n oval pool. The strap end channel extends out 37" from the wall of the pool on each of the two straight sides of a Traditional Buttress Oval (Fig.2). If you have a Buttress-Free Oval Pool, the strap end channel extends only 19" out from the wall on each side (Fig.2A). Refer to the "Actual Size" chart for further clarification.

For example, a 15'x30' oval should have the following space in order to install the pool.

Traditional Buttress Oval:

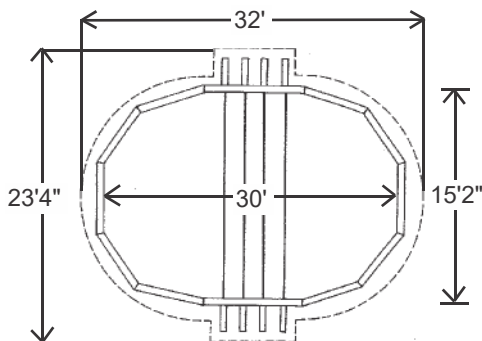

Fig. 2

15 x 30

Buttress-Free Oval:

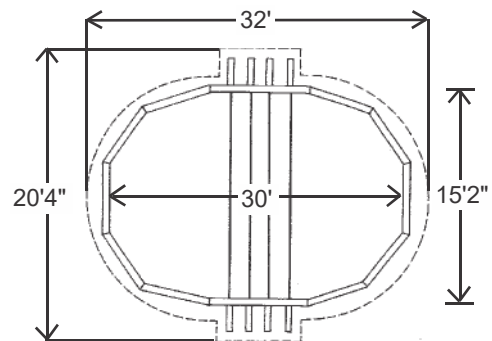

Fig. 2A

15 x 30

*Once you have the appropriate area marked out, remove any sod that is in the area. Also be sure to avoid all electrical wires, gas lines, septic tanks, cesspools, dry wells, tree roots, stumps, buried debris, and sudden slopes within 6' of the pool area.

STEP 2 – LEVELING:

Once you have designated the space for installation, and have cleared away the sod in that area, you can begin to level the ground. The ideal tool for doing this is a transit. If you do not have access to a transit, use a long board (be sure that the board is perfectly straight) and a carpenter's level, as shown in Fig. 4. The key to properly leveling the surface for an above ground swimming pool is to start at the lowest point and dig everything else down to that level. You do not want to build up the lower areas to be level with the higher areas. (Fig.3). Doing this will cause the ground to settle once the pool is full of water. If the ground settles it could destroy your pool, which could be dangerous and is not covered under the warranty.

You will probably not be able to get the ground completely level until you lay out the frame, but the closer you get it now the easier the job will be later. We recommend that you do not proceed until the entire site is within an inch of being perfectly level (Fig.4).

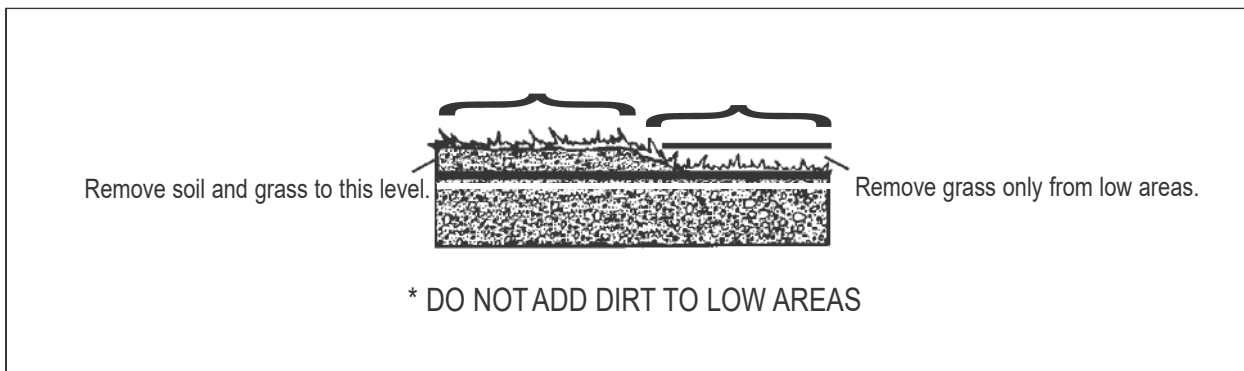

Fig. 3

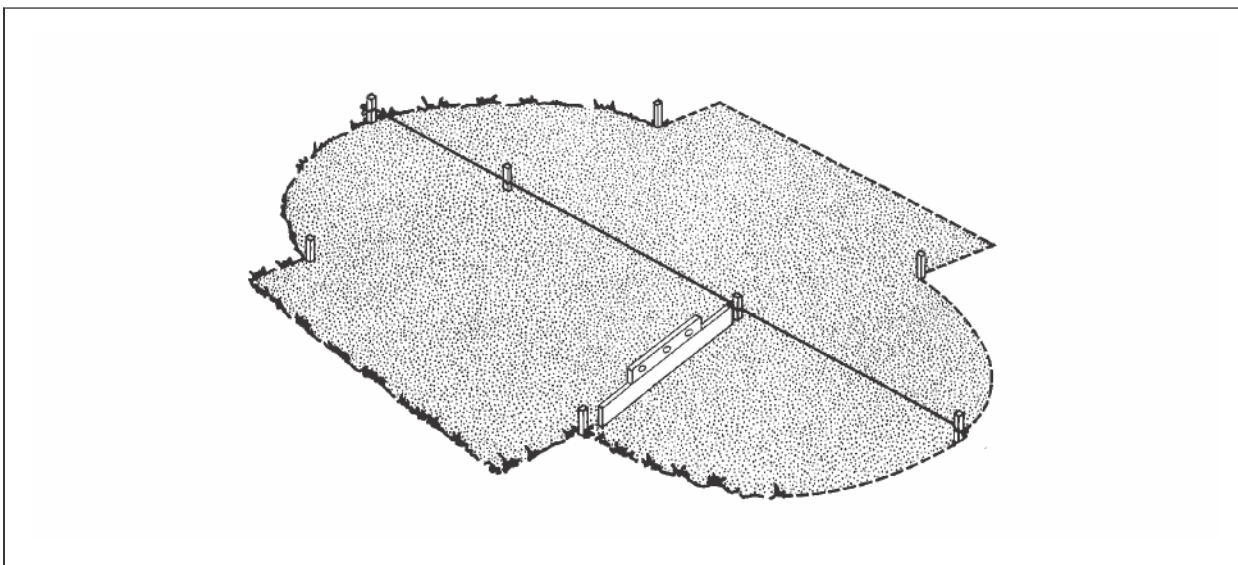

Fig. 4

STEP3 – UNPACKING THE POOL:

At this point you should open all of the cartons that have come with your pool. Separate all of the parts, becoming familiar with each by checking them against the specific parts breakdown sheet. Count the number of each part and check that against the packing list as well. This way if you are missing something you can contact the people you purchased the pool from before you begin the construction of the pool.

Below are some generic diagrams of oval pool components to help you identify the parts and where they will be used. **IMPORTANT: Do not attempt to assemble these parts now. Once you confirm that you have all of the components needed for your pool, continue on with the instructions.**

TRADITIONAL BUTTRESS OVAL ASSEMBLY

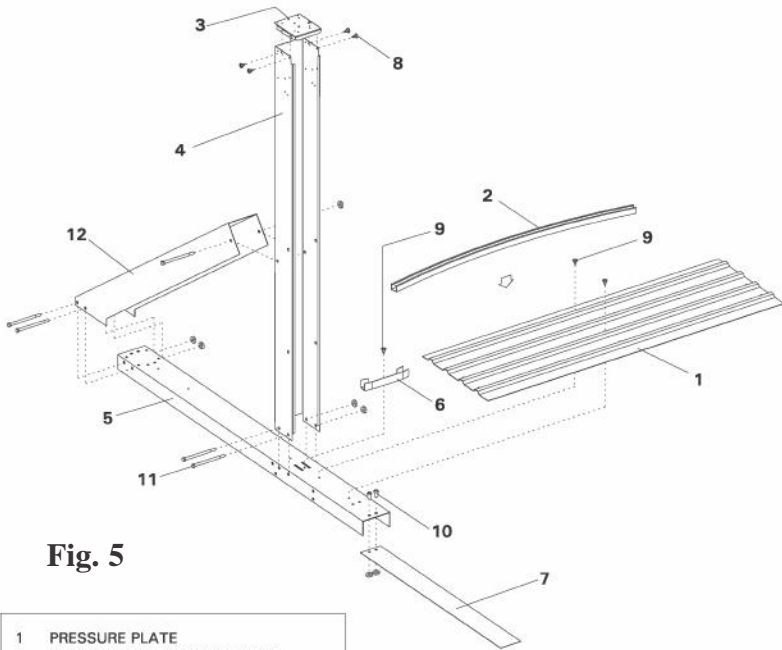

Fig. 5

- 1 PRESSURE PLATE
- 2 BOTTOM RAIL, STRAIGHT SIDE
- 3 STRAIGHT SIDE TOP PLATE
- 4 STRAIGHT SIDE 4"x4" UPRIGHT
- 5 CHANNEL, 2" TALL
- 6 STRAIGHT SIDE BOTTOM CONNECTOR
- 7 STRAP
- 8 SCREWS, #10 X 1/2"
- 9 SCREWS, #12 X 3/4"
- 10 BOLTS, 5/16-18 X 1/2"
- 11 BOLTS, 5/16-18 X 5"
- 12 TRADITIONAL BUTTRESS STRUT

BUTTRESS-FREE OVAL ASSEMBLY:

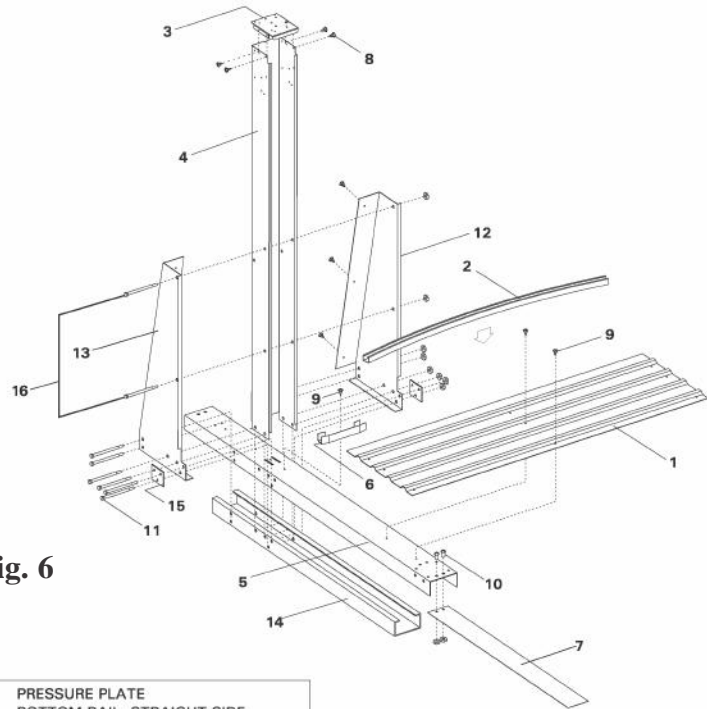
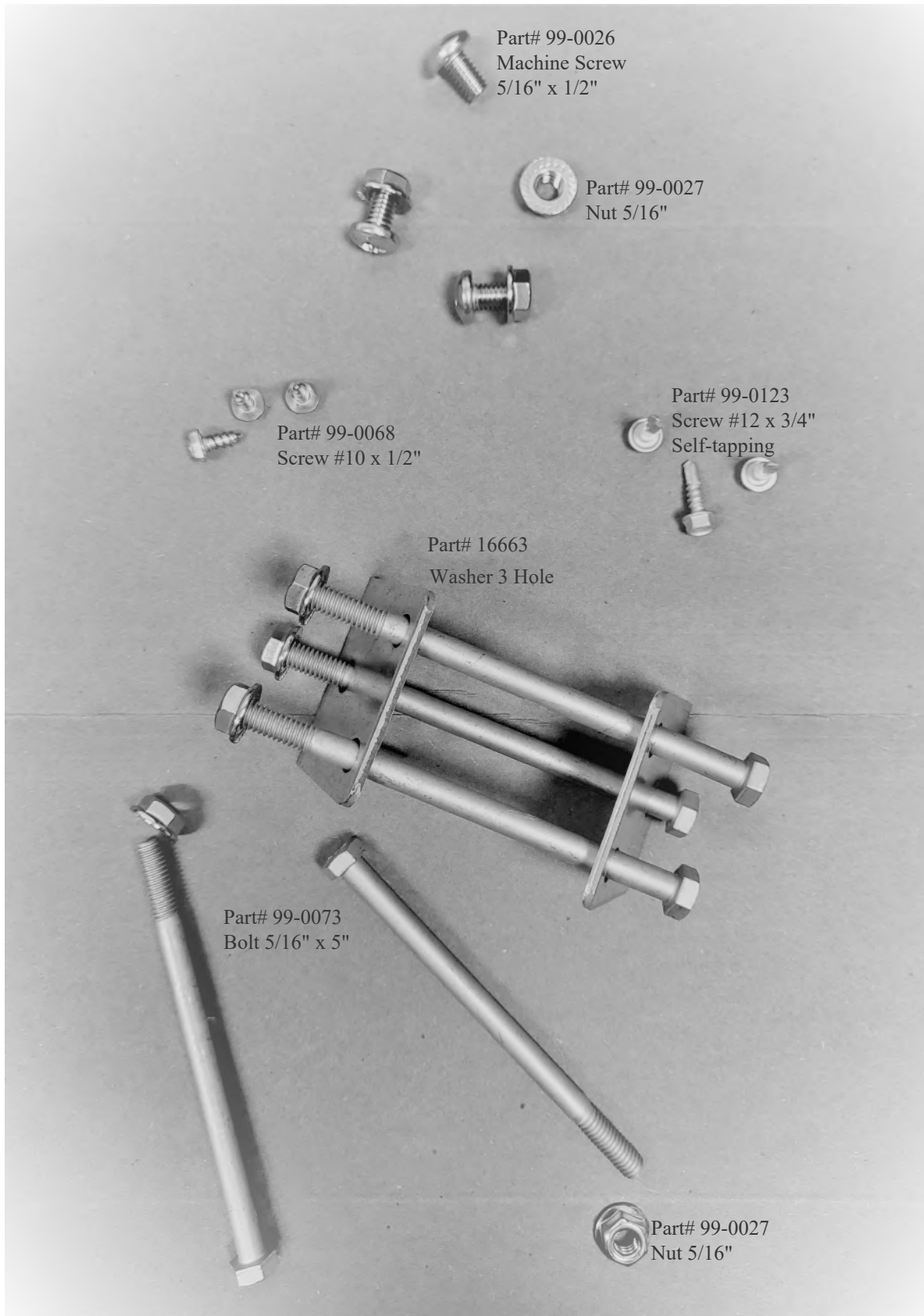

Fig. 6

- 1 PRESSURE PLATE
- 2 BOTTOM RAIL, STRAIGHT SIDE
- 3 STRAIGHT SIDE TOP PLATE
- 4 STRAIGHT SIDE 4"x4" UPRIGHT
- 5 CHANNEL, 2" TALL
- 6 STRAIGHT SIDE BOTTOM CONNECTOR
- 7 STRAP
- 8 SCREWS, #10 X 1/2"
- 9 SCREWS, #12 X 3/4"
- 10 BOLTS, 5/16-18 X 1/2"
- 11 BOLTS, 5/16-18 X 5"
- 12 GUSSET, LEFT SIDE (Buttress-Free)
- 13 GUSSET, RIGHT SIDE (Buttress-Free)
- 14 UNDER BOX CHANNEL
- 15 WASHER, 3 HOLE
- 16 BOLTS, 5/16-18 X 5"

STEP3 – UNPACKING THE POOL - STRAIGHT SIDE HARDWARE:

This page shows the hardware used to assemble the straight section of the oval pool. The hardware used is the same for the traditional Buttress Oval System and for the Buttress-free Oval System but the quantities are different per oval system and pool size.



STEP 4 - PRE-ASSEMBLING THE STRAIGHT SIDES OF A TRADITIONAL BUTTRESS OVAL POOL ONLY:

***** USE THIS STEP FOR TRADITIONAL BUTTRESS OVAL INSTALLATION ONLY! IF YOU HAVE A BUTTRESS-FREE OVAL, GO TO ALTERNATE STEP 4.**

A) Start by laying the strap end channels out on the ground so that the open ends face down. Notice the two slots on top of each of these channels. You will not be using these slots in the construction of the pool, but pay attention to where they are located in the diagrams. They indicate which way the channels are facing. (Fig.7)

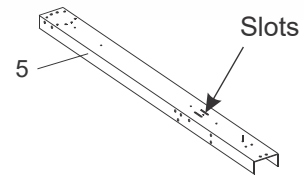

Fig. 7

B) Now take the straight side 4"x4" Upright and push it down over the strap end channel where those slots are located. Position the open end of the straight side upright to face the short end of the channel (the inside of the pool) as shown in Fig.8. The two holes on each side of the upright should line up with two of the holes on each side of the strap end channel. Secure the parts with two 5/16" x 5" bolts and two 5/16" nuts. Repeat for all assemblies.

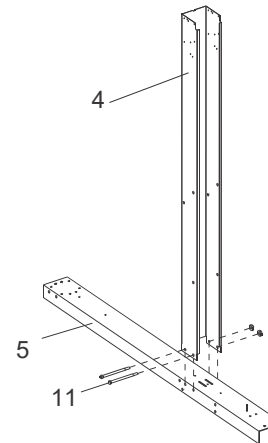

Fig. 8

C) Once all of the straight side uprights are attached, you can begin attaching the struts. This is done by pushing the angled end of the strut (the end with two holes on each side) over the end of the strap end channel and the other side around the straight side upright. The hole on each side of the strut lines up with the hole in the straight side upright that is farthest from the open end of the straight side upright. The two holes on the other end of the strut line up with the only two holes in the back end of the strap end channel. Secure the struts using three 5/16" x 5" bolts and three 5/16" nuts. (Fig.9).

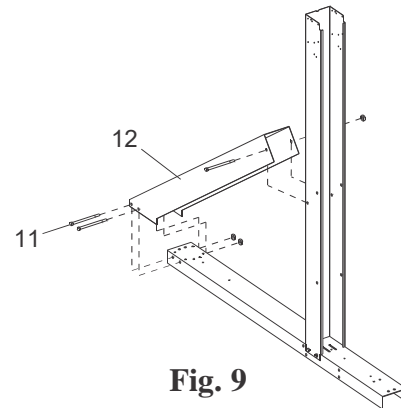

Fig. 9

D) Now you can install the straight side bottom rail connectors. Use one per strap end channel. Place the connector on top of the strap end channel so that the open part of the connector sits inside the straight side upright. The hole in the straight side connector will line up with the hole between the two slots on the strap end channel. (Fig.10). Secure the piece using a #12 x 3/4" self-tapping screw.

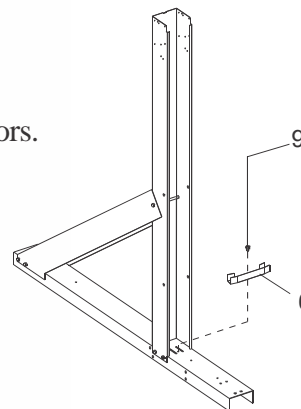

Fig. 10

PART IDENTIFIER

1	PRESSURE PLATE
2	BOTTOM RAIL, STRAIGHT SIDE
3	STRAIGHT SIDE TOP PLATE
4	STRAIGHT SIDE 4"x4" UPRIGHT
5	CHANNEL, 2" TALL
6	STRAIGHT SIDE BOTTOM CONNECTOR
7	STRAP
8	SCREWS, #10 X 1/2"
9	SCREWS, #12 X 3/4"
10	BOLTS, 5/16-18 X 5"
11	BOLTS, 5/16-18 X 5"
12	TRADITIONAL BUTTRESS STRUT

*Please do not be alarmed if you are not using all of the holes in the strap end channels. We use this same channel for a few different products so there are some holes that you will not be using for this pool.

Please follow diagrams to be sure you are using all of the correct holes.

ALTERNATE STEP 4 -

PRE-ASSEMBLING THE STRAIGHT SIDES OF A BUTTRESS-FREE OVAL POOL ONLY:

***THIS ALTERNATE STEP IS FOR BUTTRESS FREE OVAL INSTALLATION ONLY. IF YOU HAVE A TRADITIONAL BUTTRESS OVAL, GO TO BACK TO STEP 4.

A) Start by laying out the under box channels so that the open sides of each under box channel is facing up. This part is 45-9/16" in length. Then slide the strap end channel over the top of the under box channels so that they form a tube. The strap end channel 52-3/8". Be sure that the holes in both channels are aligned, but do not bolt them together yet. (Fig.11)

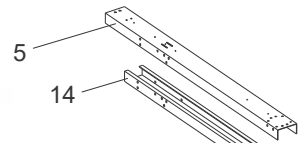

Fig. 11

B) Now slide the straight side 4"x4" uprights over the strap end channels making sure that the holes line up as shown in Fig.12.

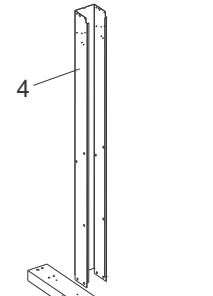

Fig. 12

C) Once the straight side 4"x4" uprights are attached, apply the left and right side gussets on each. The pieces are marked "L" and "R". The gussets are applied under the channels and around the straight side upright. Once you have them in place screw the left and right gussets to each other using three #10 screws. (Fig.13).

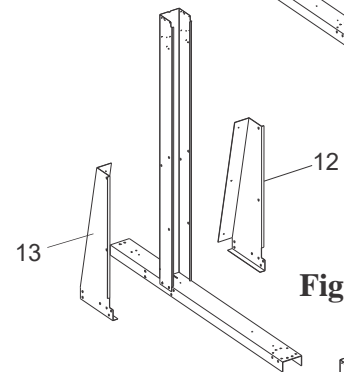

Fig. 13

D) All holes should be lined up at this point. Bolt the components together as shown in the diagram. Use 5/16" x 5" long bolts and 5/16" nuts for the channels, and 5/16" x 5" long steel bolts for connecting the gussets to the uprights. Remember to include the three-hole washer at the fronts of the gussets. If these washers are left off your pool will break! (Fig.14).

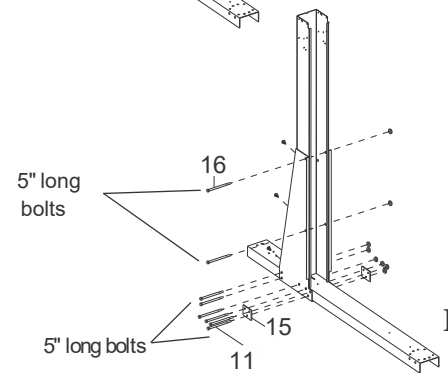

Fig. 14

E) Once all of the 5" long bolts have been tightened, install the straight side bottom connectors. This is done by placing the connector on top of the strap end channel just inside the straight side upright. The hole in the connector should line up with the hole in the strap end channel. Secure the connector to the channel using a single # 12 x 3/4" self-tapping screw for each as shown in Fig.15.

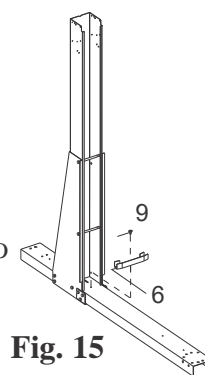

Fig. 15

PART IDENTIFIER

1	PRESSURE PLATE
2	BOTTOM RAIL, STRAIGHT SIDE
3	STRAIGHT SIDE TOP PLATE
4	STRAIGHT SIDE 4"x4" UPRIGHT
5	CHANNEL, 2" TALL
6	STRAIGHT SIDE BOTTOM CONNECTOR
7	STRAP
8	SCREWS, #10 X 1/2"
9	SCREWS, #12 X 3/4"
10	BOLTS, 5/16-18 X 1/2"
11	BOLTS, 5/16-18 X 5"
12	GUSSET, LEFT SIDE (Buttress-Free)
13	GUSSET, RIGHT SIDE (Buttress-Free)
14	UNDER BOX CHANNEL
15	WASHER, 3 HOLE
16	BOLTS 5/16-18 X 5"

*Please do not be alarmed if you are not using all of the holes in the strap end channels. We use this same channel for a few different products so there are some holes that you will not be using for this pool.

Please follow diagrams to be sure you are using all of the correct holes and hardware.

STEP 5 – STRAP ASSEMBLY FOR TRADITIONAL BUTTRESS OVAL POOLS ONLY:

*****USE THIS STEP FOR TRADITIONAL BUTTRESS OVAL INSTALLATION ONLY! IF YOU HAVE A BUTTRESS-FREE OVAL, PLEASE SEE ALTERNATE STEP 5.**

Notice that there are two different sizes of strap packed with your pool. Each strap is stamped with a part number and a length (Fig.16).

A) If your pool is 10' wide, each strap will be made up of three pieces. Two of the pieces will measure 27.25" long and one will measure 39.275" long.

B) If your pool is 12' wide, each strap will be made up of two 41.025" long pieces and one 39.275" long piece.

C) If your pool is 15' wide, each strap will be made up of four pieces. Three of the pieces will measure 40.683" long and one will measure 39.275" long.

D) If your pool is 18' wide, each strap will be made up of four pieces. Three of the pieces will measure 52.6875" long and one piece will measure 39.275" long.

E) If your pool is 21' wide, each strap will be made up of four pieces. Three of the pieces will measure 48.984" long and will measure 39.275" long.

Strap Section Chart:

	10' x 16'	12' x 17'	12' x 18'	12' x 20'	12' x 24'	15' x 24'	15' x 26'	15' x 30'	18' x 33'	18' x 40'	18' x 44'	21' x 43'
27.25"	4											
39.275"	2	2	2	2	3	2	3	4	4	6	7	7
40.683"						6	9	12				
41.025"		4	4	4	6							
48.984"												28
52.6875"									12	18	21	

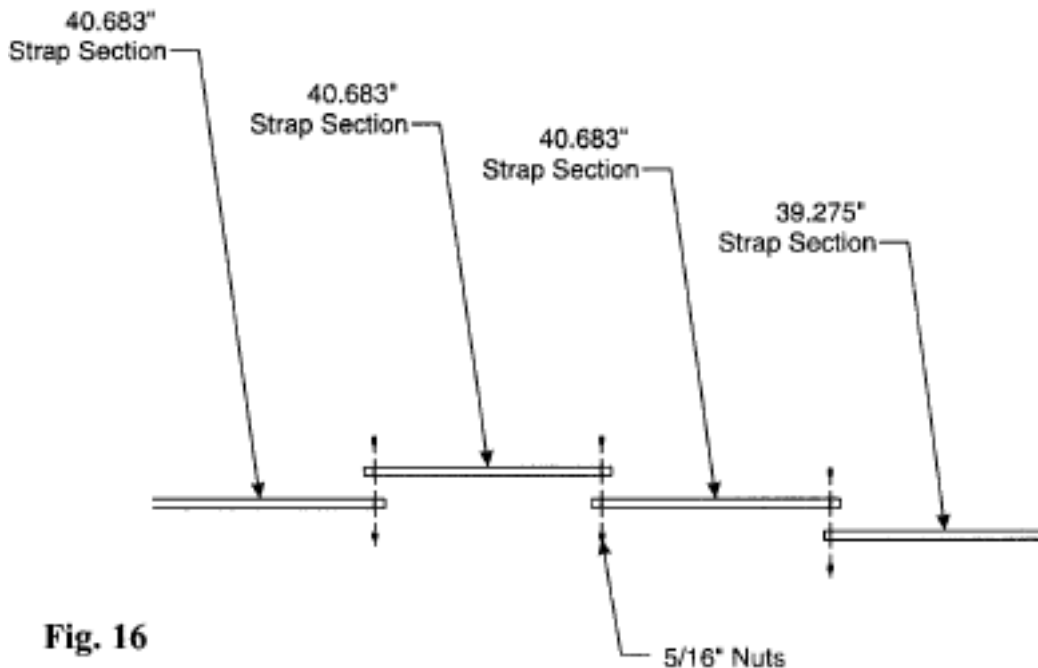

ALTERNATE STEP 5 – STRAP ASSEMBLY FOR BUTTRESS-FREE OVAL POOLS ONLY:

***** THIS ALTERNATE STEP IS FOR BUTTRESS FREE ONLY. IF YOU HAVE A TRADITIONAL BUTTRESS OVAL, GO BACK TO STEP 5.**

The straps for your pool have the same length. You will have two strap sections per complete strap for 10' wide and 12' wide oval pools, and three strap sections per complete strap for all pools 15' and 18' wide (Fig.17). If your pool is 21' wide, you will have four strap sections per complete strap.

Strap Section Chart:

	10' x 16'	12' x 17'	12' x 18'	12' x 20'	12' x 24'	15' x 24'	15' x 26'	15' x 30'	18' x 33'	18' x 40'	18' x 44'	21' x 43'
27.25"	4											
40.683"						6	9	12				
41.025"		4	4	4	6							
48.984"												28
52.6875"									12	18	21	

Secure the remaining strap sections to each other using two 5/16" x 1/2" bolts and 5/16" nuts. All holes must be used.

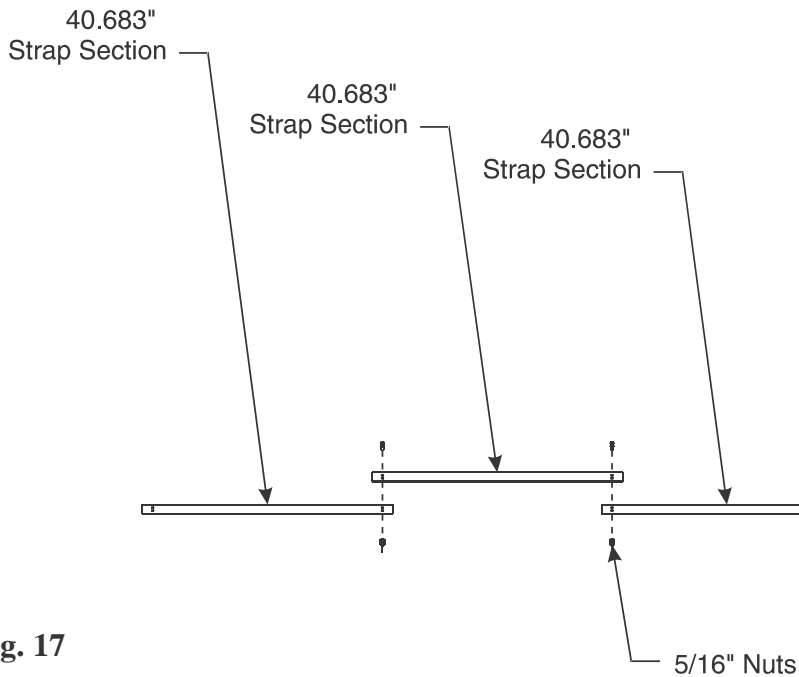

Fig. 17

STEP 6 - ATTACHING STRAPS TO STRAP END CHANNELS ON A TRADITIONAL BUTTRESS OVAL POOL ONLY:

***** USE THIS STEP FOR TRADITIONAL BUTTRESS OVAL INSTALLATION ONLY!
IF YOU HAVE A BUTTRESS-FREE OVAL, PLEASE SEE ALTERNATE STEP 6.**

After you have completed the assembly of all of the strap sections, each end of the assembled straps need to be attached to a strap end channel (Fig.18). Please keep in mind that the strap runs underneath the liner of the pool, so it should be attached to the open end of the channel, not the side where the strut connects.

The straps connect to the channels, along with the end channel caps, shown in Fig.19 and Fig.20 using two 5/16" x 1/2" bolts and two 5/16" nuts at every connection. Be sure to attach the straps to the underside of the strap end channels. The heads of the bolts go on top of the channel, and the nuts should be on the under side. Always use the two holes closest to the end of the strap end channels when connecting the strap sections to the channel.

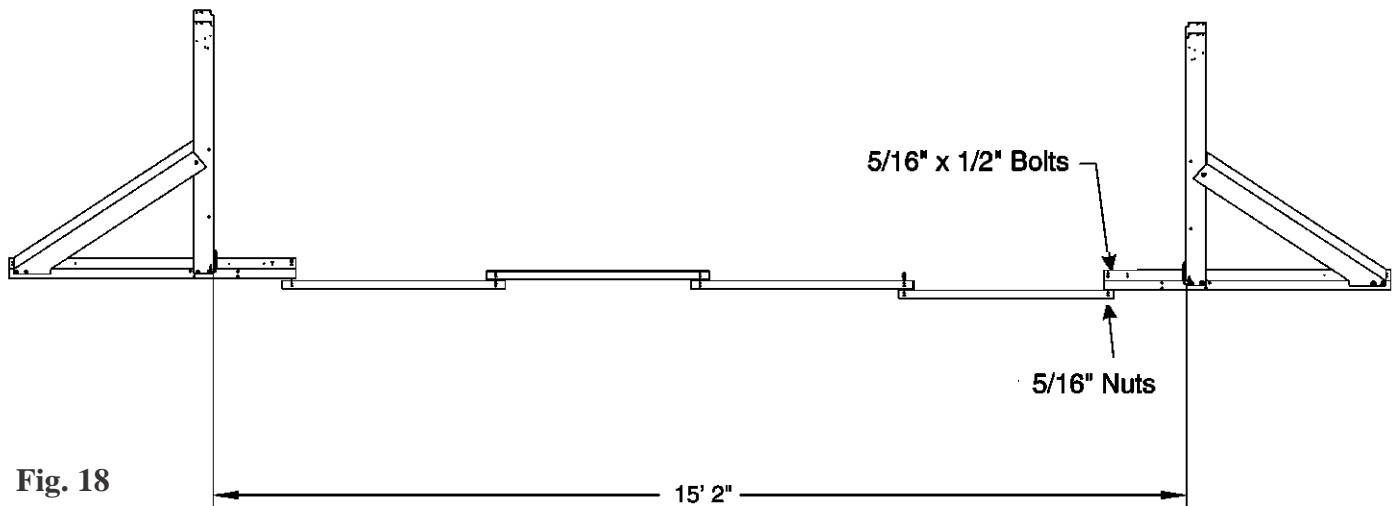

When the end channel caps are lined up properly, the two holes in these end channel caps will line up with the two holes in the straps, as well as, the corresponding holes in the strap end channels themselves.

These end channel caps are secured in place using the same two 5/16" x 1/2" bolts and 5/16" nuts that are used to secure the straps to the strap end channels.

When these parts are installed correctly they will cover the openings at the ends of the channels. This will prevent the sand base of your pool from washing into these channels once the pool is filled with water.

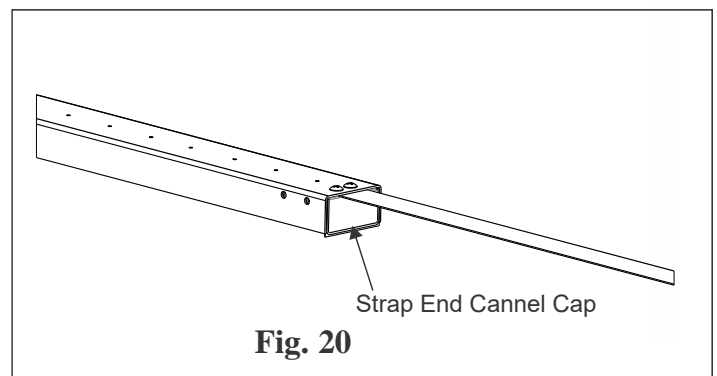
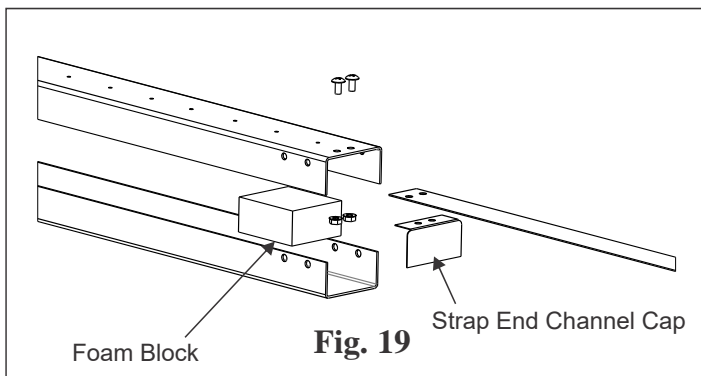

ALTERNATE STEP 6 -ATTACHING STRAPS TO STRAP END CHANNELS FOR A BUTTRESS-FREE OVAL POOL ONLY:

*****IF YOU HAVE A TRADITIONAL BUTTRESS OVAL, USE THE PREVIOUS STEP 6 FOR YOUR OVAL POOL.**

When the straps are completely assembled (as shown in Fig.21) attach each end of the straps, and an end channel cap (shown in Fig.22 and Fig.23) to a strap end channel using two 5/16" x 1/2" bolts and two 5/16" nuts at each point of connection. Note that the strap should be attached to the underside of the channels (as shown in Fig.21) with the heads of the bolts on top of the channel and the nuts on the underside of the channel. Always use the two holes closest to the end of the strap end channel when you are connecting the straps to the strap end channels (as shown in Fig.23).

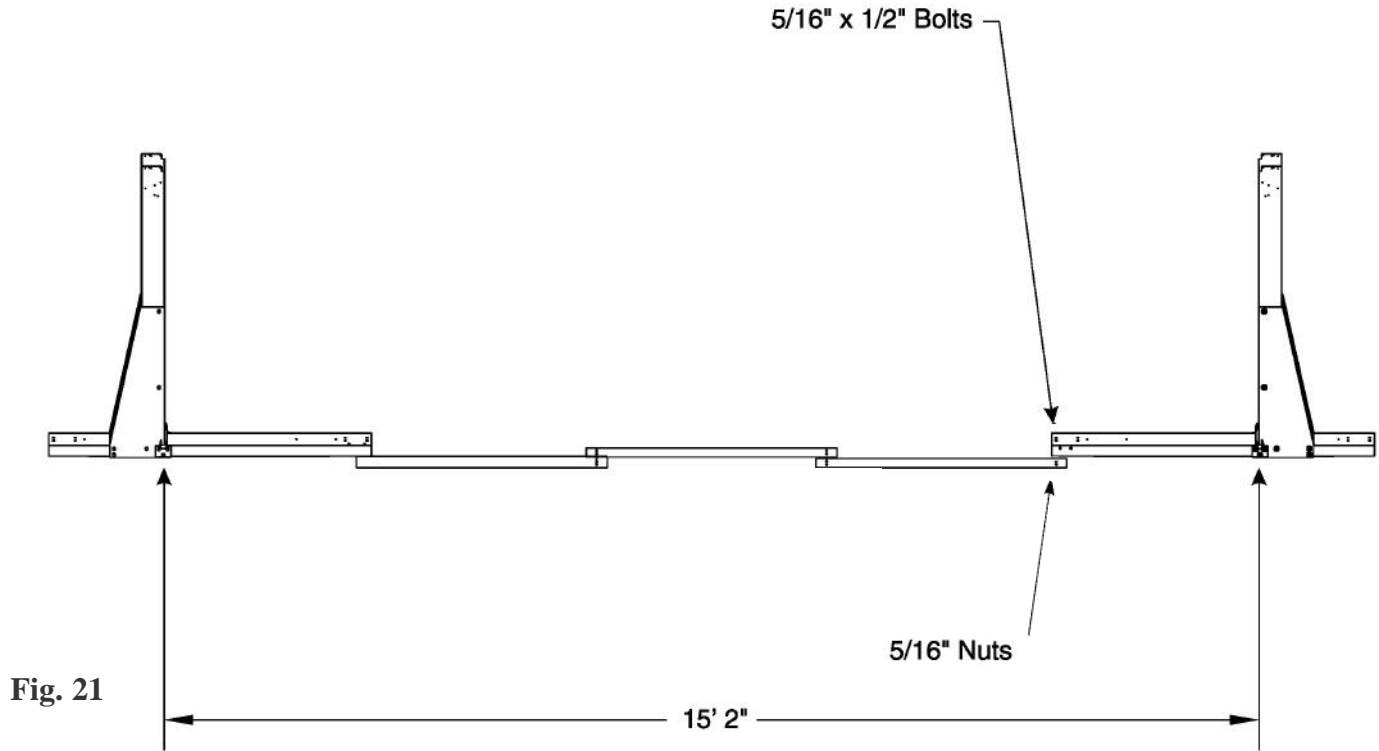

As you are bolting the strap to the strap end channels, add the end channel caps to the underside of the straps at each end as shown in Fig.22 and Fig.23.

When these end channel caps are lined up properly, the two holes in these end channel caps will line up with the two holes in the straps, as well as, the corresponding holes in the strap end channels themselves.

These end channel caps are secured in place using the same two 5/16" x 1/2" bolts and two 5/16" nuts that are used to secure the straps to the strap end channels.

When these parts are installed correctly they will cover the openings at the ends of the channels. This will prevent the sand base of your pool from washing into these channels once the pool is filled with water.

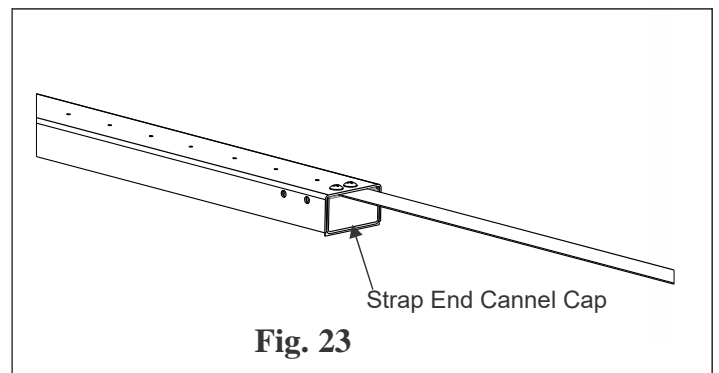
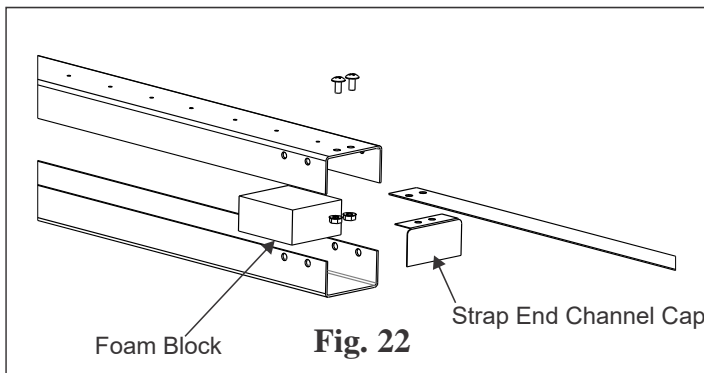

STEP 7 - STRAIGHT SIDE LAYOUT:

After all of the straps have been fully assembled and attached to the strap end channels you can now start to set them up in their final positions. (Fig.24 & Fig.25). If your pool has an odd number of straps (for example a 12' X 24' pool has three straps) find the center point of the site you leveled earlier and put the first strap and straight side upright assembly there. You then place one assembly 42", from center of strap end channel to center of strap end channel, on each side of that first assembly. Continue like this until all assemblies are used.

If your pool has an even number of straps and straight side assemblies (for example a 15' x 30' pool has four, which is pictured below) find your center point, mark it on the ground, and put an assembly on each side of that mark 21" away to the center of the strap end channels. If your pool has more than two assemblies you will put the next assemblies 42" on center from the previous assembly, as shown in Fig. 26 and Fig. 27, always keeping the same number of assemblies on each side of your center point.

Once you have all assemblies in place you want to be sure that all of the straight side uprights on one side line up with each other. This can be done fairly accurately by eye but we recommend that you use a string extending from the first upright to the last. If there are any uprights not touching the string, or that cause the string to bulge out, adjust that assembly so that the string is perfectly straight.

If you are trying to install your pool parallel to an already existing object such as a fence, simply measure from the fence to each straight side upright making sure that the measurement is exactly the same for each.

Once you are confident that one side is straight the other side should already be straight. If it does not appear to be straight, check to make sure that the straps are setting flat on the ground.

Traditional Buttress

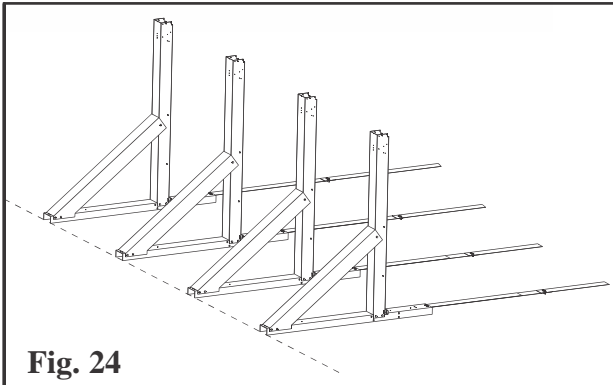

Buttress-Free

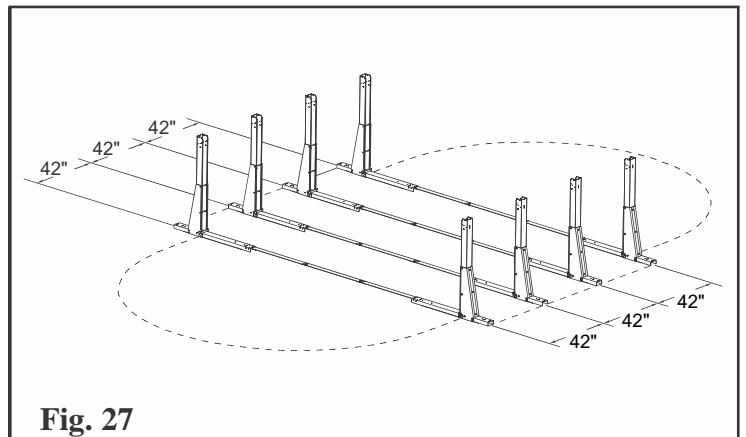
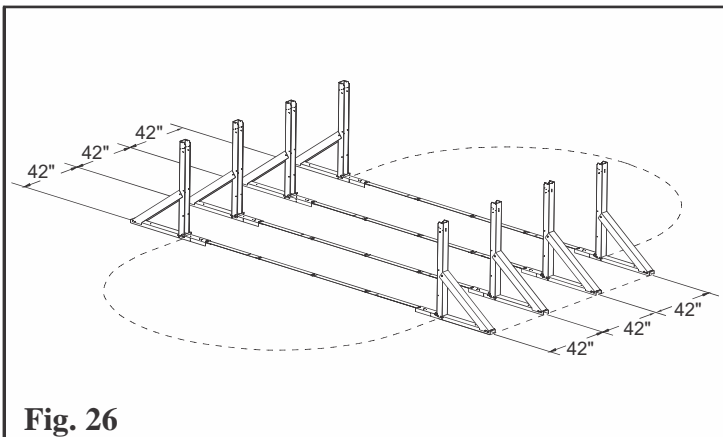
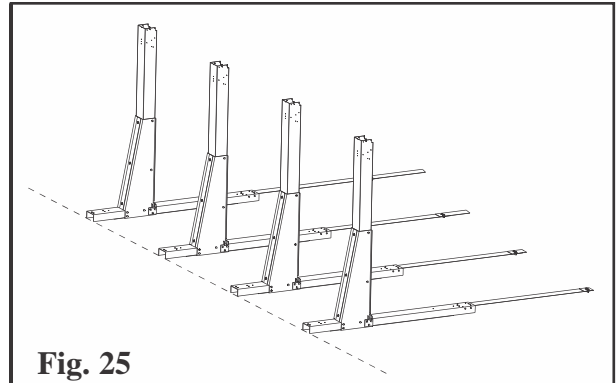

STEP 8 - BOTTOM WALL RIM ASSEMBLY:

When you unpacked the bottom wall rim you should have noticed the three different size rails (except if you have a 12' x 17' pool, in which case you only have two different sizes). Some of the rails are 37 1/2" long and some are 39" long. Reference the size chart in Step 13 for your exact pool. It is very important to separate the wall rims by size now.

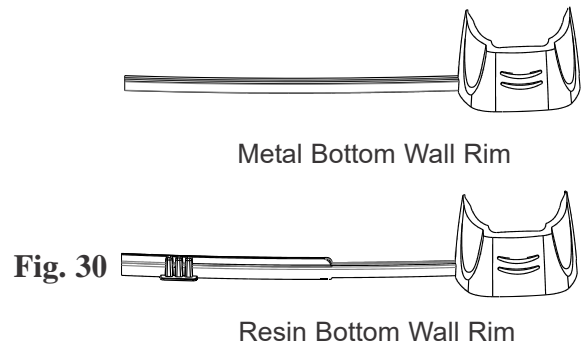
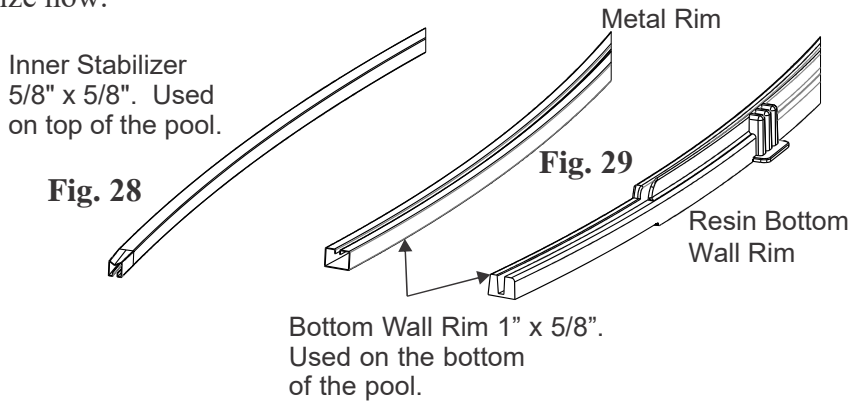

*** IMPORTANT: Make sure you are using the bottom rails and not the inner stabilizer bars. The bottom rails on some pool models are made of resin and not metal, their profile measure is about 1"X 5/8" (fig 29). Depending on you pool, the stabilizers bars can be metal or resin but the metal bars have a male and female and while the resin bars do not. Their profile measures 5/8"X5/8" (Fig.28). The bottom rails are the larger width rails that have the straight cuts on both ends. (Fig. 30). The bottom rails do not interlock.**

- The 37 1/2" long bottom wall rims go in between the straight side uprights. You simply press them down inside the straight side bottom connector on each side. These wall rims will eventually need to be sitting flat on the ground, but you can do that as you are leveling the pool.
- In most size pools, the four 39" bottom wall rims are for the "corners." One side snaps into the straight side connector on the final straight side upright, while the other side slides into a bottom plate or bottom cuff as shown in Fig.31 or Fig.32.
- You should have an even number of the longest bottom wall rims, as well as, an even number of bottom plates or bottom cuffs (depending on the model pool you have.) These will form the curved ends of your pool. Half of these wall rims and plates/cuffs will go on one end and the other half on the other end. Slide each wall rim into the plate, or cuff, up to the stop as shown. Be sure that the plate, or cuff, is outside of the half circle created on each side of the pool. Once all wall rims are assembled, you should now be able to see the entire shape of the oval pool on the ground.

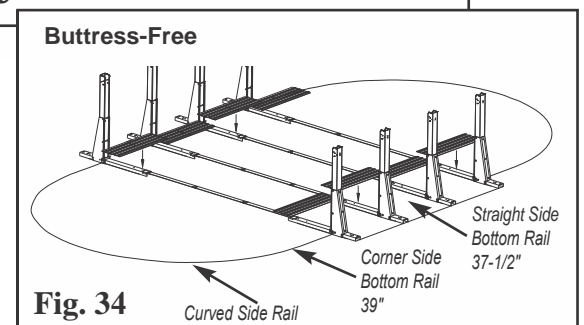
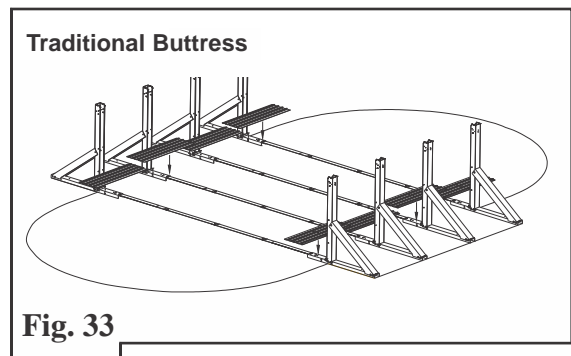
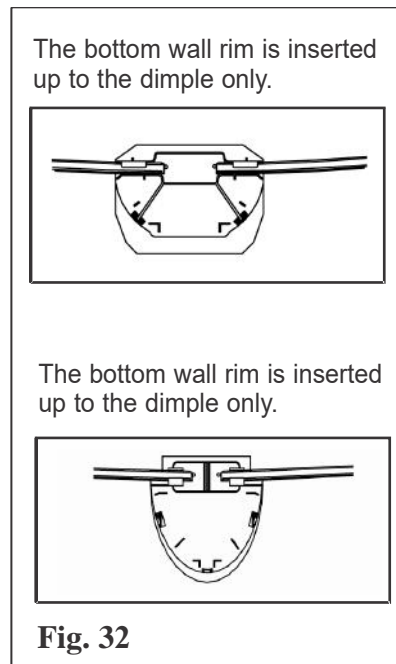
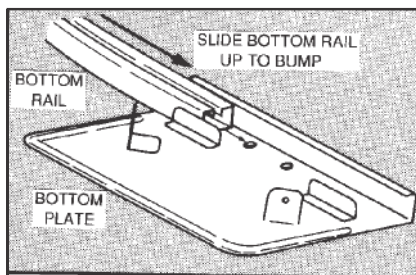

IMPORTANT: Some pools have resin bottom plates or resin bottom cuffs rather than the traditional metal bottom plate. Please refer to your pool parts breakdown sheet to confirm which component applies to you particular pool.

STEP 9- LEVELING THE STRAIGHT SIDES:

The leveling of the straight sides is a very crucial part of a good installation. If this is not done accurately it will cause a lot of problems for you.

The strap end channels are two inches deep. The top of the strap end channel needs to be level with the ground. The bottom plates or bottom cuffs on the curved sides also need to be level with the ground.

One at a time we recommend digging the strap end channels into the ground. Once all of the channels on a side are level, put a 2" x 8" x 16" patio block under the back of each strap end channel as shown in Fig.35 and Fig.36. This must be done for each strap end channel. Remember the block is two inches deep and so is the end channel. You will need to dig down a total of 4" where the block is in order to get the top of the strap end channel to ground level.

Once you have completed one entire side, do the same for every strap end channel on the opposite side. After that is complete it is a good idea to check that your straight side uprights are all level from top to bottom by using a carpenter's level. The pressure plates and straight side bottom rails ensure that your bottoms are still 42" on center. Be sure that the tops of the straight side uprights are 42" on center as well.

Traditional Buttress

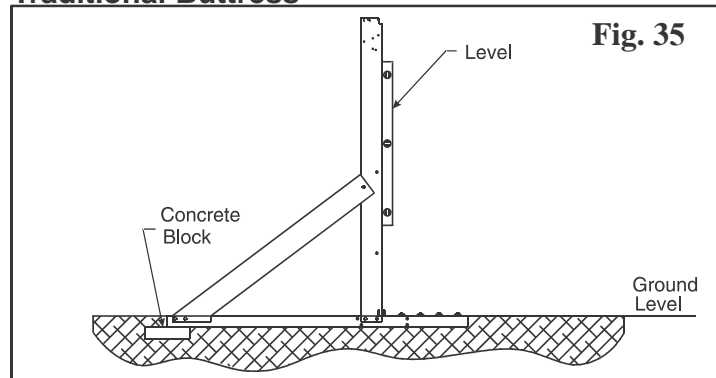

Buttress-Free

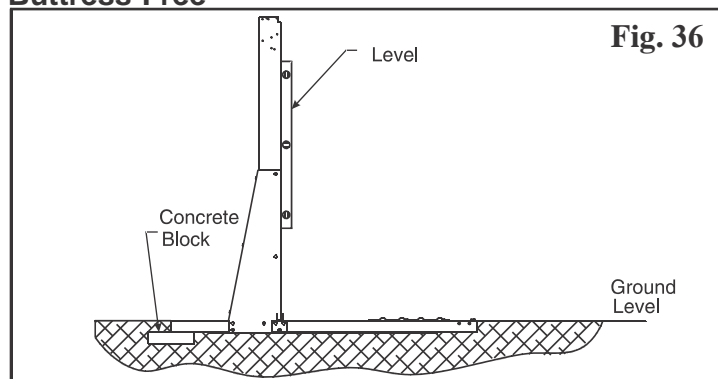

STEP 10- LEVELING THE CURVED SIDES:

The next step is to level the curved sides of the pool. Before doing this you may want to measure the overall length and width of the pool to ensure that it is the same size as shown on pages 23 - 29 of this booklet. If it is off by a couple of inches your wall will not fit properly. You can fix this situation by simply sliding the curved side bottom rails in or out of the bottom plates or bottom cuffs as shown in Fig.37a and Fig.37b. This should be done an even amount for each plate or cuff.

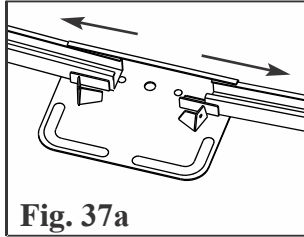

Fig. 37a

Rails can be slid in or out from the stops on the bottom plates or cuffs to adjust for wall length being a little off.

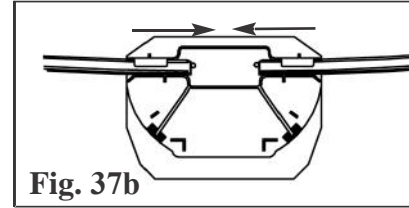

Fig. 37b

Once you are certain that the pool is the correct size, level the curved sides of the pool. Begin centering bottom plates or cuffs on 2"x8"x16" patio blocks. Sink patio block into the ground under bottom plate or cuff, making sure that the block is level in all directions (side to side as well as front to back, Fig. 38). Repeat this step around the frame making the tops of all blocks level with the ground. Do not install blocks or rails on loose, sifted soil or sand. There must be no space between the ground and the bottom of the rails. All patio blocks must be flush with the ground, solid and level with each other in all directions. You may remove a bottom rail at this time to cart in fine sand for the 3" base and for the 4" cove (Step 16), as long as your pool ring remains staked in position (Foam pool cove can be substituted for the 4" sand cove placed on top of the 3" sand bed). Make sure you replace the bottom rail in its proper position. A chalk outline of the bottom plates or cuffs on the patio block is an easy and temporary way to ensure that your track does not move throughout the remainder of the installation.

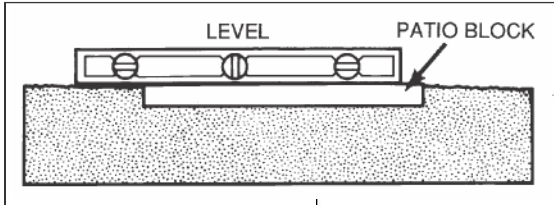

Fig. 38

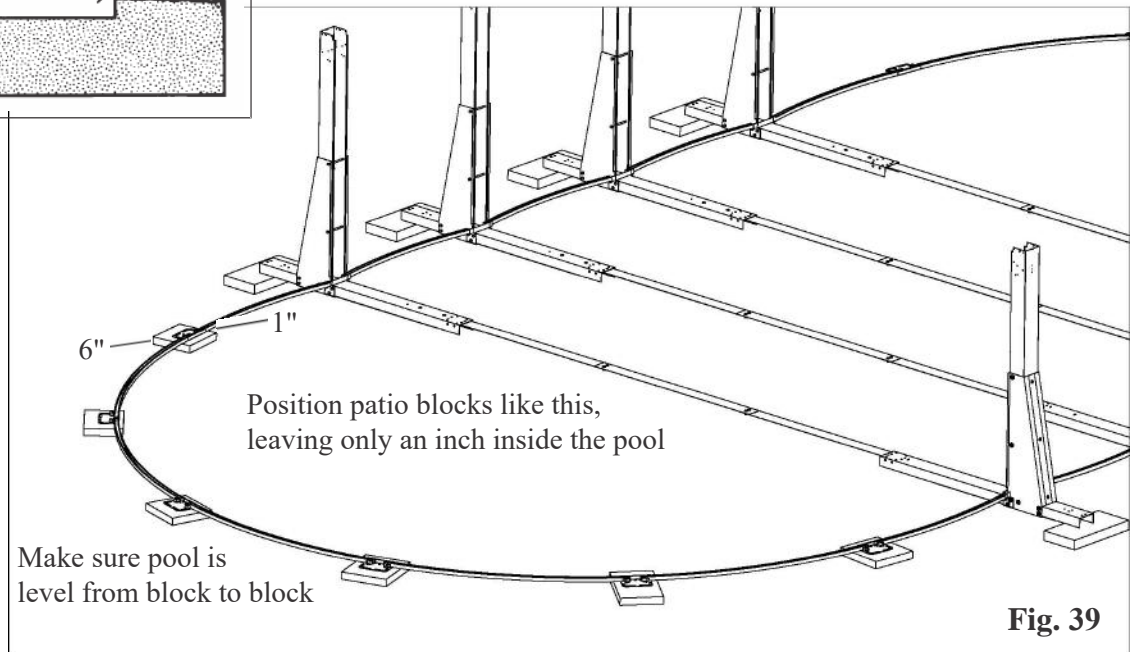

Fig. 39

NOTE: Check for levelness in all directions. When placing patio blocks under curved side bottom plates or bottom cuffs, leave 1" of the block inside the pool and 6" showing outside of the pool.

STEP 11- PRESURE PLATE INSTALLATION:

Place one 44" pressure plate on each strap end channel so that the center of the plate is even with the center of the channel. (Fig.40 & Fig.41). When installing these plates the corrugation bumps should be up and the flat surface should be down. One edge has a larger flat surface than the other. The larger flat surface should be closer to the center of the pool. **The pressure plate must extend past the end of the channel about 1" towards the center of your pool. (Fig.40A & Fig.41A).** If you have done this correctly the two holes in the center of the pressure plate line up with the two holes in the center of the strap end channel. Secure the plates to the channels using two self-tapping screws #12 X 3/4" in each. (Fig.42). Once all plates are secured to the channels, the plates should overlap each other. Secure the plates to each other using three self-tapping screws #12 x 3/4" (Fig.42) in each overlapping area.

#12 x 3/4"
Self tapping Screw



Fig. 42

Traditional Buttress

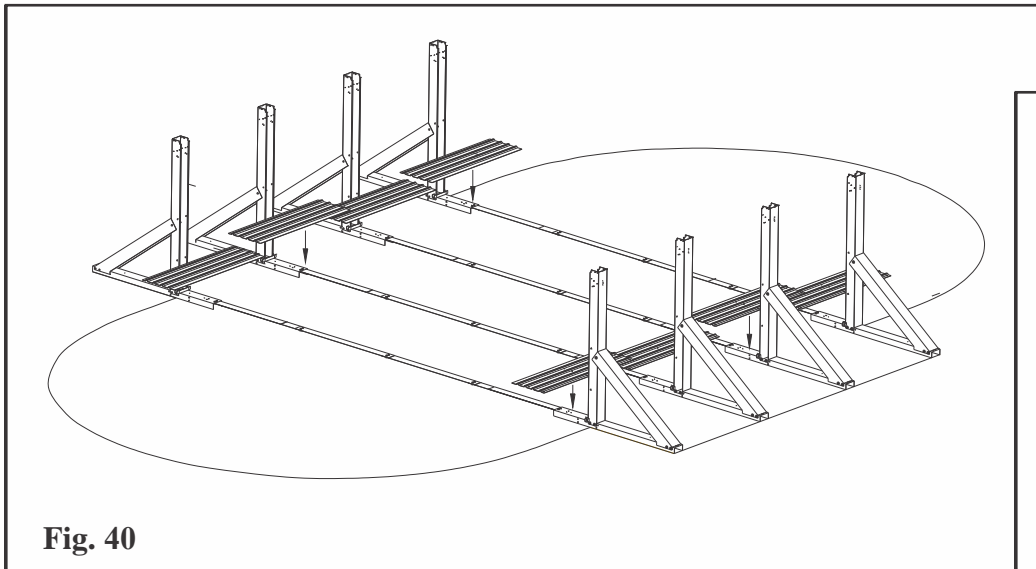

Fig. 40

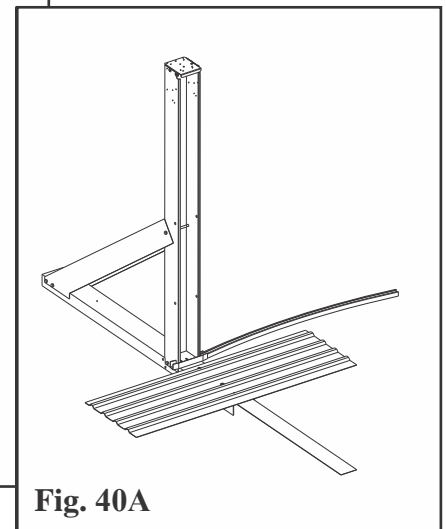

Fig. 40A

Buttress-Free

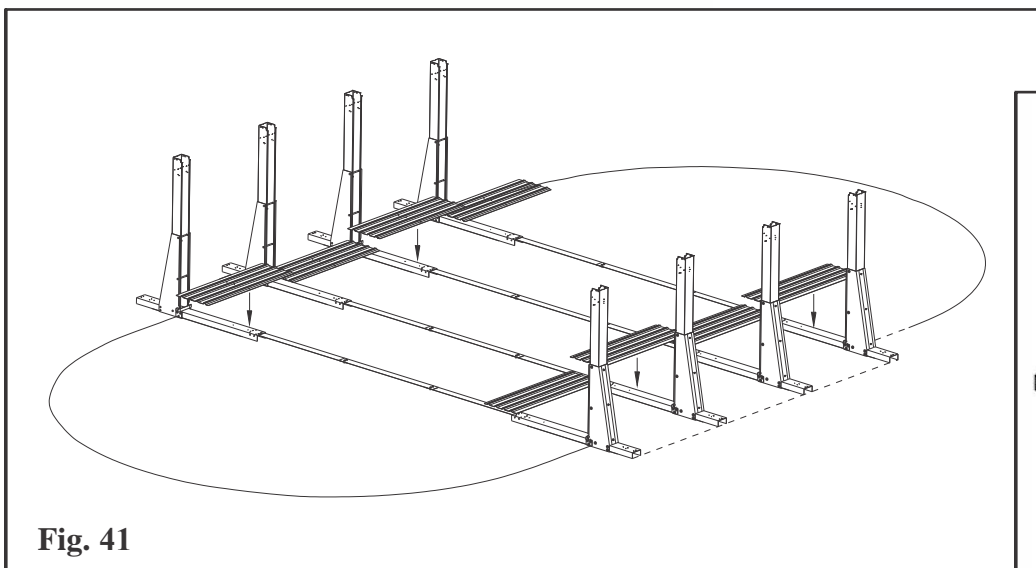

Fig. 41

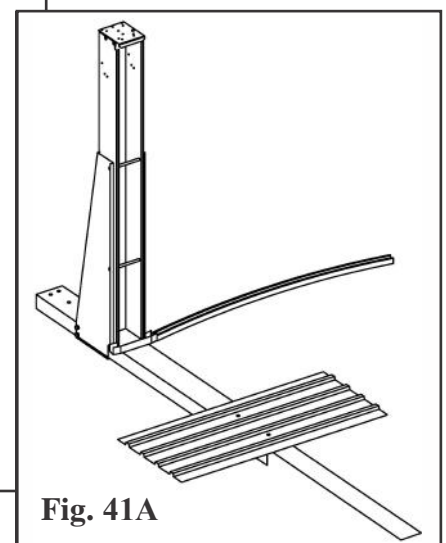
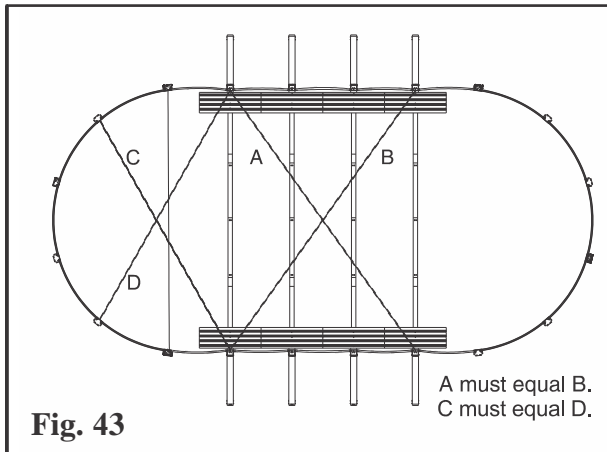

Fig. 41A

STEP 12– SQUARING THE STRAIGHT SIDES:

Now that the bottom structure of the pool is fully assembled, make sure that the straight sides of the pool are perfectly in line with each other. We refer to this as "squaring" the pool. This is done by measuring from the outside of the first straight side upright on one side, to the outside of the last straight side upright on the opposite side (the two straight side uprights farthest from each other). When making these measurements they should always be taken from the lower 12" of the straight side uprights because the higher up on the straight side upright you go, the less accurate the measurements will be. Once you have that measurement, you should measure the distance between the two opposite straight side uprights the same way (Fig.43 & Fig.44). The two measurements should be exactly the same. If they are not, adjust one entire straight side as necessary. This is a very important step, do not continue until the measurements are identical.

Traditional Buttress



Buttress-Free

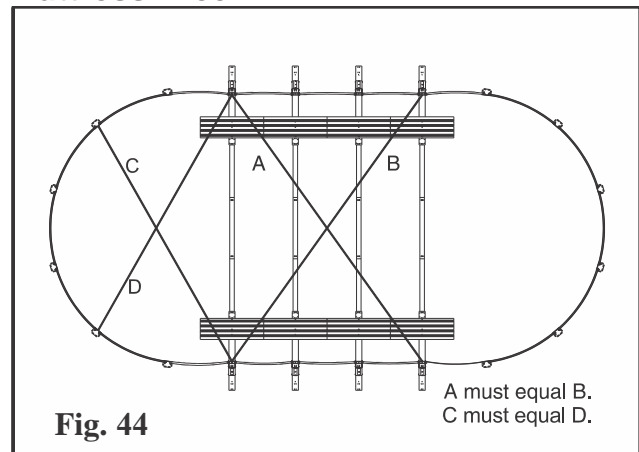

The following pages 23 - 29 show the detailed diagrams for every size oval pool that we make. Most of these measurements apply to both the Traditional Buttress oval assemblies and the Buttress-Free oval assemblies. Please use the diagram that applies to your pool to make sure you have everything in its proper position before proceeding with these instructions. Taking a few minutes to check these measurements now can save you major time and efforts down the road if something is not correct.

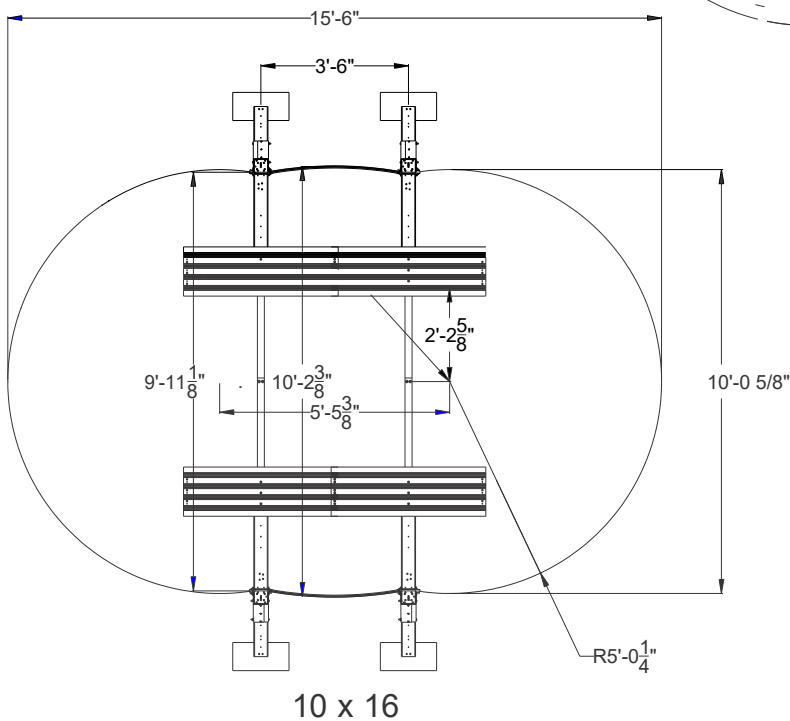
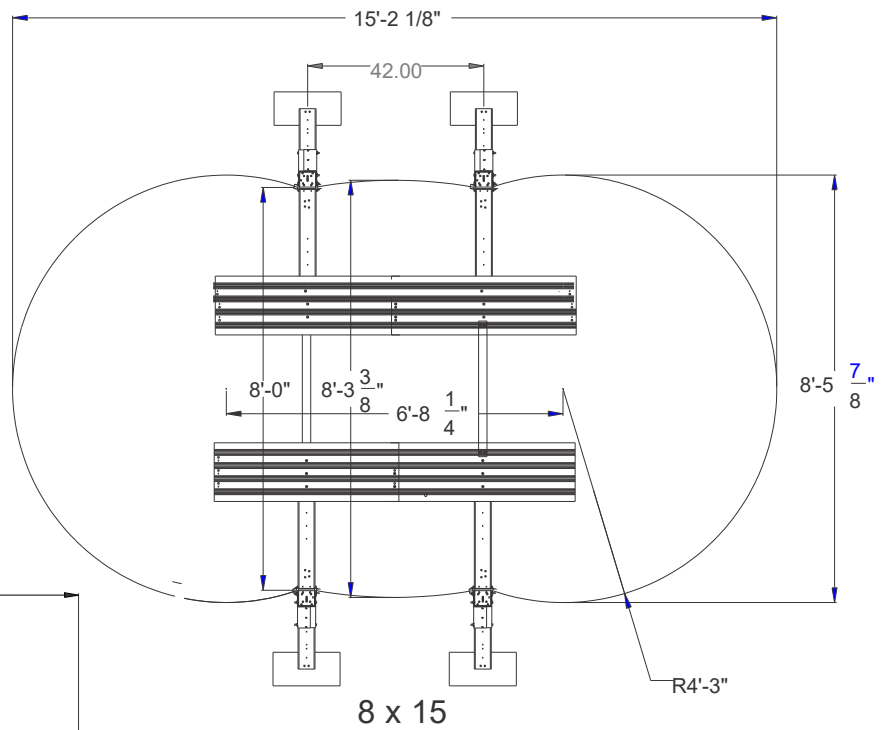
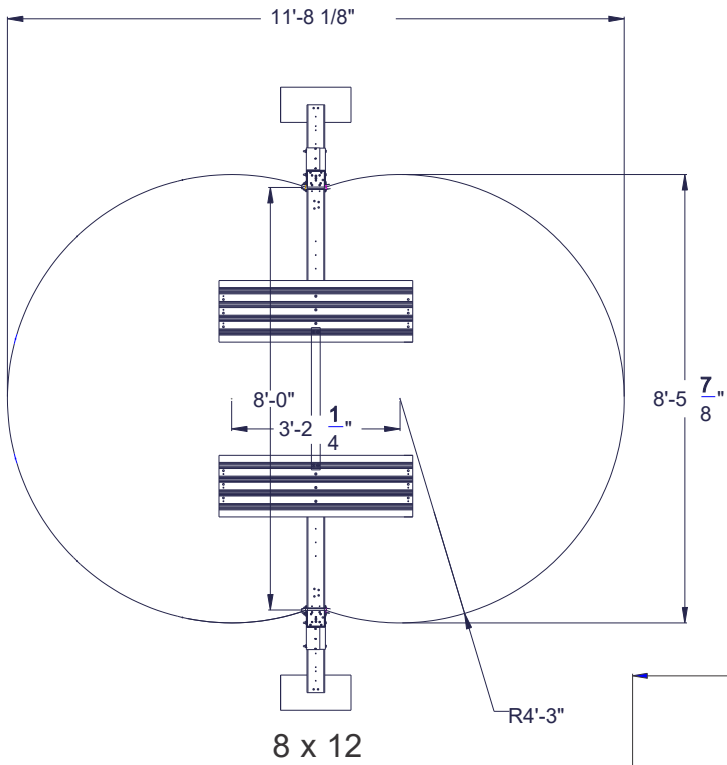

If you have a Buttress Free Space Saver pool in any of the sizes in this page, make sure to search for the addendum document in the frame carton containing the Space Saver parts. The carton will have the set of extra pressure plates needed for the Buttress Free Space Saver configuration and the information about the specific locations for them.

*All measurements are in inches unless otherwise identified.

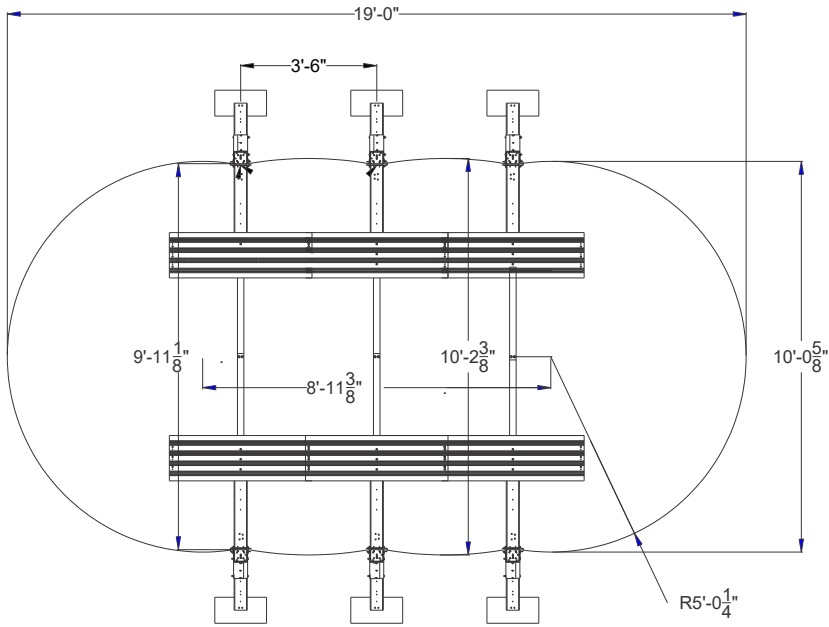

10 x 19

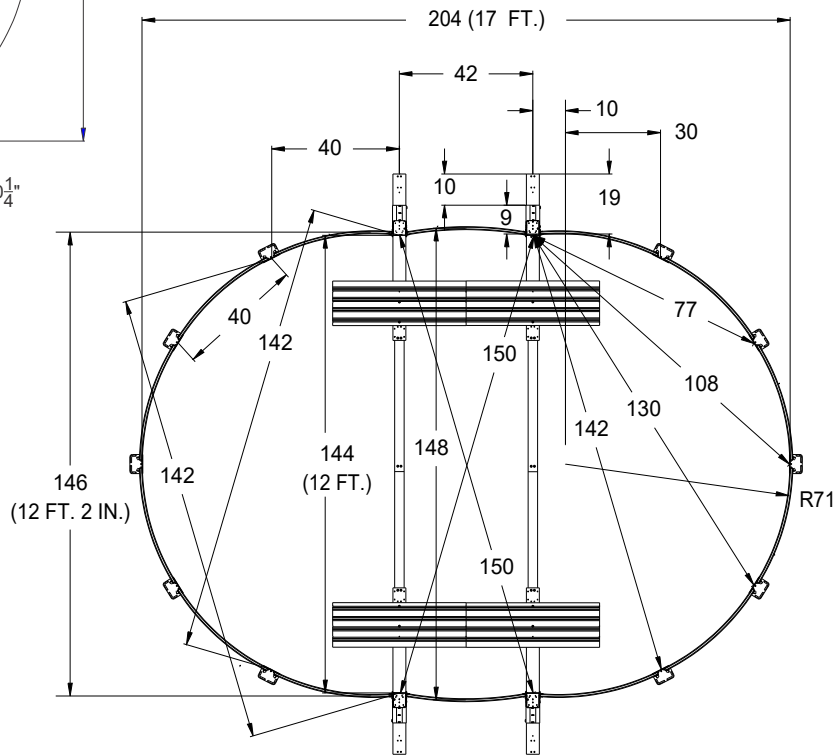

12 x 17

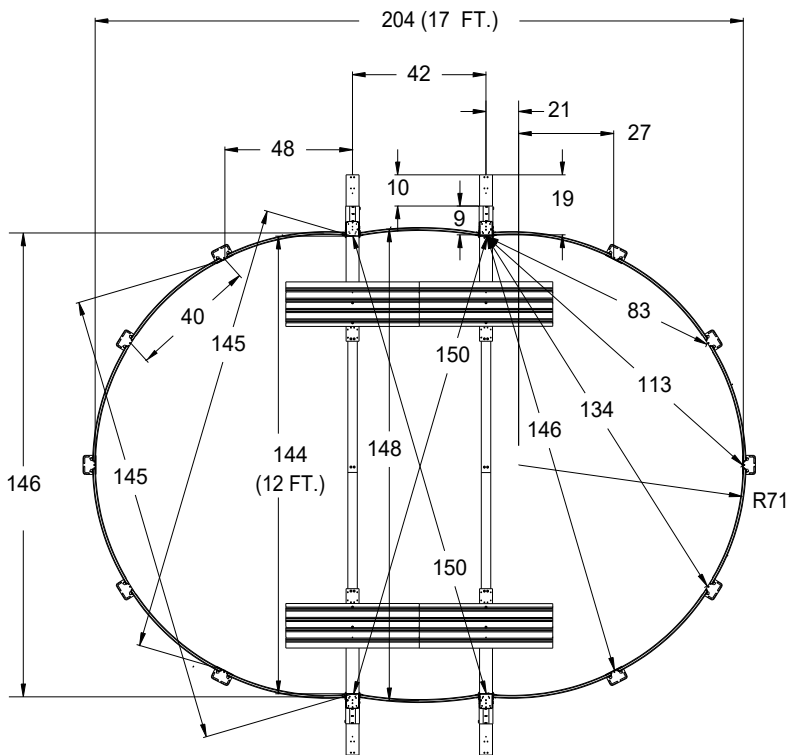

12 x 18

If you have a Buttress Free Space Saver pool in any of the sizes in this page, make sure to search for the addendum document in the frame carton containing the Space Saver parts. The carton will have the set of extra pressure plates needed for the Buttress Free Space Saver configuration and the information about the specific locations for them.

*All measurements are in inches unless otherwise identified.

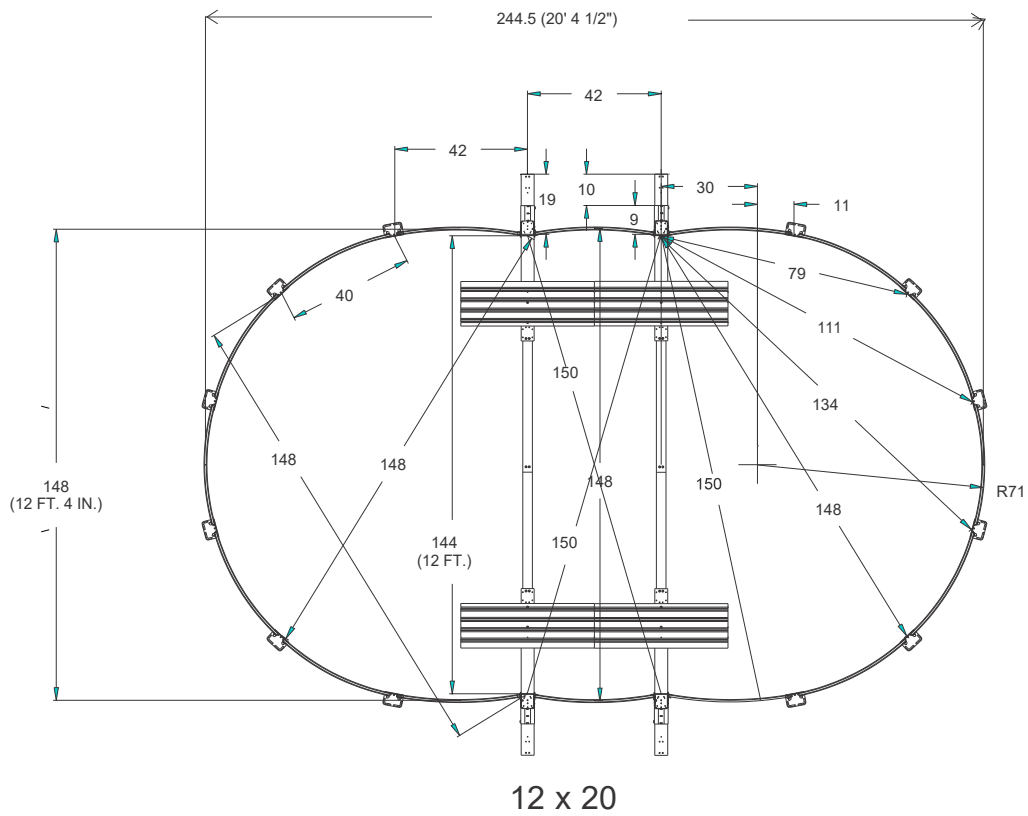

If you have a Buttress Free Space Saver 12'x20' pool, make sure to search for the addendum document in the frame carton containing the Space Saver parts. The carton will have the set of extra pressure plates needed for the Buttress Free Space Saver configuration and the information about the specific locations for them.

*All measurements are in inches unless otherwise identified.

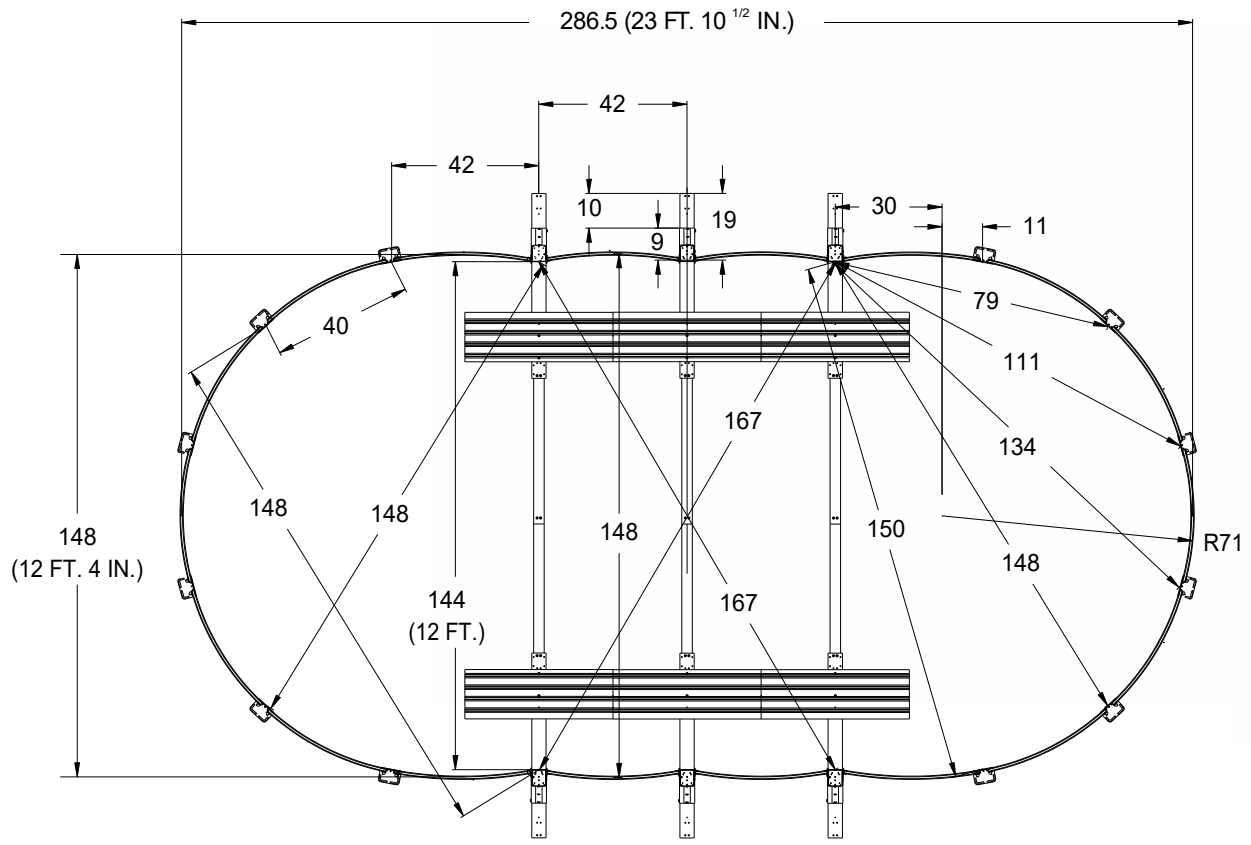

12 x 24

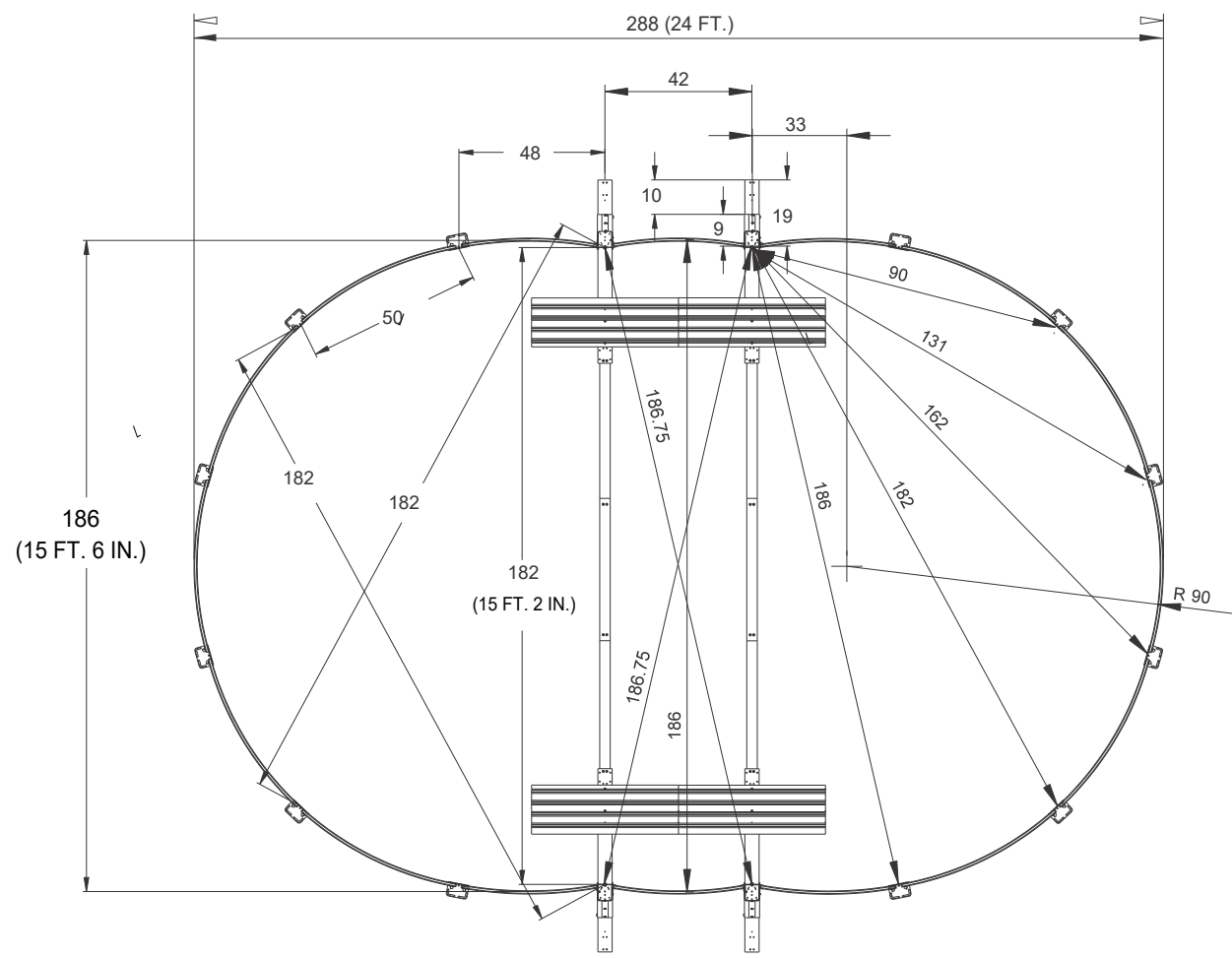

15 x 24

*All measurements are in inches unless otherwise identified.

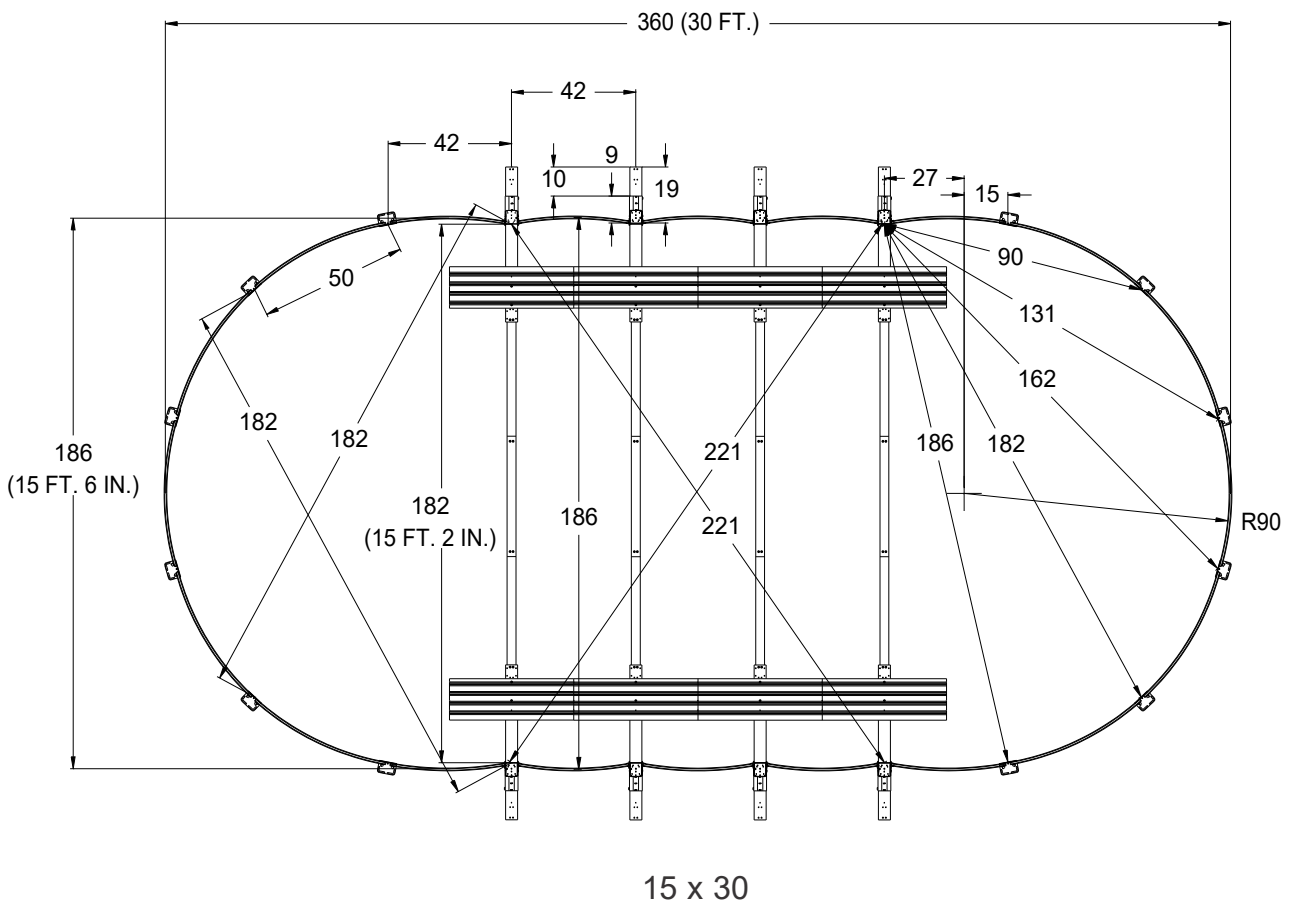
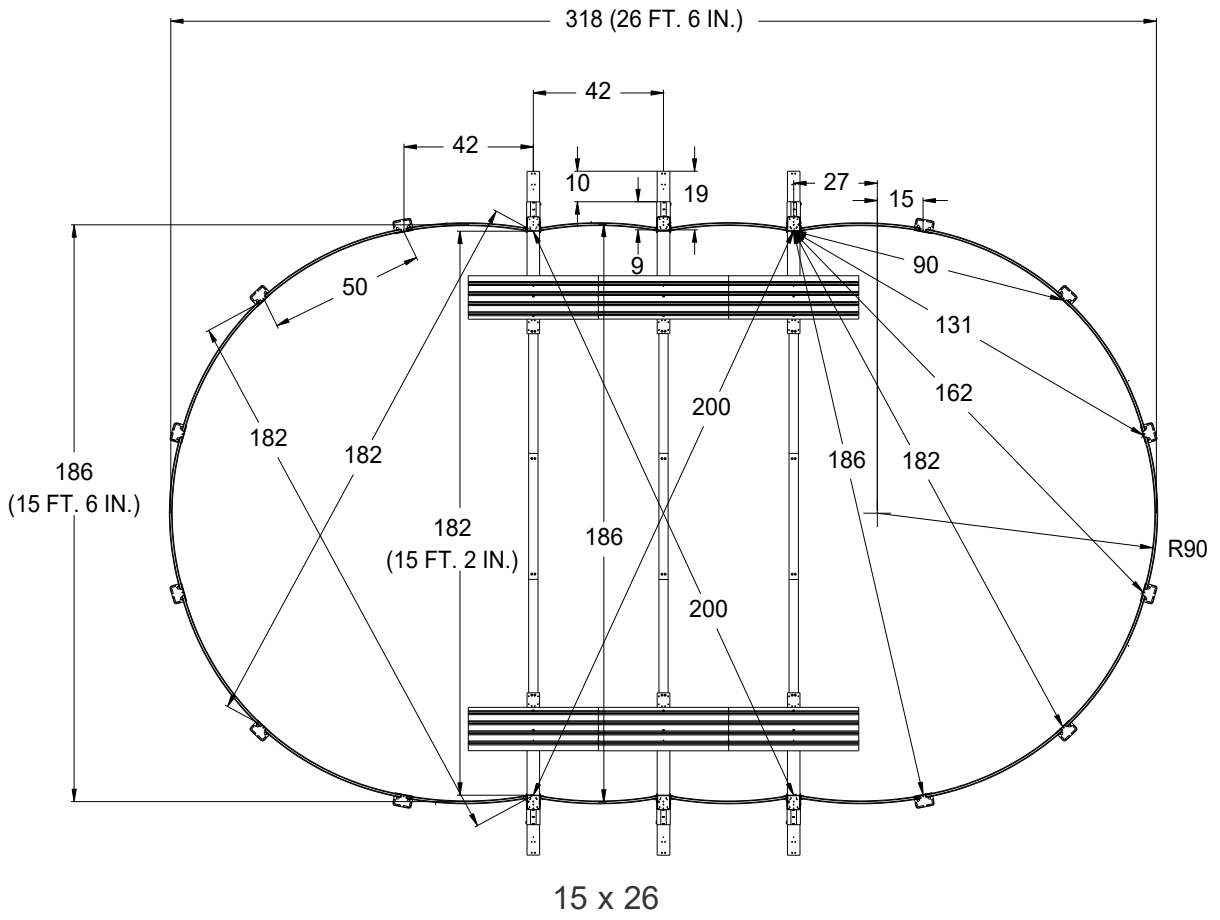

*All measurements are in inches unless otherwise identified.

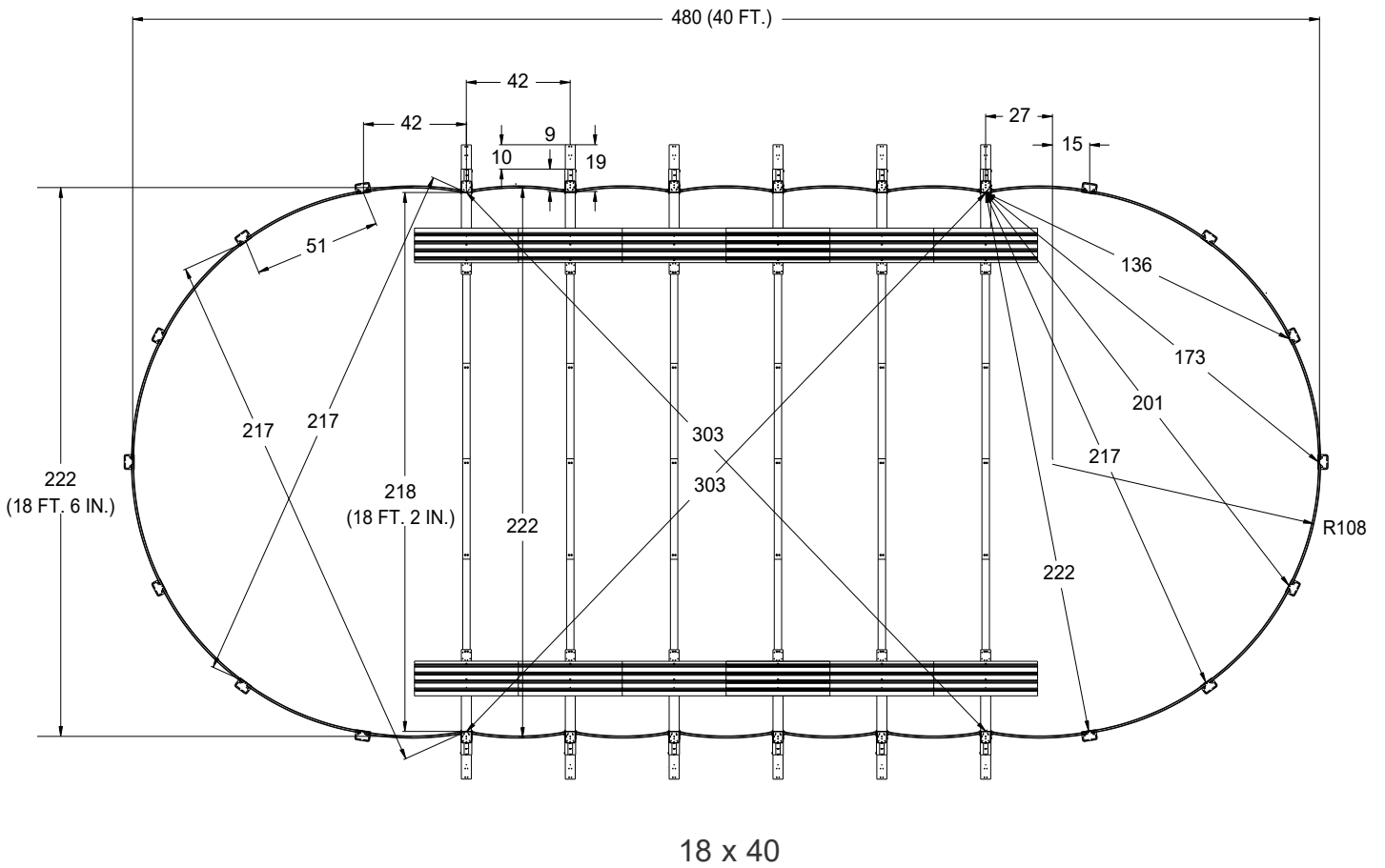
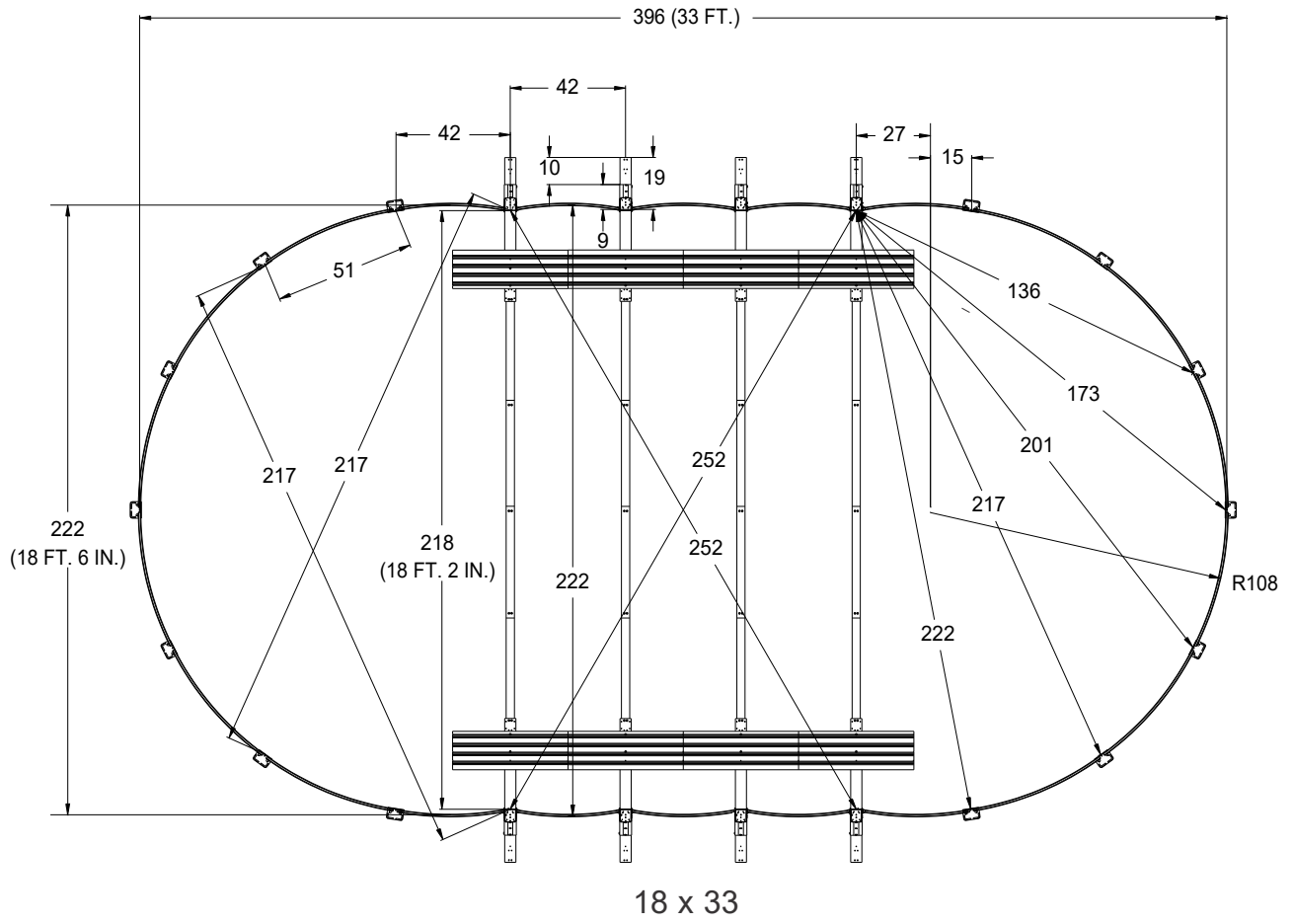

*All measurements are in inches unless otherwise identified.

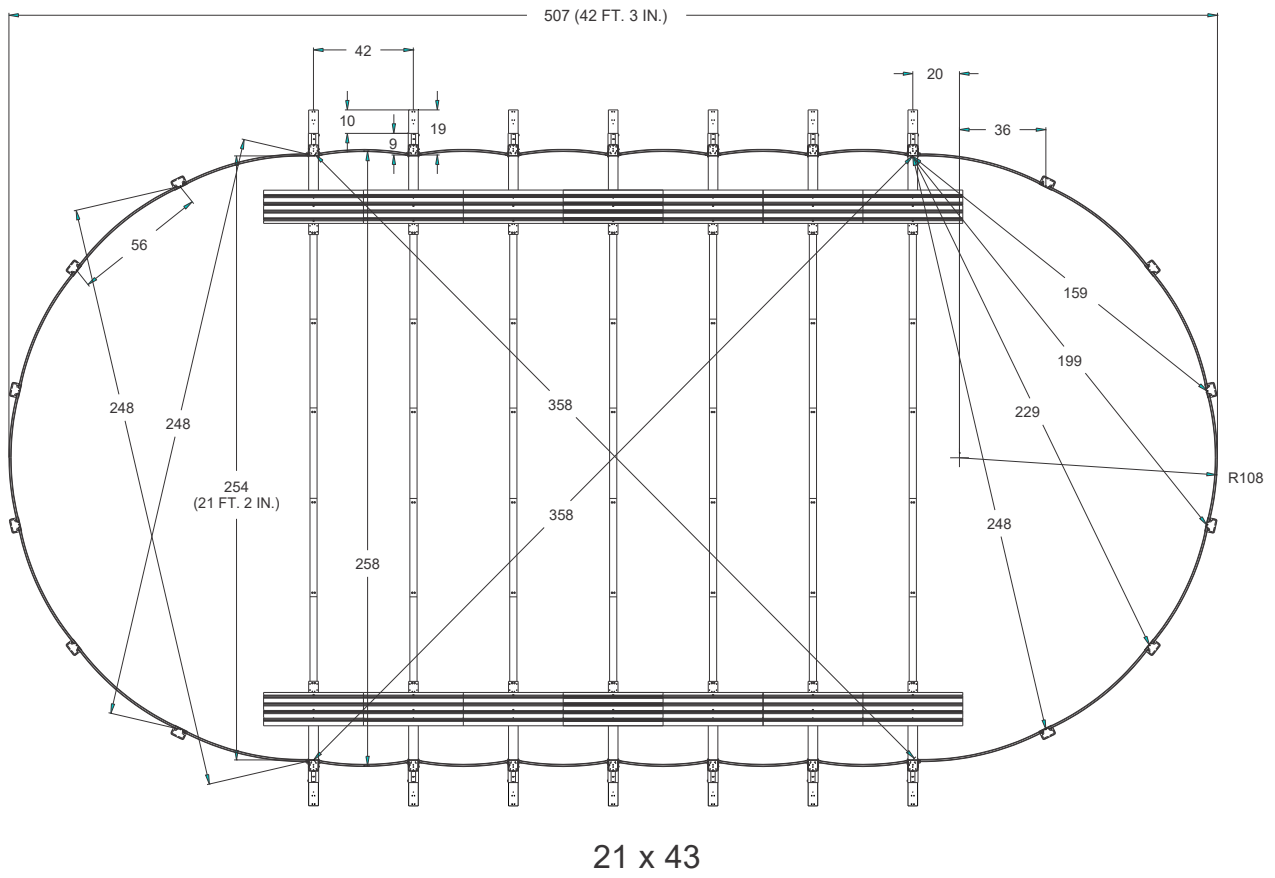
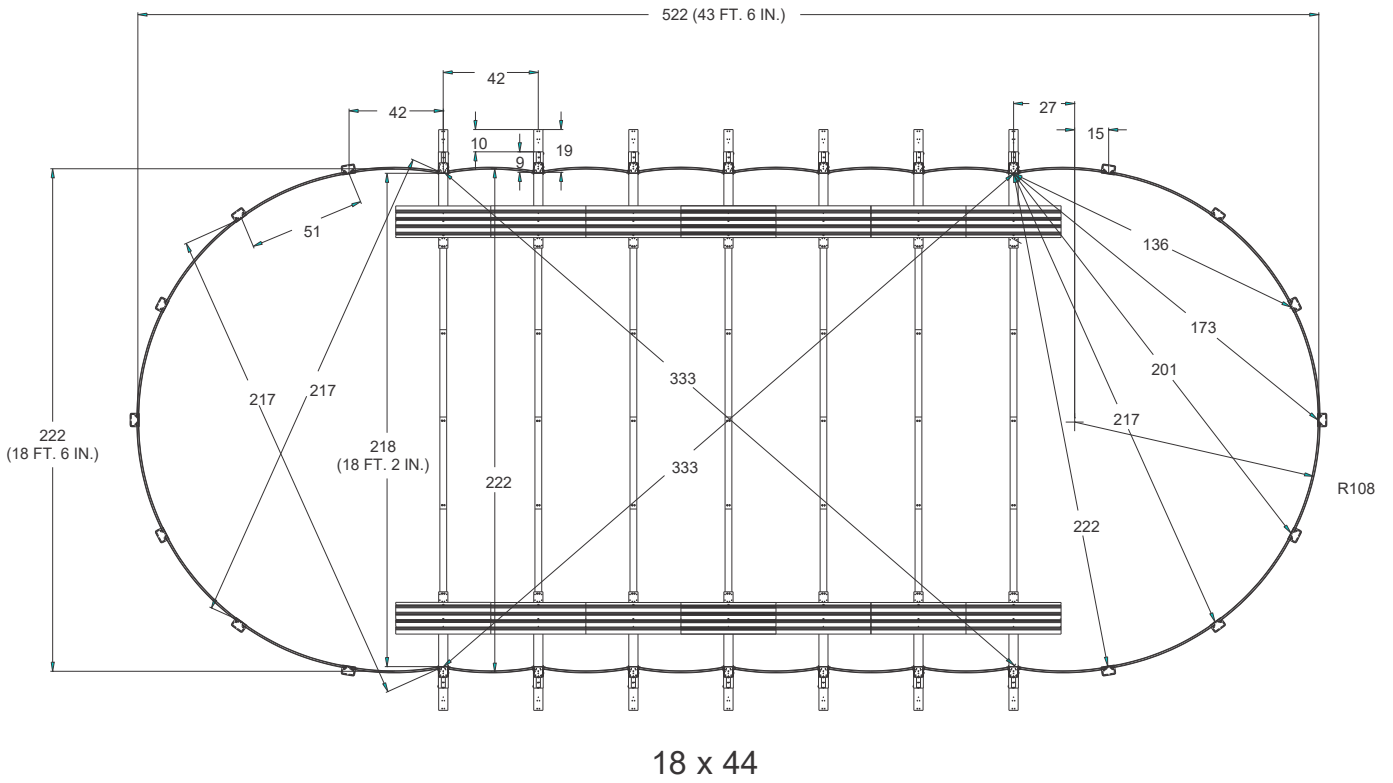

*All measurements are in inches unless otherwise identified.

STEP 13 - IDENTIFYING WALL RIMS:

When you un-pack the pool separate out the different wall rims that go in different parts of the pool. This is very important. Incorrect placement of the rims will result in a pool that needs to be re-installed. The rims that go on the bottom of the pool are called Bottom Rails or Bottom Wall Rims. The Bottom Rails are 1" wide. The rims that go on the top of the pool wall are called Inner Stabilizers. The Inner Stabilizers are 5/8" wide. See the chart to see where each part is installed on the swimming pool.

BOTTOM RAIL AND STABILIZER LAYOUT

Oval		8x12	8x15	10x16	10x19	12x17	12x18	12x20	12x24	15x24	15x26	15x30	18x33	18x40	21x43
BOTTOM WALL RAIL CURVED END OF OVAL	QUANTITY	10	10	6	6	12	8	10	10	10	10	10	12	12	10
	LENGTH	25-1/4"	25-1/4"	38"	38"	38"	38"	38"	38"	49"	49"	49"	50"	50"	54-1/4"
	RADIUS	4'0"	4'0"	5'6"	5'6"	5'6"	5'6"	5'6"	5'6"	7'6"	7'6"	7'6"	9'0"	9'0"	10'6"
TOP WALL STABILIZER CURVED END OF OVAL	QUANTITY	10	10	6	6	12	8	10	10	10	10	10	12	12	10
	LENGTH	29-1/2"	29-1/2"	42-5/8"	42-5/8"	42-5/8"	42-5/8"	42-5/8"	42-5/8"	53-1/4"	53-1/4"	53-1/4"	54-1/8"	54-1/8"	54-7/16"
	RADIUS	4'0"	4'0"	5'6"	5'6"	5'6"	5'6"	5'6"	5'6"	7'6"	7'6"	7'6"	9'0"	9'0"	10'6"
BOTTOM WALL RAIL TRANSITION (4 CORNERS)	QUANTITY	4	4	4	4	N/A	4	4	4	4	4	4	4	4	4
	LENGTH	27-1/4"	27-1/4"	42-5/8"	42-5/8"	N/A	45"	39"	39"	45"	39"	39"	39"	39"	53-1/2"
	RADIUS	9'0"	9'0"	9'0"	9'0"	N/A	9'0"	9'0"	9'0"	9'0"	9'0"	9'0"	9'0"	9'0"	10'6"
TOP WALL STABILIZER TRANSITION (4 CORNERS)	QUANTITY	4	4	4	4	N/A	4	4	4	4	4	4	4	4	N/A
	LENGTH	29-1/2"	29-1/2"	41-3/8"	41-3/8"	N/A	43"	37"	37"	43"	37"	37"	37"	37"	N/A
	RADIUS	9'0"	9'0"	9'0"	9'0"	N/A	9'0"	9'0"	9'0"	9'0"	9'0"	9'0"	9'0"	9'0"	N/A
BOTTOM WALL RAIL STRAIGHT SIDE OF OVAL (BETWEEN STRAIGHT SIDE UPRIGHTS)	QUANTITY	N/A	2	2	4	2	2	2	4	2	4	6	6	10	12
	LENGTH	N/A	37-1/2"	37-1/2"	37-1/2"	37-1/2"	37-1/2"	37-1/2"	37-1/2"	37-1/2"	37-1/2"	37-1/2"	37-1/2"	37-1/2"	37-1/2"
	RADIUS	N/A	9'0"	9'0"	9'0"	9'0"	9'0"	9'0"	9'0"	9'0"	9'0"	9'0"	9'0"	9'0"	9'0"
TOP WALL STABILIZER STRAIGHT SIDE OF OVAL (BETWEEN STRAIGHT SIDE UPRIGHTS)	QUANTITY	N/A	2	2	4	2	2	2	4	2	4	6	6	10	12
	LENGTH	N/A	33"	33"	33"	33"	33"	33"	33"	33"	33"	33"	33"	33"	33"
	RADIUS	N/A	9'0"	9'0"	9'0"	9'0"	9'0"	9'0"	9'0"	9'0"	9'0"	9'0"	9'0"	9'0"	9'0"
TOP WALL STABILIZER STRAIGHT SIDE OF OVAL (AT EACH STRAIGHT SIDE UPRIGHT)	QUANTITY	2	4	4	6	4	4	4	6	4	6	6	8	10	12
	LENGTH	8"	8"	8"	8"	8"	8"	8"	8"	8"	8"	8"	8"	8"	8"
	RADIUS	9'0"	9'0"	9'0"	9'0"	9'0"	9'0"	9'0"	9'0"	9'0"	9'0"	9'0"	9'0"	9'0"	9'0"

Note: There are different variations between pool models. You will either have Steel or Resin Bottom Wall Rims.

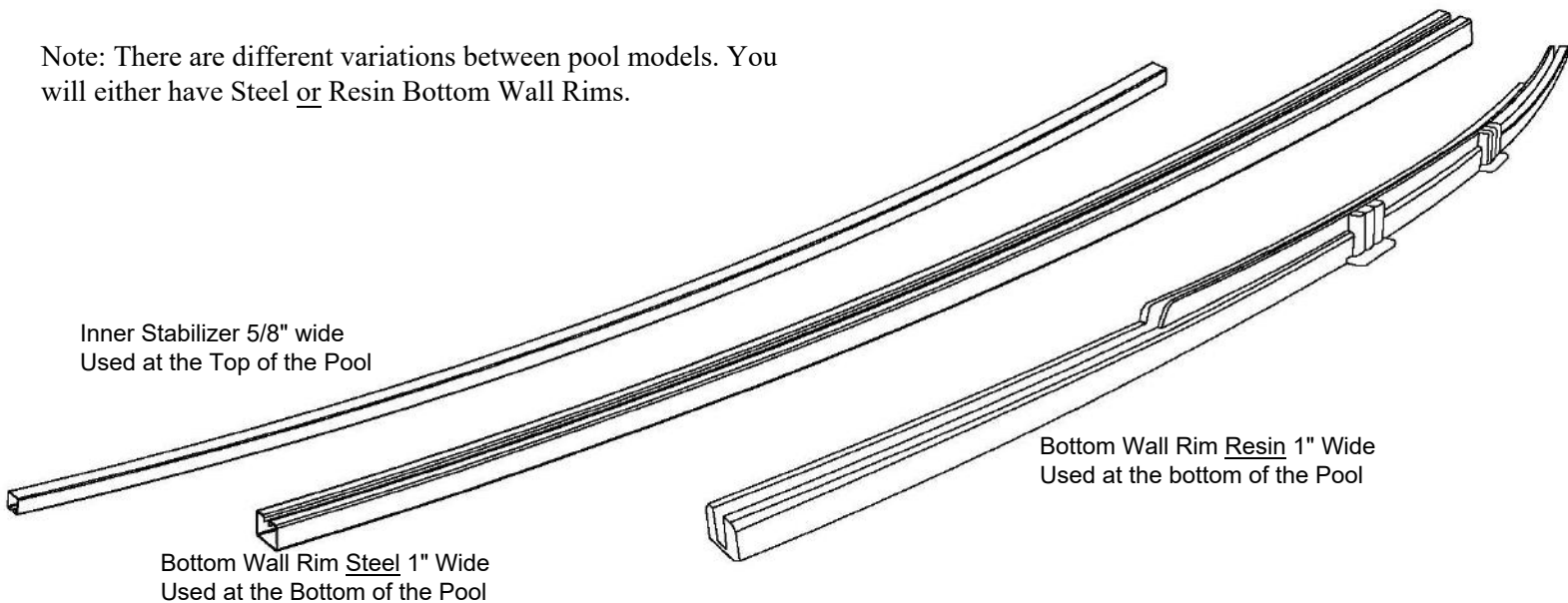

STEP 14 – WALL INSTALLATION

***** DO NOT ATTEMPT THIS STEP IN WINDY CONDITIONS. THE WALL IS VERY HEAVY AND EXTREMELY DIFFICULT TO MANAGE ON A WINDY DAY. IF THE WIND DOES CATCH THE WALL DURING INSTALLATION, IT CAN CREATE DANGEROUS SITUATIONS AND/OR CAUSE DAMAGE TO THE POOL.**

Before beginning the wall installation, you may remove a curved side bottom rail to cart in sand for the 3" pool base and 4" pool cove as long as your curved sides are staked in position (Foam pool cove can be substituted for the 4" sand cove placed on top of the 3" sand bed). Make sure you replace the bottom rail in its proper position.

In this step, you should flatten the carton the wall came packed in and use that as a base to unravel the pool wall as you install it. We recommend the skimmer and return hole to be placed at one of the four corners of the curved sections of the pool (as shown in Fig.45). The skimmer location is determined by where you start the wall. You can hide the wall joint assembly on most size pools by beginning the wall in the middle of one of the curved side bottom plates or bottom cuffs. Unfortunately, you will not be able to hide the wall joints behind an upright on some of the smaller size oval pools. Doing so will cause your skimmer and/or return punch out to fall behind an upright, which you cannot have. In any case, the wall joints **MUST** be on one of the curved ends of the pool and not on one of the straight sides.

Unravel the wall a little at a time, inserting it into the bottom rails as you go. Do not unravel the entire wall at once, as doing so will make the installation much more difficult. As you unravel the wall, you may temporarily install the stabilizer rails, or use landscaping stakes with clamps to keep the wall in place (Fig.46 & Fig.46A). We recommend that in addition to the stabilizer rails or stakes that you temporarily use small pieces of duct tape from the top of the wall to the top of each of the straight side uprights as added support during installation.

If the sidewall appears too long or too short, make the curved sides larger or smaller by equally sliding the bottom rails in or out of the bottom plates or cuffs. If the ground is uneven, the wall may jump out of the groove in the bottom rails. Correct this condition if it happens by rechecking the level of the entire pool.

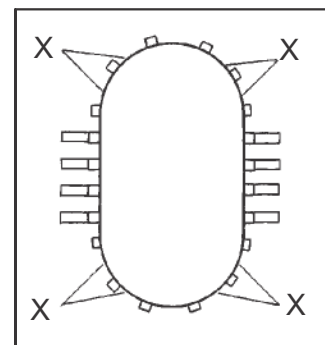
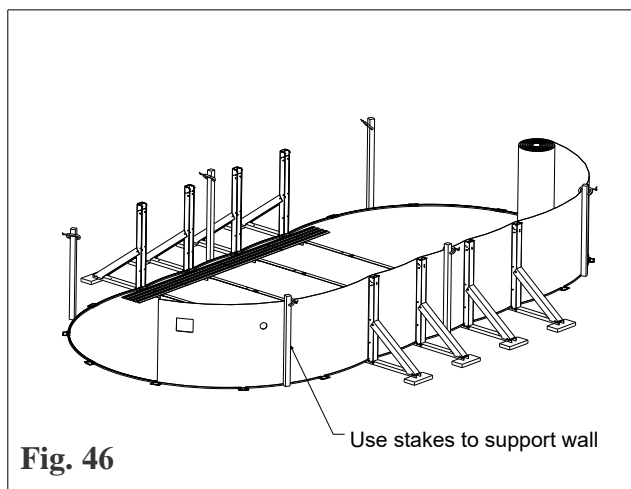
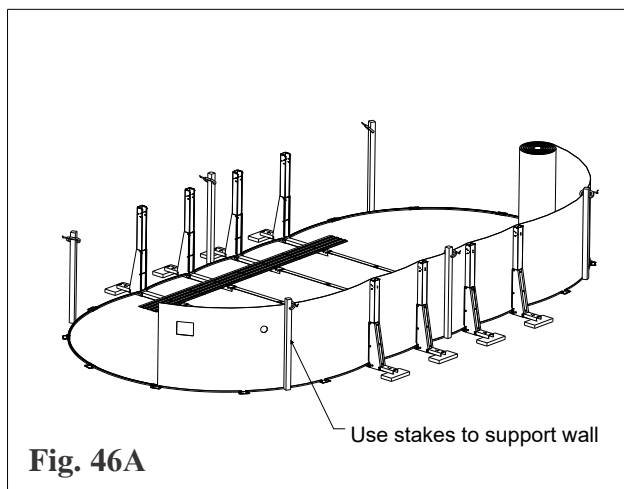

Fig. 45

Traditional Buttress



Buttress-Free



STEP 14 – WALL INSTALLATION (Cont.)

It is extremely important at this stage that the pool wall and the pool tracks form the proper pool size on the ground. Once the wall is installed go around the pool and re-check the shape of the pool on the ground. Pull / push any bottom tracks back into the proper pool shape. Make sure that the bottom tracks are not “trapped” and can easily move on the ground away from the water. The bottom of the pool needs to be able to move out as the pool is filled with water and the pool wall takes the water pressure. Any problems at this step show up at the end of the pool installation when you put water into the pool. Evidence of incorrect pool shape or bottom rails being unable to move will show up on a filled pool as:

- The pool wall buckles in only some areas, usually close to the ground
- The pool upright spreads out, usually close to the ground
- The wall bulges out of the bottom track and sometimes comes completely out of the bottom track.
- The bottom track leans out, away from the water
- The pool wall and uprights are not vertical, but leaning into or away from the water

To fix any of these problems requires that the whole pool be taken down and re-installed.

***** We manufacture two different kinds of wall joint assemblies. One has a single row of bolts with wall bars, and the other is a staggered double row pattern with wall bars. Please check which design your pool has and follow the appropriate instructions below.**

Type #1 Single Row

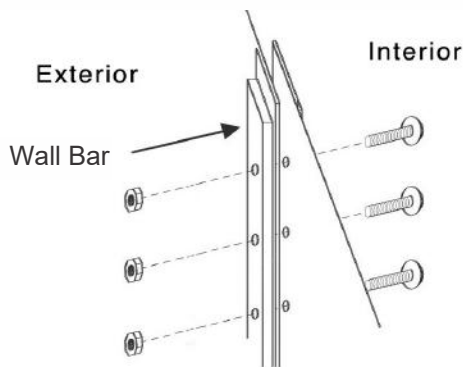

Fig. 47

IMPORTANT-This operation must be done carefully! When joining the sidewall, make sure that the strips do not touch each other. One bar must be inside the pool (the bolts will touch this bar) and one bar must be outside the pool (the nuts will touch this bar). Insert the bolts with the bolt head to the inside and the nuts to the outside of the pool. Do not tighten until all bolts have been inserted. If your screwdriver slips and scratches the head of the bolt, file the scratch smooth so that it cannot puncture the liner. It is recommended that you cover the heads of the bolts, on the inside of the wall, with three layers of duct tape. If the insertion of the wall in the bottom rail is tight at the point where the wall is joined together, insert a screwdriver and twist to make enough room, again being sure not to scratch the wall or the bottom rail.

REMEMBER:
ALL NUTS SHOULD BE AS TIGHT AS POSSIBLE USING HAND TOOLS. BARS MUST NOT TOUCH EACH OTHER. EVERY HOLE FROM TOP TO BOTTOM OF THE WALL/WALL BAR SYSTEM MUST HAVE A SECURELY TIGHTENED NUT AND BOLT. IF THIS IS DONE INCORRECTLY YOUR POOL WILL BREAK!

Type #2 Staggered Bolt Pattern

IMPORTANT - This operation must be done carefully! When joining the sidewall, make sure there are two strips. One must be installed on the inside of the pool (the head of the bolt will touch this bar) and the other on the outside of the pool (the 1/4 nuts will touch this bar). Please reference to the figures below. Insert the bolts with the bolt head to the inside and the nuts to the outside of the pool. Do not tighten until all bolts have been inserted. If your screwdriver slips and scratches the head of the bolt, file the scratch smooth so that it cannot puncture the liner. It is recommended that you cover the heads of the bolts, on the inside of the wall, with three layers of duct tape. If the insertion of the wall in the bottom rail is tight at the point where the wall is joined together, insert a screwdriver and twist to make enough room, again being sure not to scratch the wall or the bottom rail.

• If you are missing any hardware, do not leave empty holes in the wall joint assembly. Doing so will cause your pool to break!

See your pool dealer for additional hardware in the case of shortage.

STAGGERED BOLT WALL BAR SYSTEM

*** Every hole from top to bottom of wall/Wall bar system must have a securely tightened nut and bolt. ***

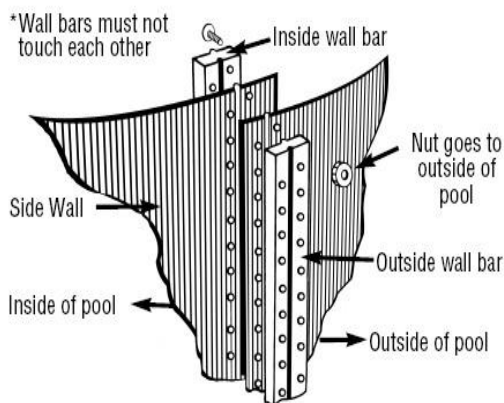

Top View

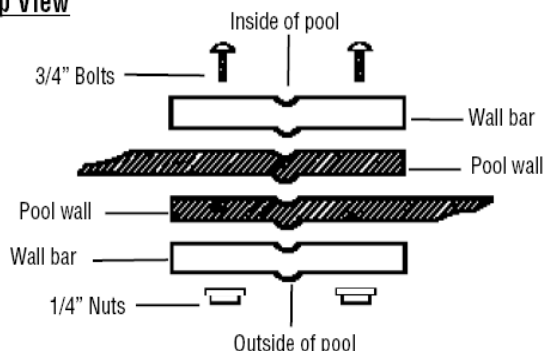

Fig. 48

REMEMBER:
ALL NUTS SHOULD BE AS TIGHT AS POSSIBLE USING HAND TOOLS. BARS MUST NOT TOUCH EACH OTHER. EVERY HOLE FROM TOP TO BOTTOM OF THE WALL/WALL BAR SYSTEM MUST HAVE A SECURELY TIGHTENED NUT AND BOLT. IF THIS IS DONE INCORRECTLY YOUR POOL WILL BREAK!

STEP 15: WALL JOINT ASSEMBLY (Cont.)

Many pool walls come with a Wall Saver Panel. The Wall Saver Panel is a separate piece of the pool wall that has the skimmer and return openings in it. The Wall Saver Panel is joined to the pool wall at each end. Your pool will have 2 wall joints. On many size pools and many Wall Saver Panels this means that one (1) of the joints will be exposed and clearly visible on the outside of the pool instead of being behind a pool upright. This is normal. See Fig.49 for how the wall saver panel is installed in the pool wall.

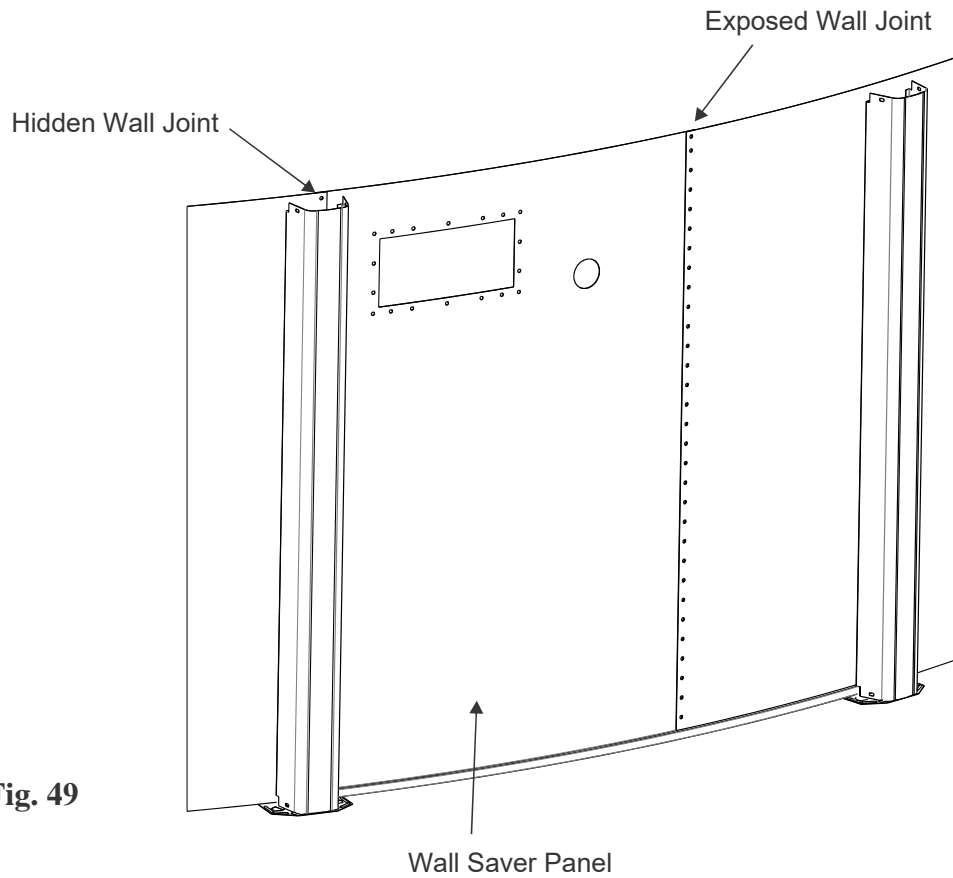

Fig. 49

STEP 16 – PREPARING THE COVE:

Build a sand cove against the pool wall by creating a 4" angle of sand (on top of the 3" sand base) giving you a total sand cove height of 7 inches where the base meets the metal pool wall (Fig.50). This will prevent the liner from creeping under the wall, and it will also protect the liner from any metal edges of the pool framework.

There should be no air space between the vinyl pool liner and the base the liner is resting on.

THIS STEP IS NOT OPTIONAL, IT MUST BE DONE.

Water the sand to compact it and use a trowel to spread it evenly. The cove is an important part of the pool structure. Take your time to make a complete, full-size cove.

Since earth containing chemicals can cause discoloration or corrosion, it is suggested that you place polyethylene plastic sheeting under the cove around the perimeter of the wall, so no earth comes in contact with the metal. Since the presence of such chemicals is beyond the control of the manufacturer, such damage is not covered under warranty.

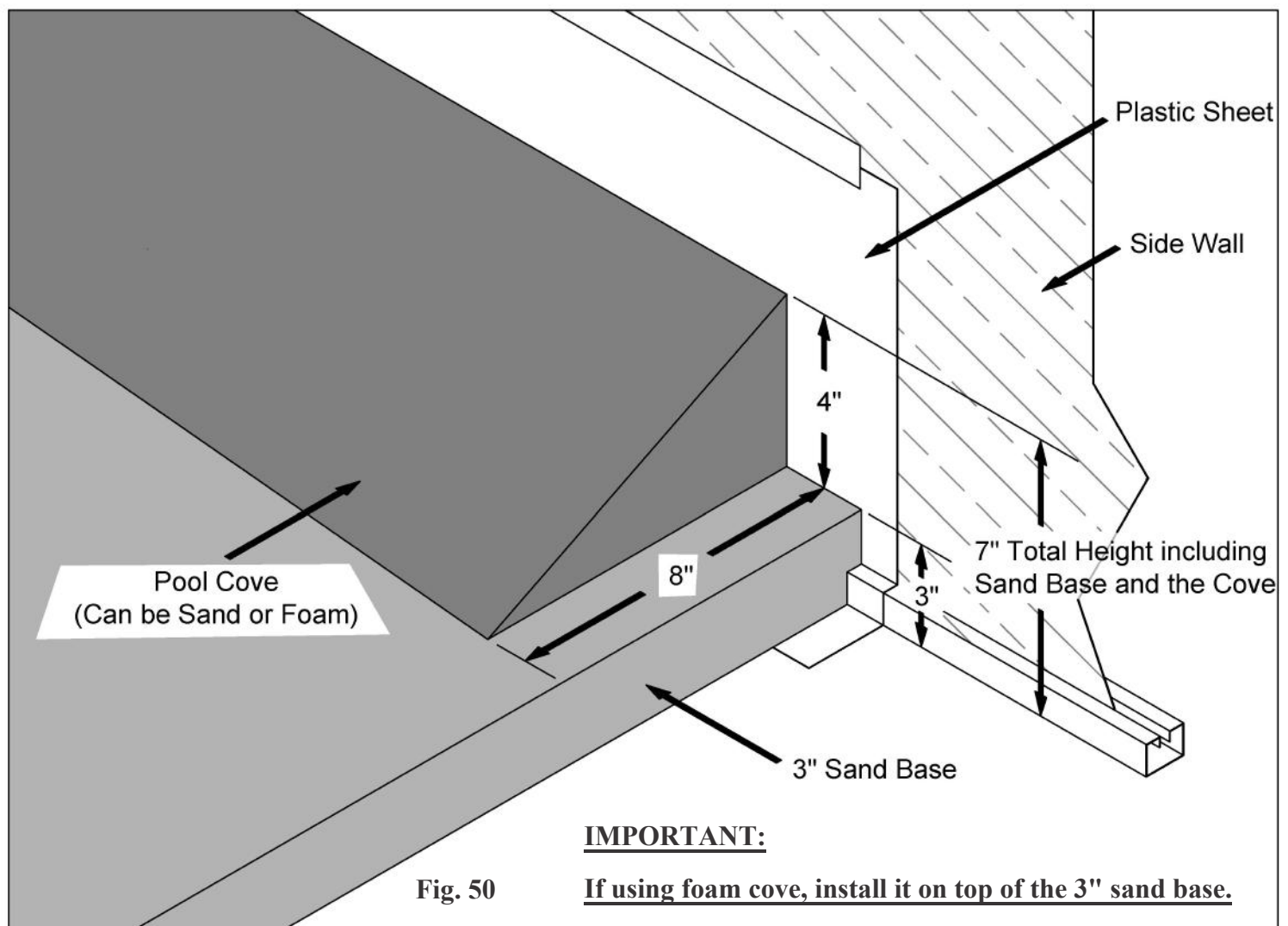

IMPORTANT NEXT STEP; Follow the liner manufacturer's instructions to install pool liner.



IMPORTANT INFORMATION ABOUT YOUR LINER

We do not make or supply liners for our pools.

Please contact your liner's manufacturer with questions or if instructions are not included with the liner.

Liner must be installed per the liner manufacturer's instructions.

Incorrect liner installation may void the warranty.

STEP 17 –CURVED END UPRIGHT ASSEMBLY:

It is easiest to line up all the uprights next to each other. It helps to lean them up against a fence or some other sturdy object. On most models the top of the uprights can be identified by either an extra hole in the middle, or by an extra hole on each side (depending on which pool you have) for the decorator caps. Place the metal top plate on the upright making sure the holes line up and the hooked part of the plate is facing the open end of the upright (the side that goes against the pool wall). Now put a #10 x 1/2" screw in the center hole only. (Fig.51). Do not install screws in the two side holes until later. This will make things easier and more efficient later down the line.

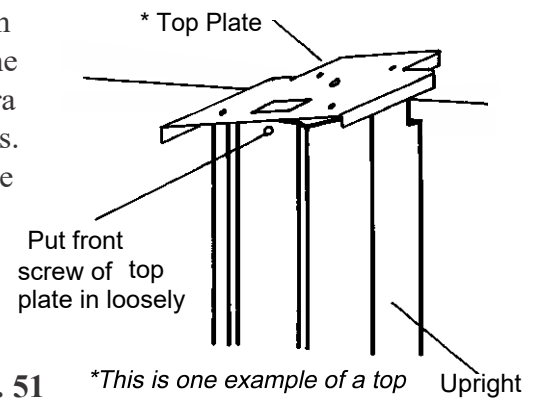

Fig. 51 **This is one example of a top plate. The plate for your pool may look a little different.*

TYPE#1 - BOTTOM PLATE POOLS:

- Models with metal or resin bottom plates will require one, two or three #10 x 1/2" screws for each upright depending on which model you have (Fig.52).
- The top plates can remain unsecured for now, but they should be temporarily clipped over the wall to prevent them from falling backward.
- If your pool has an additional resin "boot" for the upright, secure them to the uprights at this point using two more #10 x 1/2" screws.
- Check curved ends of the pool for roundness again, making sure that the stakes should have not been moved and your pool is still a true oval shape.

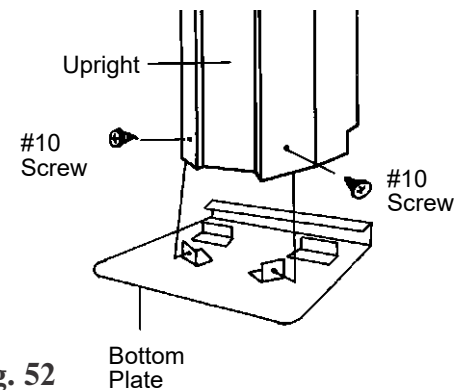

Fig. 52

TYPE#2 - BOTTOM FOOT COVER POOLS:

- Models with resin bottom foot covers instead of bottom plates, do not require hardware in order to secure the upright at the bottom. Simply line up holes in the lower portion of the upright with the corresponding clips in the bottom foot cover and push them down until they lock in place. (Fig.53). When this is done properly the upright will not be able to be pulled up without bringing the bottom foot cover with it.
- The metal top plates can remain unsecured for the time being, but they should be temporarily clipped over the wall to prevent them from falling backward.
- Check curved ends of the pool for roundness again, making sure that the stakes have not been moved and your pool is still a true oval shape.

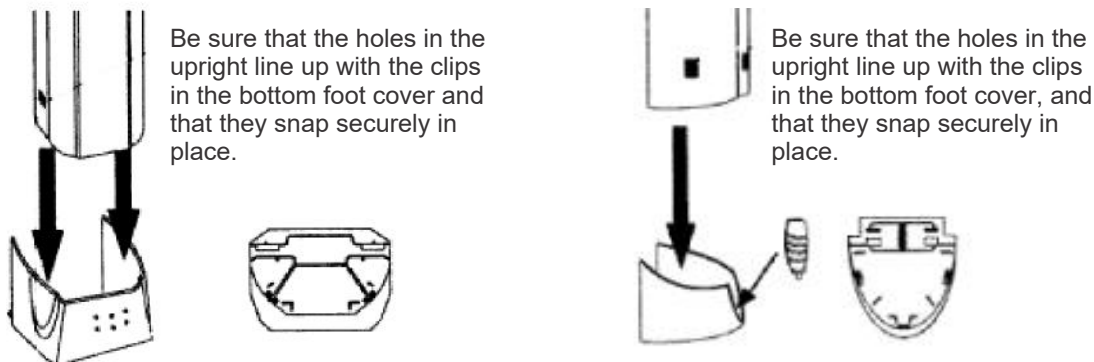

Fig. 53

STEP 17 –CURVED END UPRIGHT ASSEMBLY (Cont.)

ACCENT CLIP INSTALLATION (Not applicable to all models of pools):

Sort bottom foot cover and/or uprights have separate accent clips. This is a good time to snap those pieces on if your pool has these. Below are some examples of accent clips. (Fig.54 & Fig.55)

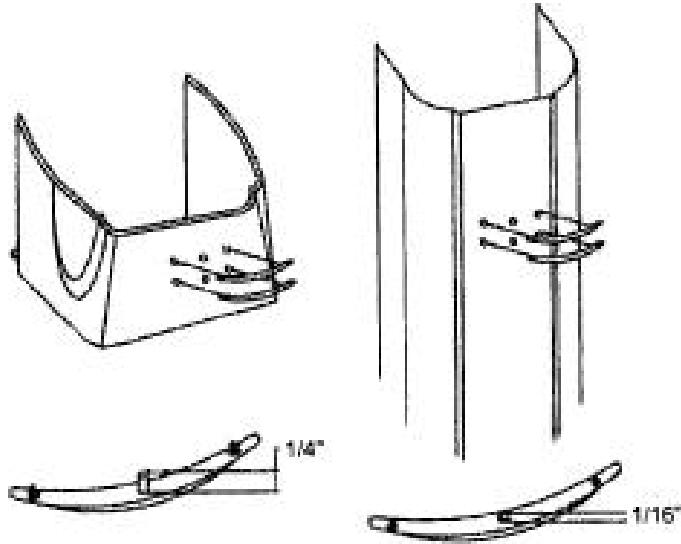

Fig. 54

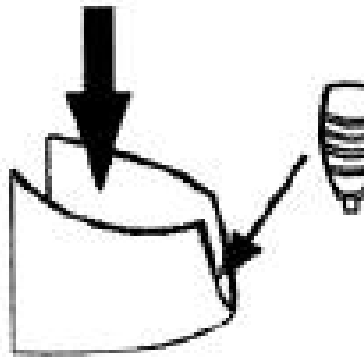
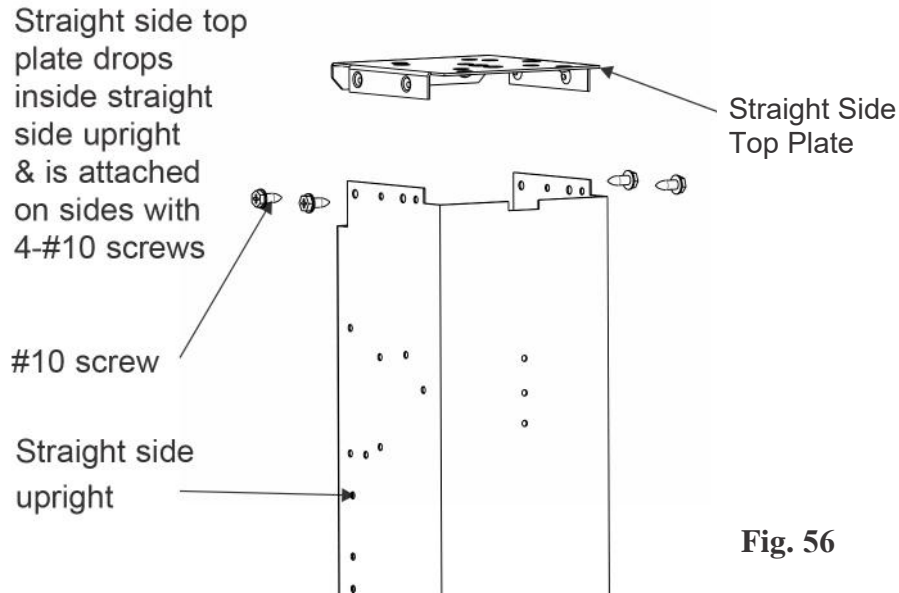

Fig. 55

STEP 18 – STRAIGHT SIDE TOP PLATE INSTALLATION:

Now is the time to install the straight side top plates. Simply place each one over a different oval upright and the stabilizer rail, match the holes on the top plate to those on the straight side upright, and fasten them together using four #10 x 1/2" screws in each. (Fig.56).



STEP 19 – SECURING THE CURVED SIDE UPRIGHTS:

For the uprights on the curved ends of the pool, you can now pull the front of the top plate (the hooked part) over the stabilizer bar and, after you are positive that the upright is level, you can now add the final two screws necessary to secure the uprights to the pool. If the uprights are not level, it will be very difficult to get the top rails to fit together. It is a good idea to use a carpenter's level to check that the upright is standing perfectly straight. If the upright is leaning left or right this is easy to correct before putting the final two screws into the top plate. (Fig.57).

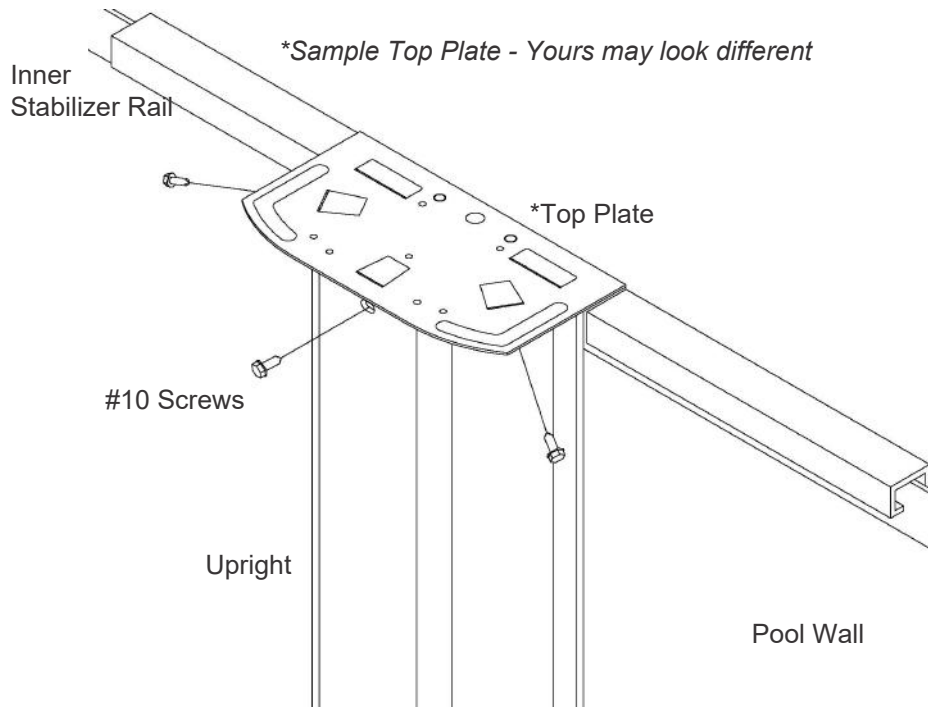

Fig. 57

STEP 20 – TOP RAIL INSTALLATION:

Your pool either has metal top rails, or resin top rails. Please notice the different hardware that is necessary for the resin top rail pools.

You should have two people while installing the top rails. If a top rail falls in the pool it can cut your liner.

- You should have two different length top rails with your oval pool. The 41 ¼" long top rails (measured from longest point to longest point) are for the straight sides of the pool. Note, the four rails that connect the curved side uprights to the straight side uprights are 41 ¼" rails.
- Install all straight side rails (41 ¼") first by placing them on the top plates, lining up the holes in the top rail with the holes in the top plates, and secure them down using four #10 screws for each top rail. All screws should be put on loose and tightened after all rails are on.
- Once all of the straight side rails are done, install the longer rails on the curved sides of the pool in the same fashion.

RESIN TOP RAIL INSTALLATION:

When a resin top rail pool is assembled, you must use special hardware to attach the resin top rail to the metal top plate. (Fig 60). The special hardware is a #10 x 1" screw with built in washer.

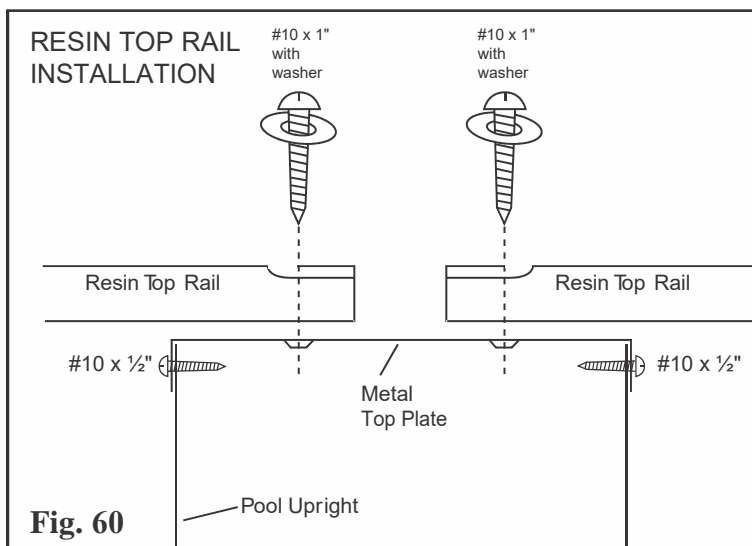

Traditional Buttress

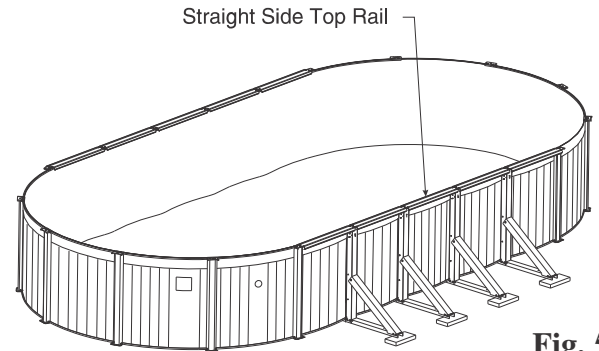

Buttress-Free

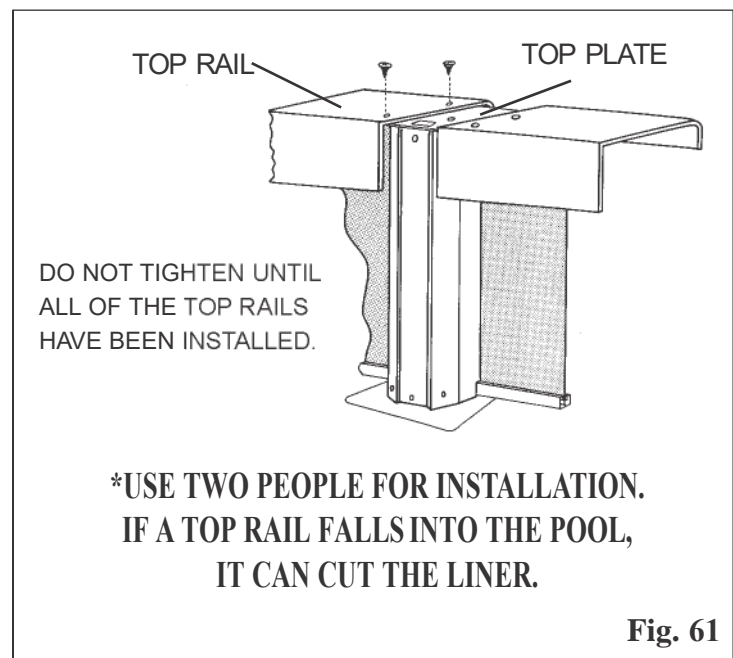
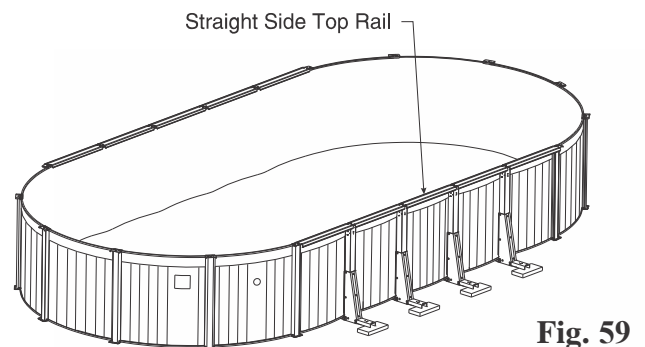

STEP 21 –TOP COVER INSTALLATION:

TWO PIECE RESIN TOP COVER WITH ATTACHMENTS ON THE SIDES There is a straight support with a square cutout to fit the oval upright, instead of an angle support supplied for the curved ends. It attaches the exact same way as the angle support.

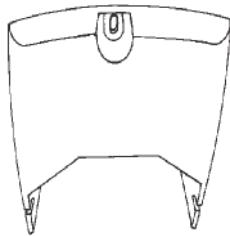

CURVED SIDE ANGLE SUPPORT:
Use on curved end upright.

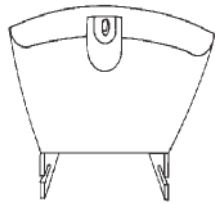

STRAIGHT SIDE SUPPORT
Used on the straight side of the pool-notice the square cutout. Use on oval uprights.

Fasten bottom half of top cap to upright using #10 screws.
Secure top half to bottom half using #12 screws.

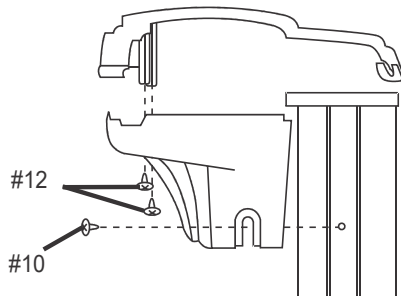

2 PC RESIN TOP COVER: Center small half over hole in the top plate as shown and attach with a #12 screw. Slide the large half over the small half and secure using two #10 screws.

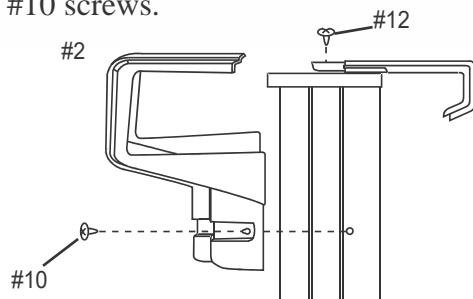

1) Attach the inner top cap using a #12 Screw into hole #2.

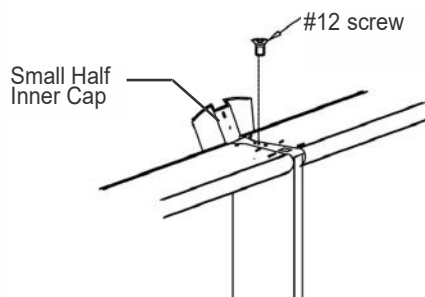

LARGE TWO PIECE RESIN TOP COVER WITH ATTACHMENT IN FRONT: (DOES NOT INCLUDE 6" TOP RAIL POOLS)
The curved end angle support is slightly larger than the straight support. The straight support is not filled in the back.

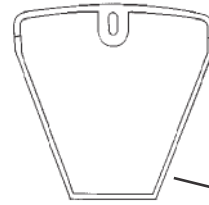

TOP VIEW OF CURVED SIDE ANGLE SUPPORT:
Larger than straight side support. Has back wall. Use on curved end uprights.

Back wall

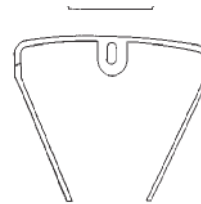

TOP VIEW OF STRAIGHT SIDE SUPPORT:
Smaller piece that is open in back. Use on oval uprights.

No back wall

ONE PIECE RESIN CLIP-ON COVER: This installation requires no hardware. Simply hook the back end of the top cover into place, and use your fingers or a screwdriver to gently flex the front tabs enough to hook the cover in place. Make sure that the top cover is centered over the upright when installing.

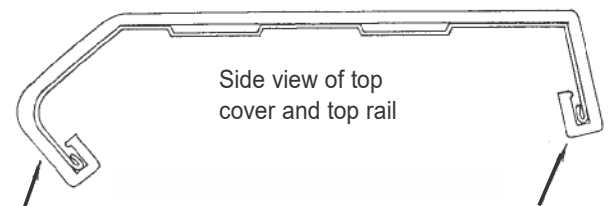

Side view of top cover and top rail

Swing this end around and gently flex tab into place.

Hook this end first.

Bullnose rail is used for the illustration, but installation is the same for all 1 pc. clip-on resin covers.

2) Attach the resin outer Top Cap using a #12 screw into hole. Put the grill over the screw when finished. See Diagram below.

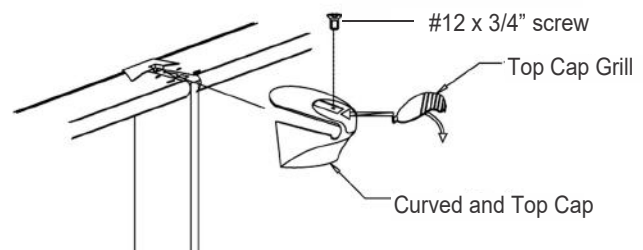

POOL INSPECTION

READ AND FOLLOW ALL INSTRUCTIONS

Keep your pool wall and frame clean. Always wash away any deposits of pool chemicals which land on the frame of your pool. Wash periodically with a mild soap solution (no abrasives). At least once a year use a clear non-yellowing household wax on all metal components.

Your pool and liner must be inspected regularly for leaks, corrosion, scratches, and punctures. If any problem is found IMMEDIATE CORRECTIVE ACTION MUST BE TAKEN. Small repairs and punctures in your liner may be easily repaired using repair kits available at your local dealer. Scratches on your pool wall and frame must be touched up with anti-rust enamel. Wire brush all rust and add a coat of enamel primer followed by a coat of color matching paint. Pool water is full of various caustic chemicals, which will corrode metal parts. If any corrosion is allowed to continue, failure of the pool structure may occur which could result in excessive property damage as well as bodily harm.

The skimmer, return area and below them, are particular areas that must be carefully and regularly inspected. If these areas are wet, and remain wet for any length of time, it usually means there is a small leak. Skimmer/skimmer return gaskets must be replaced when they become defective. Water must not be permitted to continually run down the wall, if neglected, the pool will break. If proper skimmer/skimmer return gasket care is not maintained, your warranty will be void!

IMPORTANT

Be sure to follow all local and state safety regulations when installing any accessory to your pool. Any decks, and all entries, must be carefully monitored for safety and access to pool. Please follow the manufacturer's guidelines for your safety.

WINTERIZING YOUR POOL

Along with the cool nights of autumn comes the end of the swimming season. During the winter your pool is subject to more stress than in the summer, and any breakage that is caused by incorrect winter procedures is not subject to any warranty with this company.

All of our pools are designed to be left up all winter, but nonetheless are subject to the warranty that was purchased. Continue to chlorinate and filter until the pool is closed down. If you follow our recommendations, you will be able to winterize your pool properly in a few hours.

Properly winterizing your pool will protect it from damages and make it easier for you to reopen it when spring arrives.

The key to fast and easy winterization lies in regular treatment of the water until the start of the cold season, even if you haven't been using the pool.

Routine maintenance becomes easier and less frequent as the water gets cooler. In order to keep the water clean and clear and to prevent the liner from staining, we recommend closing your pool as late as possible, i.e. toward the end of September when the water temperature is about 10°C (50°F).

Waiting until you have finished closing the pool before shutting off the filtration system will prevent hoses still connected from freezing.

Follow the instructions on the following pages or contact your retailer for further information to ensure that you are protecting your pool properly.

CLOSING YOUR POOL FOR WINTER

At the end of the season, you must follow these directions to make your pool ready for the winter. For areas where water freezes make sure to follow these instructions before the water is frozen, otherwise do not touch the frozen water, this may damage the pool.

STEP 1

PRIOR TO CLOSING

Several days prior to closing your pool, test the water for the pH level, total alkalinity, and chlorine. The water balance is important to protect the pool from corrosion or scale build-up during winter shut down.

STEP 2

PERFORM A COMPLETE INSPECTION

FINDING LEAKS

Towards the end of the summer season, check for leaks by verifying if the pool's water level is stable. Draw a line on the liner marking the water level and wait 10 days. If after 10 days the level has dropped, then there is a leak. It is important to seal off any leaks you find. Leaks left unsealed when freezing begins can seriously damage your pool and even cause it to collapse.

Vacuum carefully to remove all leaves and debris.

CHECK THE LINER

Make sure the top of the liner is still attached to the pool wall. Make sure there are no leaks. Repair any liner holes with a vinyl patch: any small punctures in the liner can be easily repaired with underwater repair kits available at your local retailer. Do not remove the liner from the pool, as removal of the liner will void the existing warranty.

CHECK ALL JOINTS AND SCREWS

Make sure all the frame joints are fitting together properly and make sure the pool wall has not shifted from the bottom rail. Ensure all screws and bolts are tight.

CHECK FOR RUST

Periodically inspect the metal parts for any corrosion especially around the skimmer area. If corrosion is found, immediate corrective action must be taken. Wire brush any rust and add a coat of enamel primer followed by a coat of color matching anti-rust enamel paint. Pool structure failure could result in major property damage and bodily harm. Paint any scratches with anti-rust paint.

STEP 3

ADD CLOSING CHEMICALS

To maintain water quality, use a winter kit which contains an algicide and chlorine especially designed for this purpose. When it's time for spring cleaning, this will save you hours of work and reduce the cost of chemicals needed to restore your water quality.

If your pool has a bottom drain, you will have to use pool antifreeze to prevent it from freezing during the winter. Unscrew the hose from the base of the skimmer and attach an extension. Pass the extension over the wall of the pool, making sure it remains well attached. Pour antifreeze into the extension. Leave the valve open so that water can drain from the skimmer.

STEP 4

LOWER THE WATER LEVEL

Lower the water level so as to leave between 6 to 20 inches (15cm to 50cm) below the water return. You may plug the return jet hole at this time. ****IMPORTANT**DO NOT PLUG THE SKIMMER DRAIN HOLE** (located at the base of the skimmer). Remove all hoses attached to the skimmer and return fittings. Do not let water freeze in the skimmer. Leave the skimmer attached to the pool wall and ensure that the skimmer lid is installed. **DO NOT DRAIN ALL THE WATER OUT OF THE POOL.**

Depending on your area and if the freezing point is more aggressive, for example 50% is frozen into ice, we strongly suggest to lowering the water to lowest point. Depending on how great the deep freeze is in your area we suggest you consult with your local dealer about procedures on lowering the water level throughout the winter. We also suggest throughout the autumn season to continually check this level before freezing season starts, as it must not reach the skimmer holes at any time during the winter. Remove any snow which may accumulate on the top ledges.

STEP 5

FILTRATION PREPARATION

Disconnect the hoses from the filter. Remove and store the filter, ladder and all other removable parts from around the pool. The filter should be clear of any foreign objects and water should be removed from the filter and pump. See the manufacturer's instructions. Store the pump in a temperature controlled environment (so that it is not damaged by changes in temperature).

STEP 6

WINTER COVER

For the winter cover we suggest to lower the water level to 1 inch (2.5cm) below the water return. In some areas your dealer may ask you to install it differently in order to protect the pool and the cover. Contact your local dealer to verify the correct procedure for your pool.

If using a winter cover, make sure to place a ball underneath so that rainwater falls into the pool. An accumulation of too much water on the cover could place pressure on the pool, causing damage and invalidating the warranty. Depending on how great the deep freeze is in your area we suggest you consult with your local dealer about procedures on leaving the pool cover throughout the winter.

IMPORTANT

Never let more than 30 cm (1') of snow accumulate on the pool wall; the wall is designed to support the lateral pressure of the pool water, not vertical pressure. With spring thaw, if water leaks from the skimmer or return outlet opening, place a tube at the opening so that the water will run off as far away from the basin of the pool as possible. **PLEASE NOTE:** Do not strike or hit a frozen pool. This would damage it. Do not disturb the pool till spring. If you have left the winter cover on the pool, make sure to remove accumulated snow after heavy snowfalls.

IMPORTANT

Whatever the type of valve or extension hose used, you must follow the technique described in this document to close your pool, otherwise your warranty may be cancelled. Make sure to use antifreeze designed for pools.

An unsealed leak may comprise or cancel the warranty on your pool. Never leave water in any of the filtration system components due to the risk of damage during freezing.

PREPARING YOUR POOL IN SPRING

READ ALL INSTRUCTIONS CAREFULLY

At the end of winter, allow the ice in the pool to thaw completely. When the temperature reaches approximately 10 °C (50 °F), you have to restart your filtration system, since algae and bacterial form more quickly as it gets warmer. Here is how to prepare your pool in a few simple easy steps.

STEP 1

If your pool is equipped with a pool cover, remove the cover and ball. Carefully remove with a hose any rainwater that has accumulated on the cover so it does not fall into your pool. Clean your cover and ball and let them dry. Store them in a dry clean place.

STEP 2

Attach the return inlet and skimmer to the filter. Bring the water level up to the middle of the skimmer. Get your filter working. Clean the bottom of the pool with the vacuum, taking care to place the filter in the "waste/drain" position. This way you will eliminate particles of dirt without disturbing the sand in the filter, and will considerably reduce the need for "backwash rinsing" of the filter.

STEP 3

Now that you have purified the water, you have to test it. It is very important that the pH level of your pool is between 7.6 and 7.8 and the pool's alkaline content is between 80 ppm and 130 ppm. If you are unable to attain these levels, please contact your retailer who will gladly do these tests for you.

STEP 4

When the pH and alkaline levels are ideal, apply a shock-treatment or chlorinate your water.

Let it filter for 24 hours and again verify both the pH and free chlorine levels. **NOTE:** Add chemical products to your pool after sunset, as sunlight rapidly destroys chlorine.

STEP 5

Let it filter for several days until the water is clear and the pH and free chlorine levels have stabilized. Add a conditioner/stabilizer by carefully following the manufacturer's instructions. This will stop the chlorine from evaporating quickly in sunlight. Add the quantity of algicide required to prevent algae.

STEP 6

You may now begin regular maintenance of your pool. Don't forget to obtain a new set of solutions for your water analysis kit every spring. The old solutions may give false results.

STEP 7

Make sure that the skimmer (screws and adapter) is properly in place and tighten the water return fittings to prevent leakage and premature rusting of the pool wall or the lower part of the bottom rail.

IMPORTANT

Do not drain your pool to clean the water unless absolutely necessary (the water is recyclable). If you do empty your pool, don't leave it empty for too long or expose it to direct sunlight, as the liner may shrink.

IF YOU FOLLOW THESE TIPS AND ASK YOUR DEALER FOR ANY OTHER ADVICE YOU MAY NEED, YOU WILL HAVE ALL THE INFORMATION NECESSARY TO GET YOUR POOL OPERATING AGAIN.

WARRANTY REGISTRATION

INSCRIPTION GARANTIE

For your protection as a pool owner, it is important for Wilbar to keep a record of your purchase. Please place the enclosed Safety Labels on your pool per our directions. This will ensure the validity of your warranty, and the use of safety labels may protect you against possible legal liability in case of serious injury.

Please take a few moments to fill out the form below and mail, fax, or scan and send via email. Be sure to retain a copy of the completed form for your records, in case you require warranted repairs or need another set of free Pool Safety Labels.

Pour votre protection en tant que propriétaire de piscine, il est important que Wilbar conserve une trace de votre achat. Veuillez placer les étiquettes de sécurité ci-jointes sur votre piscine conformément à nos instructions. Cela garantira la validité de votre garantie et l'utilisation d'étiquettes de sécurité pourrait vous protéger contre une éventuelle responsabilité légale en cas de blessure grave.

Veillez prendre quelques instants pour remplir le formulaire ci-dessous et nous l'envoyer par courrier, fax ou numérisation et l'envoyer par courrier électronique. Assurez-vous de conserver et de conserver une copie du formulaire rempli pour vos dossiers, au cas où vous auriez besoin de réparations sous garantie ou si vous avez besoin d'un autre jeu d'étiquettes de sécurité pour piscine gratuites

Factory Registered Warranty Form. Liner warranty supplied by dealer.

I have placed all three (3) Pool Safety Labels on my pool in the locations suggested in your instructions. Please register the warranty at mypoolwarranty.com.

Formulaire de garantie enregistré. Garantie pour la toile est fourni par le détaillant.

J'ai placé les trois (3) étiquettes de sécurité sur ma piscine dans les endroit que vous avez suggéré dans vos instructions. S'il vous plaît inscrivez-vous la garantie au mypoolwarranty.com

Name/Nom: _____

Address/Adresse: _____

City/Ville: _____ State/Prov.: _____ Zip/C.P.: _____

Pool dealer/Détaillant: _____

Model purchased/Modèle de piscine: _____

Date of Purchase/Date de l'achat: _____

Mail to/Envoyer par la poste:

Or fax to/Par télécopie:

Or email/Courriel:

Wilbar Group
50 Cabot Court
Hauppauge, NY 11788
ATTN:
WARRANTY/GARANTIE

(631) 951-9170

info@mypoolwarranty.com