

BILTMOR DECK 5005

Contents of the Biltmor box SKU # 5005

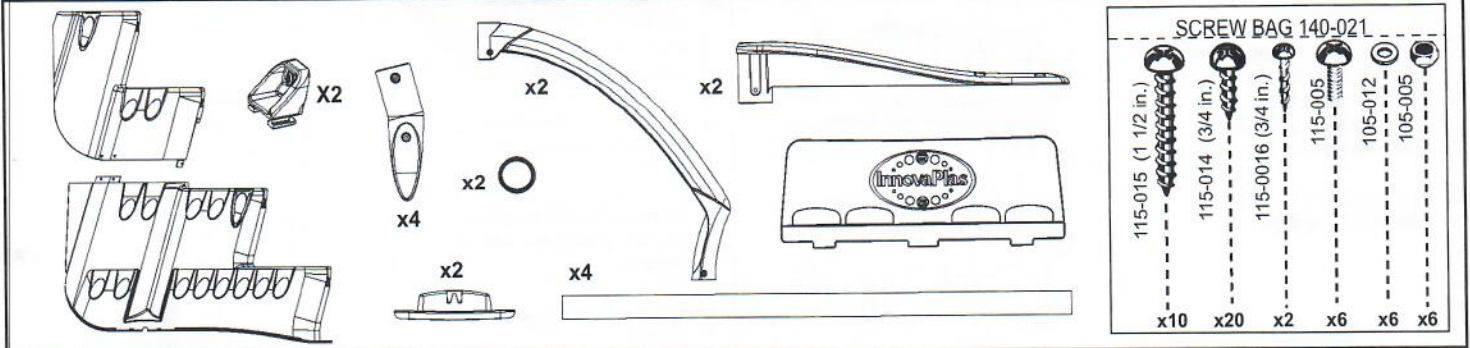

⚠ WARNING

- ◆ Do not dive or jump from step or ladder.
- ◆ Use BATTERY operated tools to avoid electric shocks.
- ◆ Install step on flat surface, following the manufacturers instructions.
- ◆ Remove step from pool during freezing climate season.
- ◆ Manufacturer cannot be held responsible for injuries caused by abusive use of product.
- ◆ Ask your city about specific regulations that apply to your above-ground pool and ladder.

Tools required (not included)

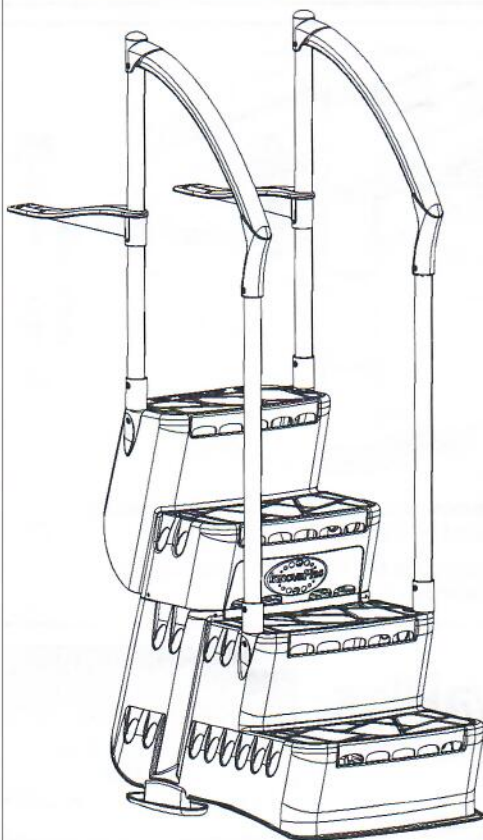
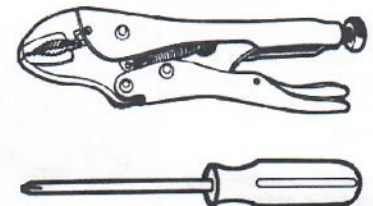

A

- 1) Insert the 2 gussets in the slots and slide them toward the corners.
- 2) Assemble the two main modules with the six screws, nuts and washers provided.
- 3) Snap the door between the top and bottom module within the slots provided.
- 4) Fasten the access panel with the screws provided.

115-0016 (3/4 in.)
x2

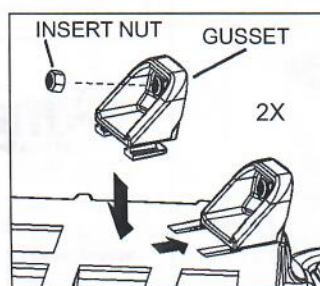

115-006 x6
105-012 x6
105-005 x6

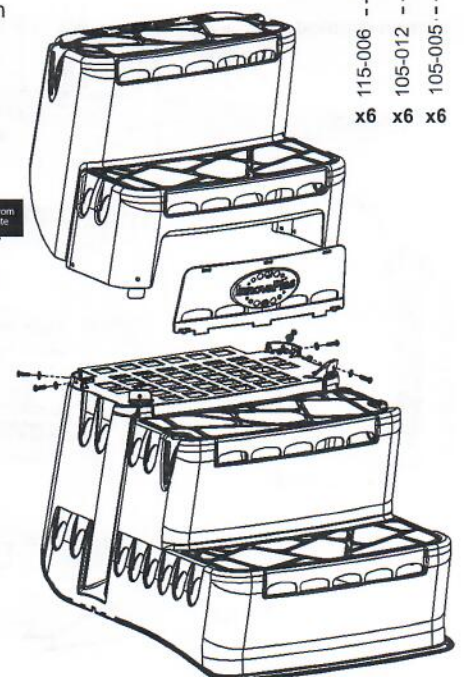

B

- 1) Snap the four post ends into the step, making sure that the cylindrical part is vertical and that the ends are snapped properly in their respective housings.
- 2) Snap the 2 feet to the bottom of the step.

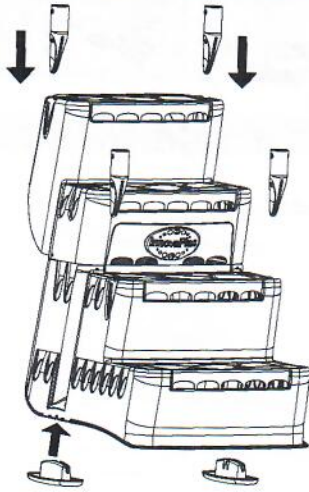

C

- 1) Insert the four posts into the post ends and secure them in place with the screws provided.
- 2) Insert the two deck supports over the rear posts.
- 3) Insert the handrails on the four posts and secure in place.
- 4) Install the small post covers.

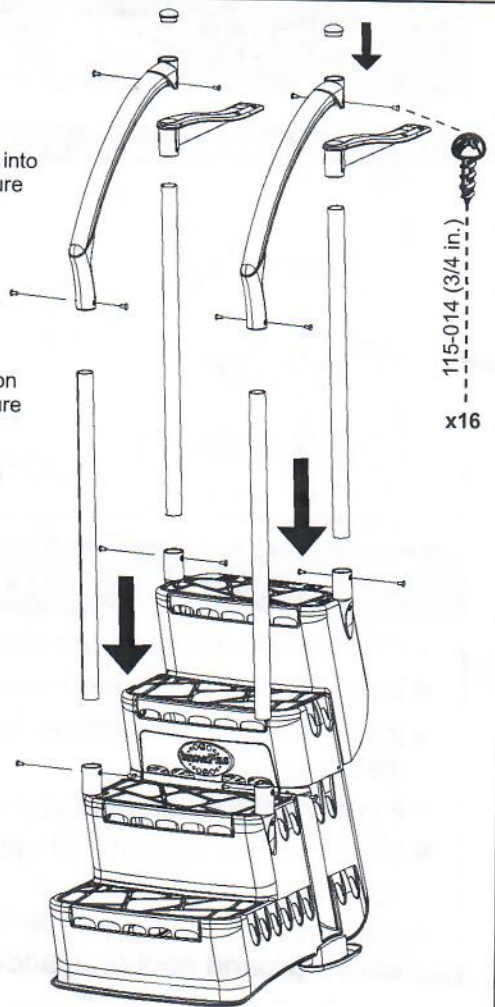

D

- 1) Slowly submerge the step into the pool. Make sure you do not damage the pool liner in the process.
- 2) Angle the whole step so that it is entirely under water. This will purge all the air from under the steps.

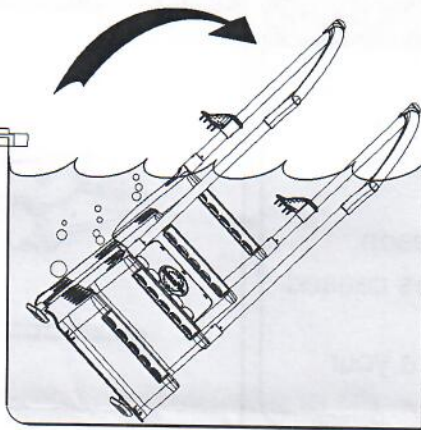

E

- 1) Affix the deck supports with the screws supplied.

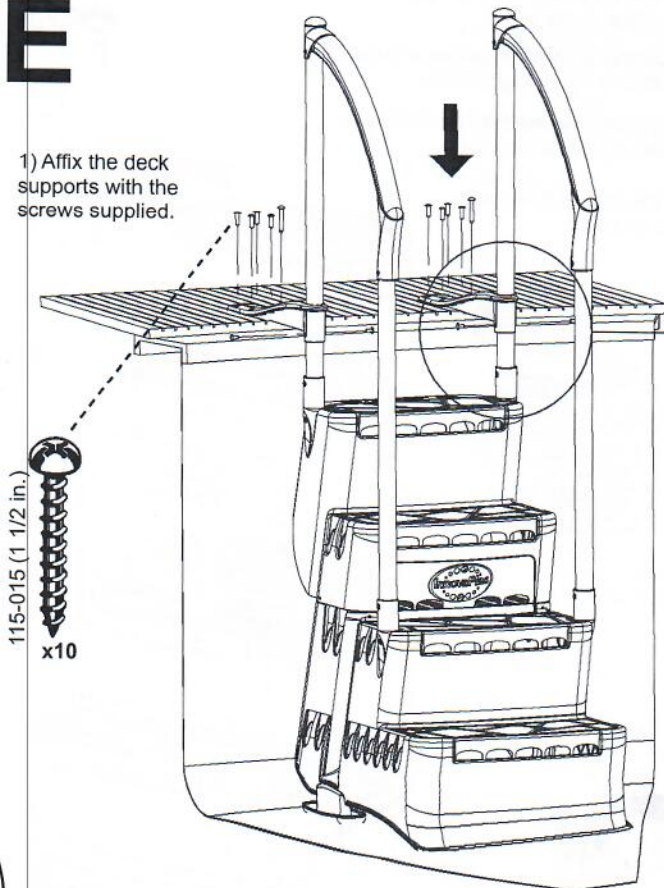

F

- 1) Pull the deck supports (already fixed to the deck) upwards to create a spring effect on the step.
- 2) Fasten the supports to the two rear posts while pushing the entire step downwards.

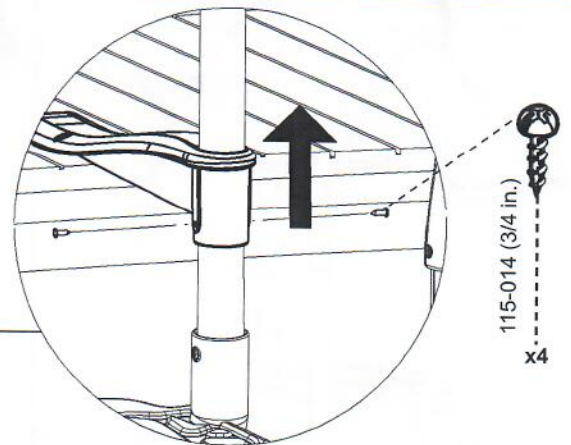

InnovaPlas
The Pool Step Company

2257, Route 139
Drummondville, Qc.,
Canada J2A 2G2
WWW.INNOVAPLAS.COM

REV. 2016-02-03
PN : 110-006

**MANUFACTURER
WARRANTY**

1 year on the
Biltmor.
1 year on the hardware.

