



User Guide

Model: EJ-HF035
Inflatable Top Ring Swimming Pool

IMPORTANT SAFETY INSTRUCTIONS

READ AND FOLLOW ALL SAFETY INFORMATION AND INSTRUCTIONS. KEEP FOR FUTURE REFERENCE. FAILURE TO FOLLOW THESE WARNINGS AND INSTRUCTIONS CAN RESULT IN SERIOUS INJURY OR DEATH TO USERS, ESPECIALLY CHILDREN.

This manual addresses some common risks but not all danger of water recreation. Always be cautious, use common sense and wise judgment when enjoying water activity.

WARNING!

PREVENT DROWNING



Children-especially toddlers are at high risk of drowning. Close supervision is necessary when children are in or near the pool. Never leave your children unattended.

NO DIVING OR JUMPING SHALLOW WATER



Diving or jumping may result in broken neck, paralysis, permanent injury or death.



Intended for use of people aged 6 and above.

ON FLAT, LEVEL, COMPACT GROUND



Failure to set up pool on flat, level, compact ground or over filling could result in collapse of the pool.

Safety for Young Children

- Check state or local laws and codes before setting up the pool. Drowning occurs silently and quickly. Assign an adult to supervise the pool and wear provided water watcher tag.
- Children can be drowned in a very small amount of water. Empty pool or prevent access when not in use. Store the empty pool so that it does not collect water from rain or any other source.
- Keep children under direct sight. Actively supervise them when they are in or near the pool or when you are filling or emptying the pool. When searching for a missing child, check the pool first, even if he/she is thought to be in the house.
- Set up a fence or other approved barriers around the pool according to the local law and regulations to avoid unsupervised children accessing the pool.
- Remove the pool ladders before leaving the pool. Toddlers can climb the ladder and get into the pool.
- Position furniture away from the pool so that children cannot climb and gain access to the pool.
- Remove all toys or other items from the pool when not in use to avoid attracting children entering it.

Safety for Weak Swimmer or Non-swimmers

- Close and active supervision is needed for weak swimmers or non-swimmers by competent adults.
- Always assign a competent adult for supervision during each use.
- Weak swimmers or non-swimmers should always wear life saving device when using the pool.

Necessary Safety Appliance

- It is recommended to install a barrier around the pool and secure all doors and windows near the pool to avoid unauthorized access to the pool.
- Keep a working phone and a list of emergency numbers near the pool.
- Never substitute adult supervision with safety devices like personal lifesaving devices, barriers, pool covers or warning signs.

Safe Use of the Pool

- Learn Lifesaving knowledge (e.g. Cardiopulmonary Resuscitation - CPR) and update it regularly, which will make a tremendous difference during emergency.
- Instruct all users including children on how to handle emergencies.
- Do not use after drinking or during medication. Please remove any cover completely before use if you have covered the pool.
- Change water in the pool regularly to prevent water-borne illness.
Do not add any undiluted chemicals into the pool to avoid injury to human.

- If any chemicals are occasionally used to reduce the frequency of water replacement, follow instructions from the manufacturer closely and dilute the chemicals properly. Keep the chemicals out of reach of children.
- Use of accessories not recommended by the manufacturer may lead to injury or property loss.
- Keep power cable, radio, speaker or any other electric appliances away from the pool. Never place the pool near or under the electric lines.
- Make sure installation and use of power appliances near the pool conform to local regulations.
- Assembly and disassembly of the pool and its accessories can only be conducted by adult. No tools are needed during the installation.
- Use the pool on an even and stable surface only. Keep it at least 2 meters / 6.56 feet away from buildings or any other obstructions.
- Leave enough space around the pool for adults to walk through for supervision of children inside the pool.
- Never lean over or squeeze the inflation or deflation valve to avoid injury or water overflow
- Take off all sharp objects (e.g. jewelry, watch, key) before entering the pool.
- Keep water inside the pool clean to avoid possible illness.
- Please clean and maintain the product properly to avoid fast wear abrasion and aging.
- Check the pool regularly for any sharp edges to avoid injury to human body
- Always read and follow warnings and safety signs on the pool.
- Only for domestic use. Only for outdoor use.

DO NOT drag the deflated pool on the ground

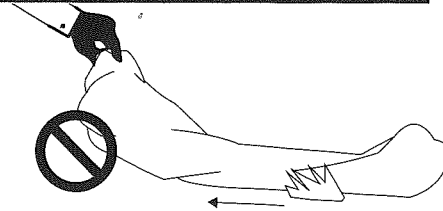

ⓘ SAVE THESE INSTRUCTIONS

To keep children from entering the pool area unaccompanied by a supervising adult, we suggest construct and maintain barriers, never leave children around a portable pool unsupervised. The Pool should be fenced, covered, or emptied and stored away when not in use. Recommendations as described in CPSC Pub. No. 362 found at www.poolsafely.gov.

Knowing Your Swimming Pool

Unpack and check that all accessories are inside.

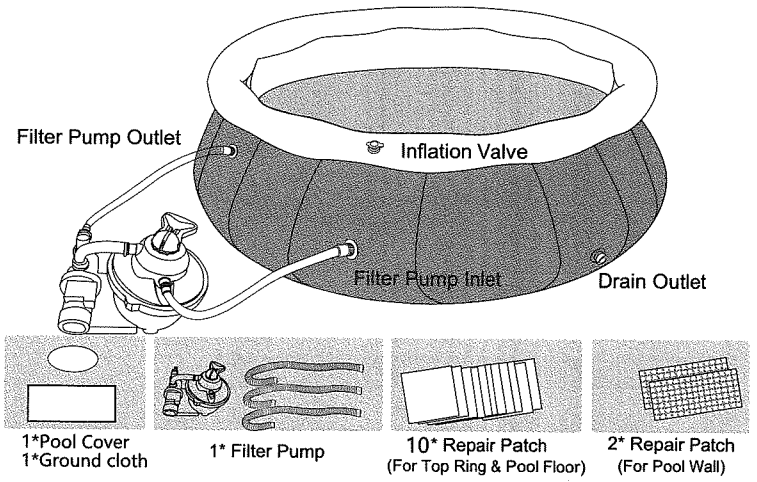

Getting Started

1. Lay out the pool on a level ground.
2. Inflate the top ring.
3. Fill the pool with water and enjoy.

Spreading Out the Pool

Spread out the pool on a flat, level ground free of any sharp objects. Make the pool floor as smooth as possible.

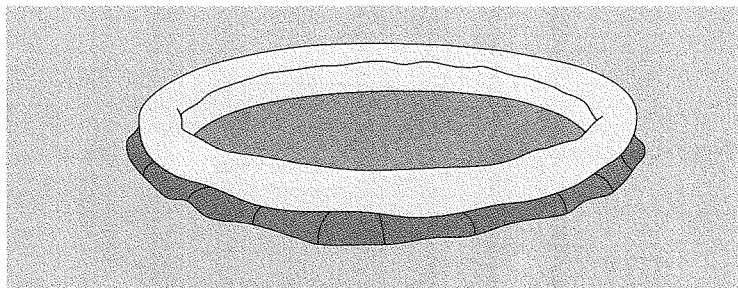

Inflating the Top Ring (air pump not included)

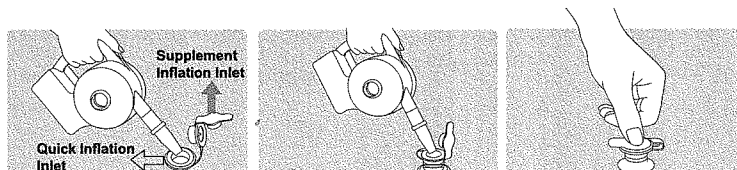

1. Inflate from the quick inflation inlet (bottom valve) first with the proper air pump nozzle(not included) until it is firm and solid.
2. Cap the quick inflation inlet, and then completely inflate from the supplement inflation inlet (top valve).
3. Once completed, insert the air valve plug to seal it. Do not overinflate.

Filling the Pool

1. Close all the covers of the inlet and outlet, close the Drain Outlet. Make sure that the drain plug's inner valve is sealed and the outer drain cap is screwed on tightly.

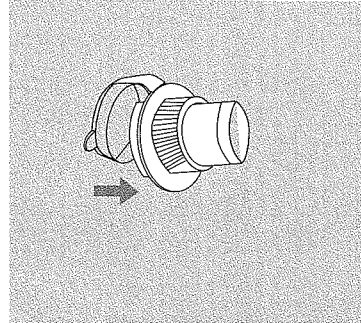

Inlet and outlet with cover

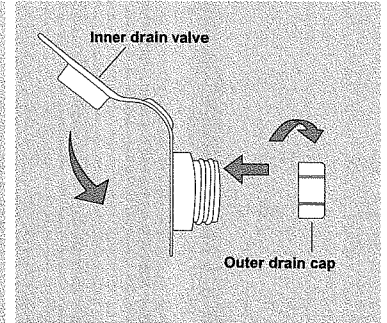

Drain Outlet

2. Smooth out the bottom wrinkles (from inside the pool) by pushing out where the pool floor and pool sides meet.

3. Now fill the pool with water. The pool wall will rise while you are filling it. Do not fill above the maximum filling indication.

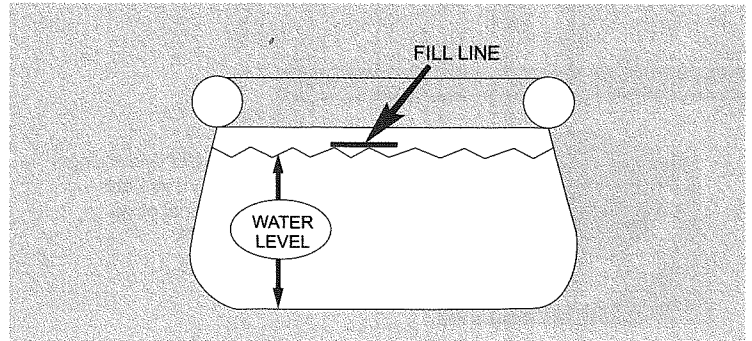

Using with Filter Pump (included in package)

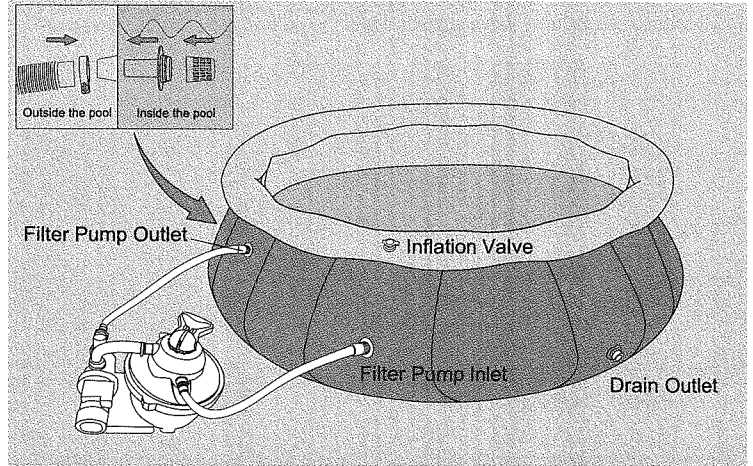

If your swimming pool comes with the Filter Pump, check Filter Pump User Manual for more information.

Using the Pool Cover and the ground cloth

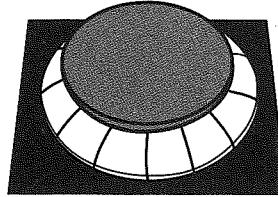

For a warmer water and a longer swimming season, you are provided with a pool cover and a ground cloth.

Repairing Leaks on Top Ring & Pool Floor

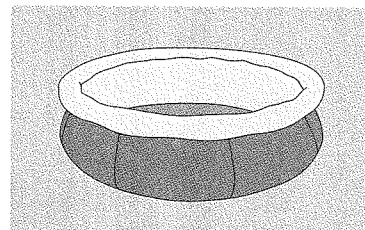
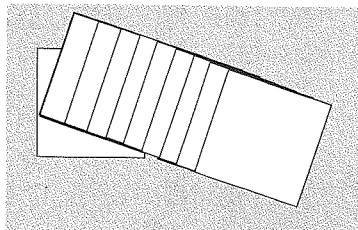

1. Locate the leak. Wipe clean and dry.
2. Cut a suitable size of repair patch (for PVC surface only) Attach over the leak.
3. Wait for 1 hour before re-inflating.

Repairing Leaks on Pool Wall

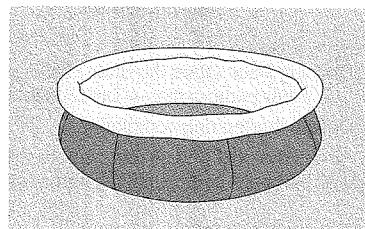
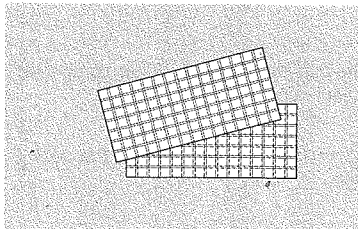

Draining the pool completely:

1. Locate the leak. Wipe clean and dry.
2. Cut a suitable size of patch.
3. Apply PVC glue (not included) to the plain side.
4. Apply PVC glue to the leak on pool wall, wait for 1 minute.
5. Attach over the leak and hold for 3 minutes.
6. Wait for 48 hours before using it again.

Storage and Maintenance

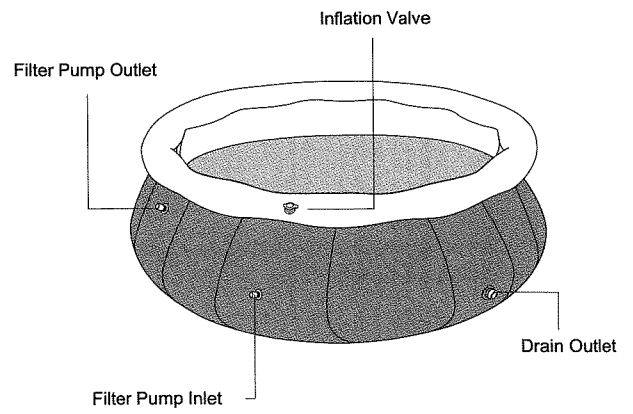

1. Draining Pool: Open the drain valves on the outside pool wall. (Filter pump inlet → Filter pump outlet → Drain outlet in sequence)
2. Deflate the top ring completely.
3. Air-dry the pool and all parts before folding and storage. Be sure that the pool and all parts are completely dry before storage.

Folding the Pool

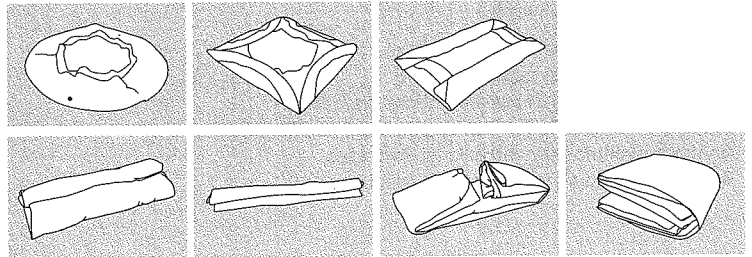



Email:
support@evajoy.co

Manufacturer:
Shenzhen Danya Technology Co.,Ltd.

Address:
Room 3323, Building C, Galaxy World Phase II, Minle Community,
Minzhi Street, Longhua District, Shenzhen, China
Made in China

