

# This manual must be left with the pool owner

Channel-Lok 1 Oval Pools  
□ Part No. 1920586 rev. 0

## SECTION 1

## Pool Component Installation Manual

# General Instructions



## Safety Rules For Pool Owners



Your pool contains a large quantity of water, and is deep enough to present inherent dangers to life and health unless the following safety rules are strictly observed. First-time users run the highest risk of injury. Make sure everyone understands all safety rules before entering the pool. Post **NO DIVING** and **NO JUMPING** signs beside the pool. For additional safety information please read the enclosed booklet *The Sensible Way To Enjoy Your Aboveground/Onground Swimming Pool*.



### 1. No Jumping or Diving

The top rail of your pool is not a walkway and must not be used for jumping or diving. Do not permit jumping or diving into the pool from a deck or the top rail of the pool. Diving or jumping into the pool can result in serious injury.



### 2. Never use the Pool Alone

Never permit the pool to be used unless it is attended by at least one person other than the bather. Someone should always be available to lend assistance in an emergency.



### 3. Never Leave Children Unattended

Never leave a child alone and unsupervised in or near the pool—not even for a second. There is no substitute for constant adult supervision.



### 4. No "Rough-housing"

Do not permit "rough-housing" in and around your pool. Surfaces can become slippery and hazardous when wet.



### 5. Light the Pool at Night

If the pool is used after dusk, adequate lighting must be provided. Illumination in the pool area must be sufficient to clearly judge pool depth and all features in and around the pool. For lighting recommendations, consult your local licensed electrical contractor.



### 6. Restrict Access to the Pool

Do not leave chairs or other furniture beside the pool that could be used by a child to climb up into the pool. Ladders must be removed whenever the pool is unattended. A fence with a lockable gate around the pool or yard is strongly recommended and may be required by law in some jurisdictions.



### 7. No Alcohol or Drugs

The use of alcohol or drugs does not mix with pool activities. Persons who have been drinking alcohol or using any drugs should not be allowed in the pool, and should be carefully supervised in the surrounding area.



### 8. Keep Your Pool Clean and Sanitary

Your filter system will remove suspended particles from the water and the surface skimmer will remove insects, leaves and other debris from the water surface. Use the correct pool chemicals as directed to destroy harmful bacteria and prevent formation of algae. Remember, unsanitary water is a serious health hazard.



# A. Introduction to Installing your Pool

**Read all instructions completely before you begin.**

These instructions explain how to install your pool. Simply follow the step-by-step directions. Start with this part, **SECTION 1** and use the other instructions, **SECTION 2** to **4** to put together your entire pool.

**SECTIONS 1, 2** and **3** have information for several different pool sizes and styles; follow the instructions carefully to make sure you use the information that apply to your specific pool.

**SECTION 1** also has **Safety Rules** and instructions to help you keep your pool clean and in good shape, year after year. Be sure to read the **Safety Rules**, and make sure everyone who uses your pool reads and understands them.

# B. Determine a Location for your Pool



## Important Note:

Ground preparation is one of the most important steps in the installation process. A **proper foundation** will ensure the rest of the pool assembly goes smoothly and that no problems will occur when the pool is filled with water.

Open all of the frame cartons and read all of the instructions **before you begin**. Be sure to read Section 2 and get a complete overview of the pool base and butress assembly before starting the ground preparation.

## 1. The Terrain

Pay special attention to choosing the right location for your pool:

- Choose a large area, as flat and level as possible.
- Choose a spot on dry, firm earth—**do not** install the pool on concrete, asphalt, tar paper, sand, gravel, peat moss, wood or chemically treated soil.
- Check with your pool dealer to see if Nut Grass grows in your area. This type of grass may grow up through your pool liner. Your dealer will be able to advise how best to treat the site.
- Sloped areas will need to be made level by digging away high spots, **not** by filling low spots—be prepared to hire earth-moving equipment if necessary.

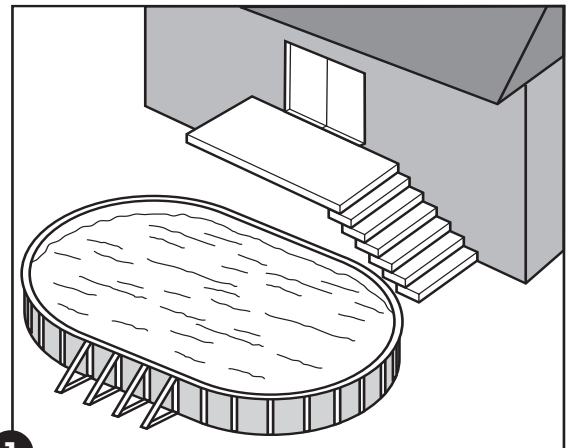

1

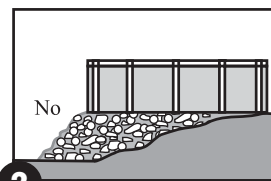

2

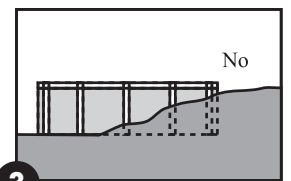

3

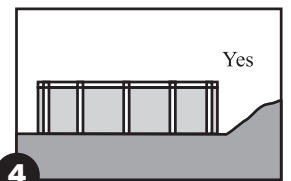

4



## 2. Things to Avoid

**Do not** locate your pool near or on any of the following:

- Overhanging tree branches.
- Overhead wires, clotheslines.
- Buried pipes and wires—contact your gas, electric and telephone utilities to find buried pipes and wires **before** you dig.
- Hilly and uneven terrain.
- Areas with poor drainage.
- Grass, stones and roots. Grass will rot underneath the pool liner, and stones and roots will damage the pool liner.
- Areas recently treated with oil-based weed killers, chemicals or fertilizers.

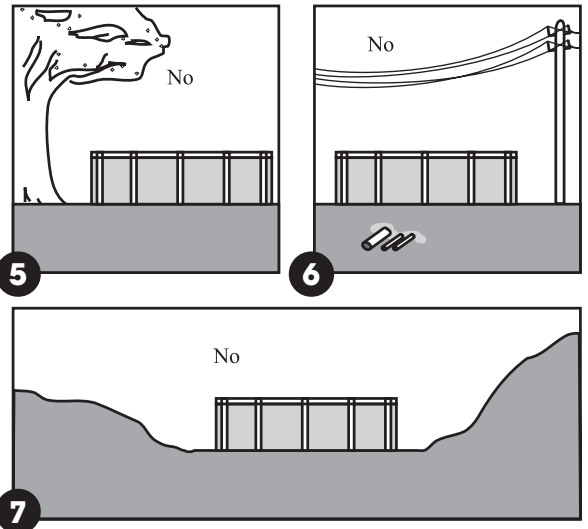

### Important:

When locating the centreline of the pool, **be sure** to take into consideration any structures (deck, patio, house) or relevant items (change rooms, gazebo, etc.) that the pool may need to line up with and ensure that the pool is in the most visual pleasing location for your property.

## 3. Plan Ahead

- Will you be adding an adjacent deck later? Be sure to leave room.
- Will you be using pool accessories or other appliances that need electricity or gas? Locate your pool near these services or plan to have them installed later by a licensed contractor.

# C. Prepare the Foundation of your Pool

## 1. Choose the Correct Ground Preparation Drawing

- Choose the drawing that matches your pool size from the five plan drawings below. This drawing will have all of the necessary dimensions for the ground preparation instructions that follow.

### 15 x 30 Oval Pool Dimensions

<b>R</b>	90" (229 cm)
<b>S</b>	102" (259 cm)
<b>L</b>	90" (229 cm)
<b>M</b>	30-1/2" (77 cm)
<b>N</b>	59-1/2" (151 cm)
<b>P</b>	180" (457 cm)
<b>W</b>	129" (328 cm)
<b>X</b>	90" (229 cm)
<b>Y</b>	127-1/4" (323 cm)
<b>Z</b>	157-1/4" (399 cm)

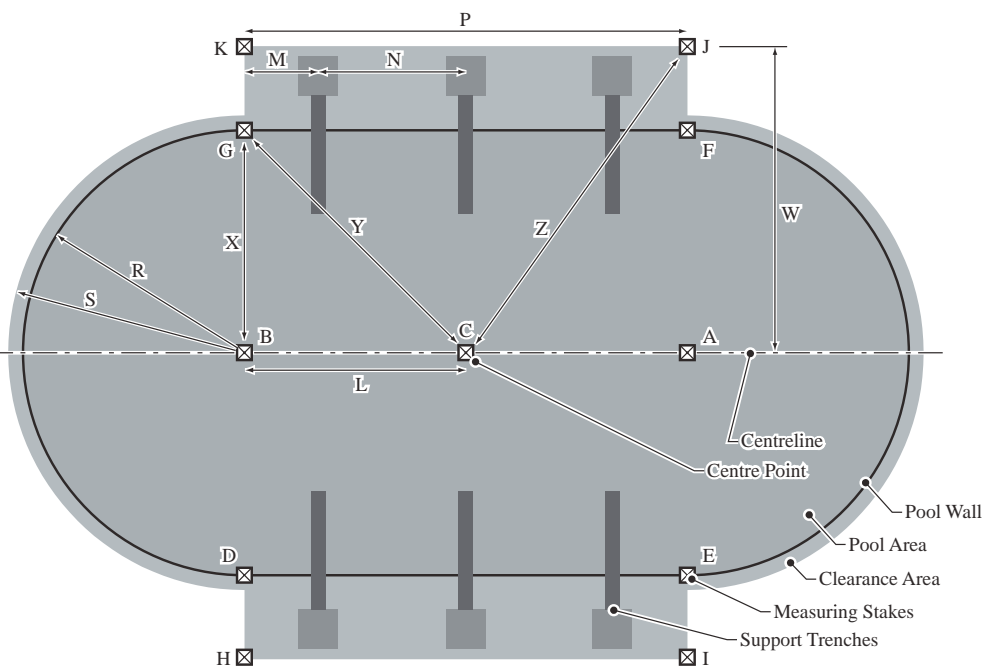

### 12 x 18 Oval Pool

#### Dimensions

<b>R</b>	72" (183 cm)
<b>S</b>	84" (213 cm)
<b>L</b>	36" (91 cm)
<b>M</b>	36" (91 cm)
<b>P</b>	72" (183 cm)
<b>W</b>	111" (282 cm)
<b>X</b>	72" (183 cm)
<b>Y</b>	80-1/2" (204 cm)
<b>Z</b>	116-3/4" (297 cm)

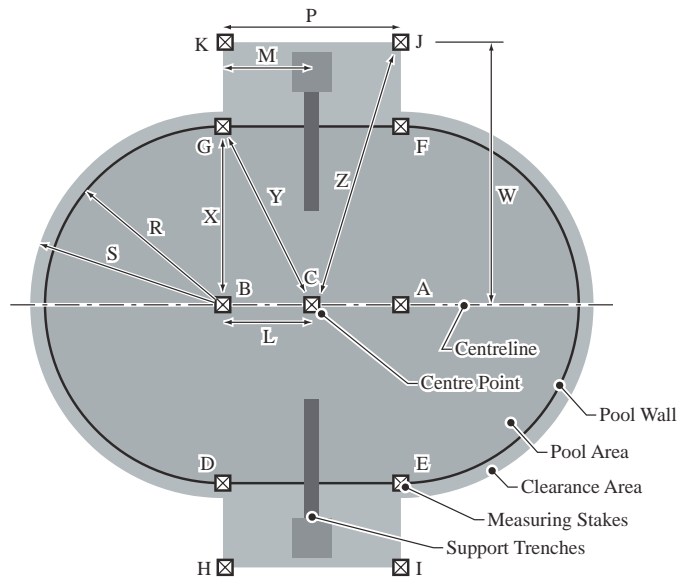

### 12 x 24 Oval Pool

#### Dimensions

<b>R</b>	72" (183 cm)
<b>S</b>	84" (213 cm)
<b>L</b>	72" (183 cm)
<b>M</b>	24" (61 cm)
<b>N</b>	48" (122 cm)
<b>P</b>	144" (366 cm)
<b>W</b>	111" (282 cm)
<b>X</b>	72" (183 cm)
<b>Y</b>	101-3/4" (258 cm)
<b>Z</b>	132-1/4" (336 cm)

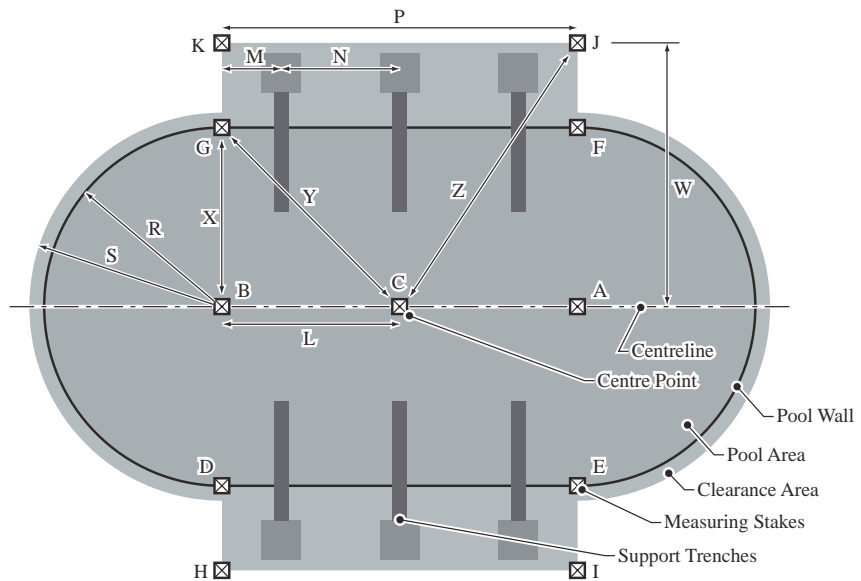

### 15 x 24 Oval Pool

#### Dimensions

<b>R</b>	90" (229 cm)
<b>S</b>	102" (259 cm)
<b>L</b>	54" (137 cm)
<b>M</b>	30" (76 cm)
<b>N</b>	48" (122 cm)
<b>P</b>	108" (274 cm)
<b>W</b>	129" (328 cm)
<b>X</b>	90" (229 cm)
<b>Y</b>	105" (267 cm)
<b>Z</b>	139-7/8" (355 cm)

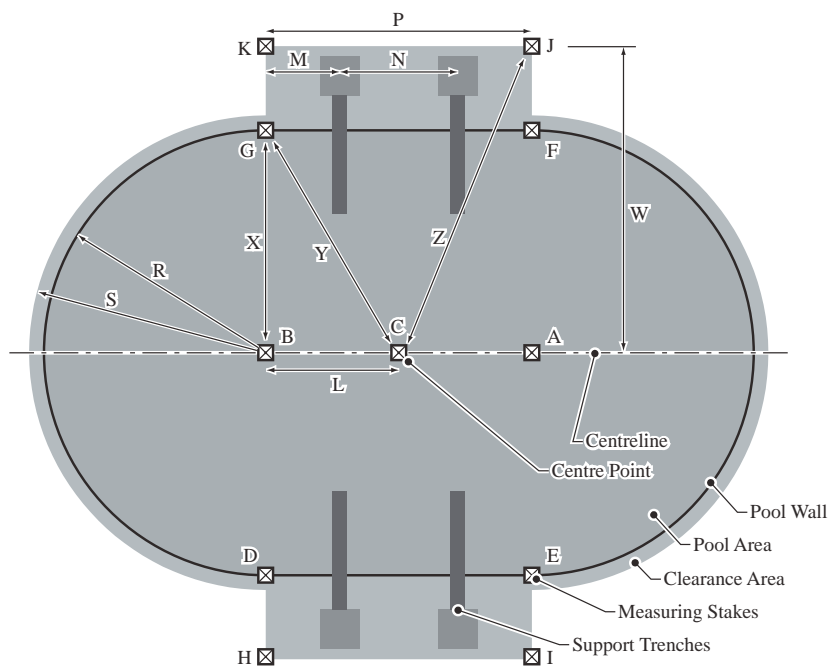

No Diving or Jumping.



Observe all Safety Rules.

## 18 x 33 Oval Pool Dimensions

<b>R</b>	108" (274 cm)
<b>S</b>	120" (305 cm)
<b>L</b>	90" (229 cm)
<b>M</b>	30-1/2" (77 cm)
<b>N</b>	59-1/2" (151 cm)
<b>P</b>	180" (457 cm)
<b>W</b>	147" (373 cm)
<b>X</b>	108" (274 cm)
<b>Y</b>	140-5/8" (357 cm)
<b>Z</b>	172-3/8" (438 cm)

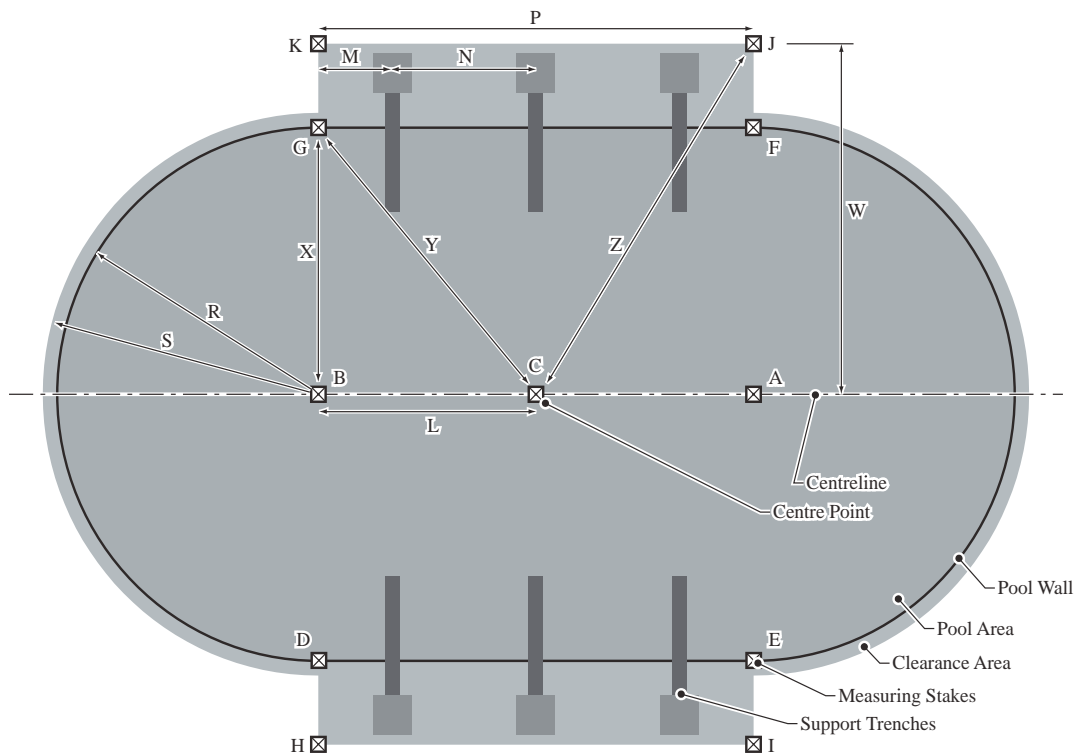

### Important:

Determine the location of your pool. **Make sure** you have the proper distances away from any adjacent structures (i.e. fences, house etc.). Contact local authorities for this information and any additional requirements governing the installation of a pool in your area.

By using the distances provided by local authorities and adding them to dimension **S** from the drawings above, you can calculate the location of the centreline of the pool.

## 2. Mark out the Area

- Drive two pegs (A) and (B) into the ground. These pegs will both be on the **centreline** of your pool. Choose the right distance between them from the chart below. **Note:** Distance **A** to **B** is equal to dimension **P** on the pool drawings above.

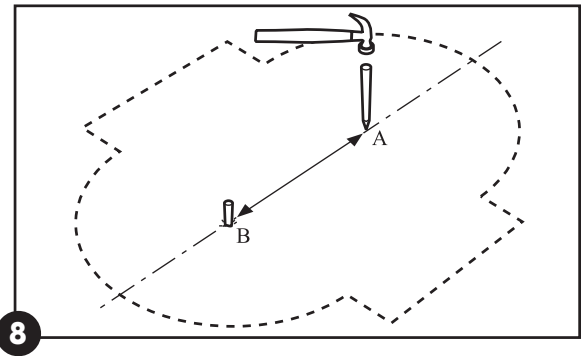

Pool Size	Distance between two pegs (A) and (B)
12' x 18'	72" (183 cm)
12' x 24'	144" (366 cm)
15' x 24'	108" (274 cm)
15' x 30'	180" (457 cm)
18' x 33'	180" (457 cm)

- Use a length of string tied between peg (A) and a can of spray paint, and mark a circle on the ground. Next, do the same for peg (B). Choose the length of string you need for your pool from the chart on the next page. The circles will be 12" (30 cm) bigger all round than the pool.

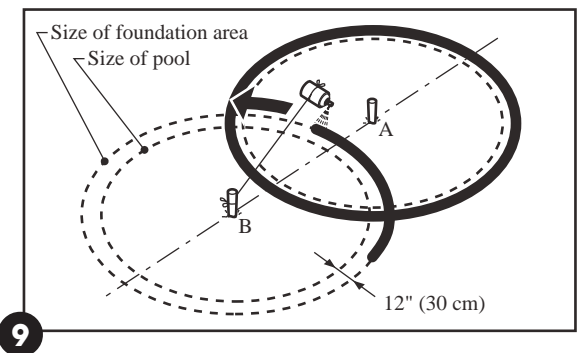

Pool Size	Length of String
12' x 18'	84" (213 cm)
12' x 24'	84" (213 cm)
15' x 24'	102" (259 cm)
15' x 30'	102" (259 cm)
18' x 33'	120" (305 cm)

- c. Join the two pegs (A) and (B) with a piece of string. Use this string as a guide to paint your centreline on the ground with the can of spray paint.

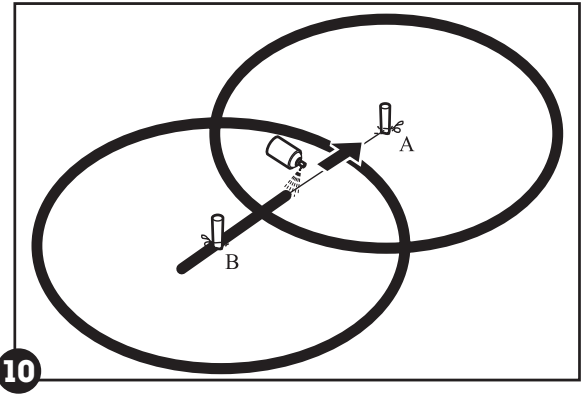

**Important:**

Measure carefully to make sure the centre stake (C) is in the correct location, **exactly halfway** between pegs (A) and (B). You will use stake (C) later as a reference point for other measurements.

- d. Drive a flat-topped stake (C) **exactly halfway** between the two pegs (A) and (B) on the centreline. Stake (C) will mark the exact centre point of your pool. The stake must be at least 1" (25 mm) square and 6" (15 cm) long. Drive it down flush with the ground surface.
- e. Replace the two pegs (A) and (B) with two more flat-topped stakes. Drive them down flush with the ground surface.
- f. Join the two circles with straight lines to make an oval. Use pegs and a piece of string as a guide for the can of spray paint.

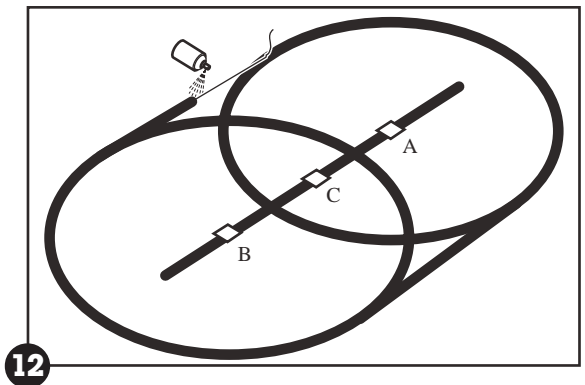
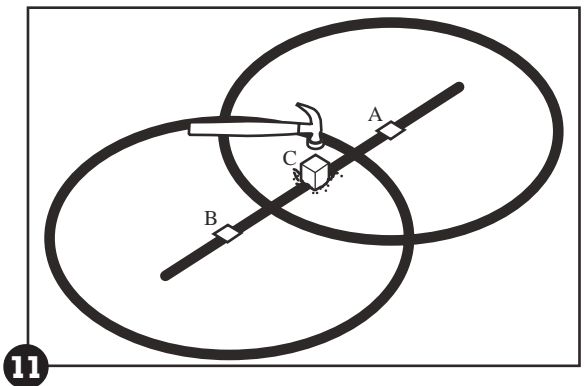

- g. Mark areas along both straight sides of your oval. Use pegs and string as a guide for the can of spray paint to mark straight lines. Use the chart below to find the correct **width W** from the centreline of the pool. The ends of the side areas should line up squarely with stakes (A) and (B).

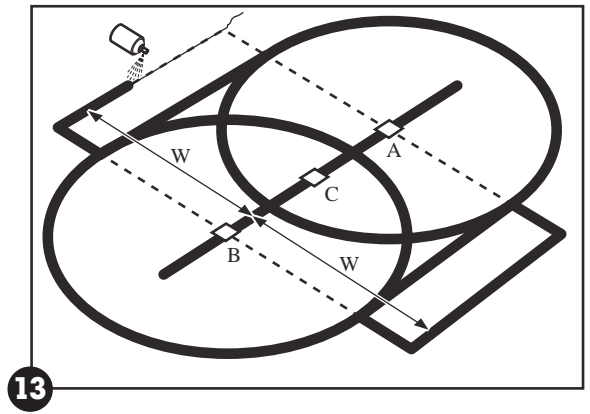

Pool Size	Distance from Centreline for Side Area W
12' x 18'	111" (282 cm)
12' x 24'	111" (282 cm)
15' x 24'	129" (328 cm)
15' x 30'	129" (328 cm)
18' x 33'	147" (373 cm)

### 3. Remove the Sod

- Remove all sod and plants from the area.
- Remove any sticks, stones and roots from the area.

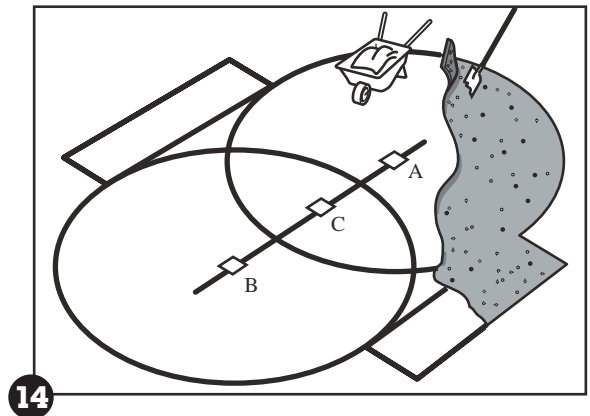

### 4. Make the Area Flat and Level

- You will use a 2-by-4 to help level the pool foundation area. Choose the length of **straight** 2-by-4 you need for your pool from the chart below.

Pool Size	Length of 2-by-4
12' x 18'	84" (213 cm)
12' x 24'	84" (213 cm)
15' x 24'	102" (259 cm)
15' x 30'	102" (259 cm)
18' x 33'	120" (305 cm)

- Adjust the height of the stake (A, B or C) that is located at the **lowest** end of the pool area by hammering it down until it is **exactly** level with the ground. Place a carpenter's level on a 2-by-4 and place the board across the three stakes to make sure the tops are exactly level with each other. Adjust the other two stakes down as needed.



#### Remember:

Your pool must be perfectly level. Take the time you need to be sure your foundation is perfectly level.



- c. Nail one end of the 2-by-4 to the top of the stake where the level of the pool foundation is **lowest**. Drill a hole for the nail in the **centre** of the top of the stake first and make the hole big enough so the nail is a little loose and can be removed without moving the stake. Mark the centre of the stake before you drill the hole by marking lines diagonally from opposite corners (see diagram 16). Use a nail long enough to hold the end of the 2-by-4 to the stake while you rotate it in a circle.

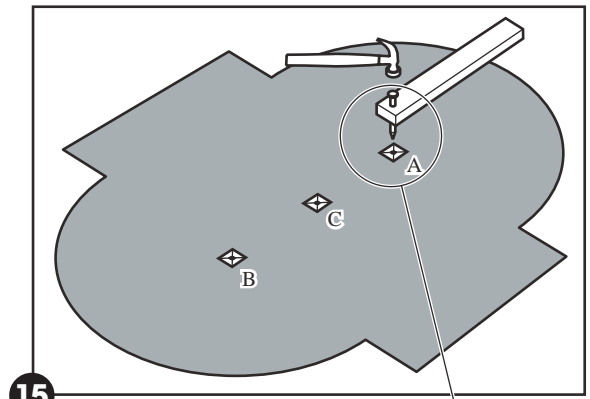

15

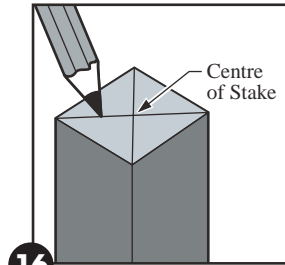

16

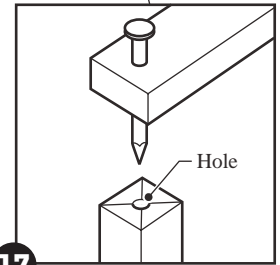

17

- d. Put a carpenter's level on the 2-by-4 and swing the board in a circle to find the high and low spots.

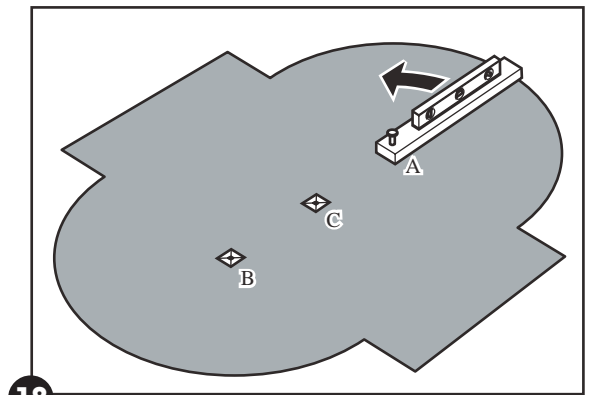

18

- e. Remove all the high spots with a shovel, hoe or rake. Be prepared to hire earth-moving equipment if you need to level a large area. Remember, your pool **must** be level within 1" (25 mm) across the pool. If necessary, adjust the height of the stake and keep scraping away soil until the area is level.

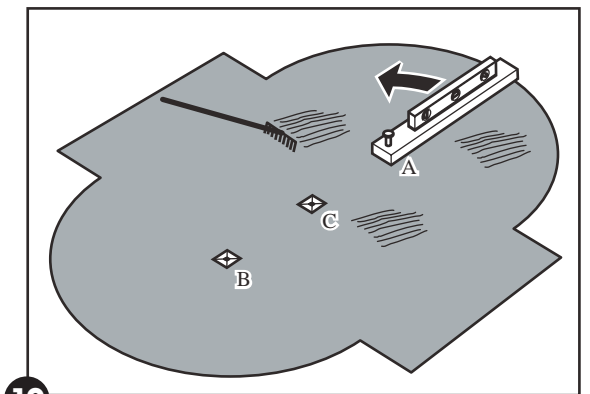

19

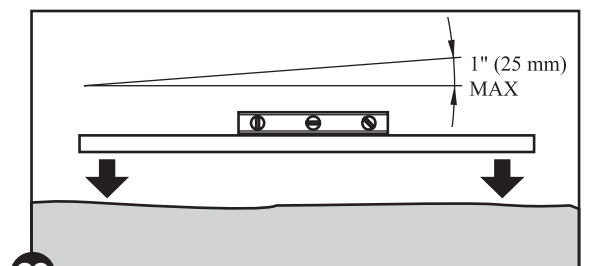

20



**Hint:**

Use a surveyor's transit instead of a carpenter's level, if one is available.





- f. **Do not** fill in low areas. Filling will create an unsafe foundation for your pool. Holes from small stones and small dips and hollows may be filled in, but the soil **must** be hard-packed with a tamping tool.

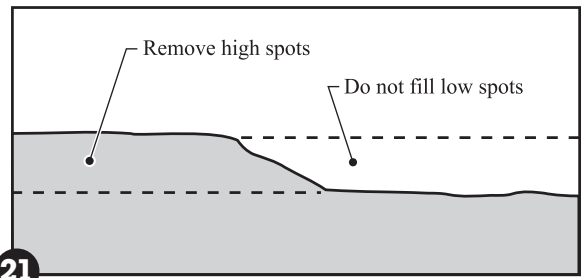

21

- g. Remove the 2-by-4 from the stake and nail it to the next stake on the centreline.
- h. Repeat the last five steps until the whole oval area is level. Take your time and make sure the area is **perfectly level**. Remember, your pool **must** be level within 1" (25 mm) across the pool. If necessary, adjust the height of each stake and keep scraping away soil until the entire area is level.

- i. Make the wide areas along the sides of the oval level with the rest of the area.
- j. Recheck the outer 12" (30 cm) of the round ends, where the pool wall will be, and the areas along the straight sides of the oval. Make sure there are no high or low spots. The bottom edge of the pool **must** rest flat on the ground and have no gaps under it.

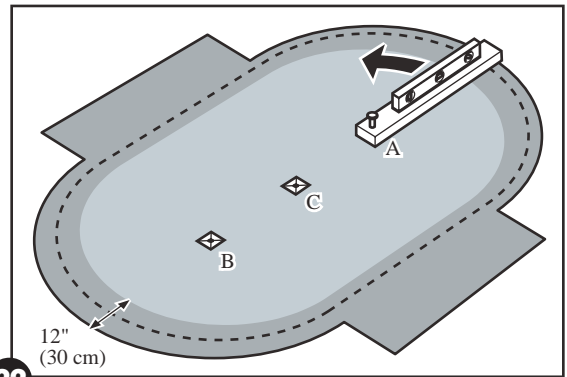

22

### 5. Add Corner Stakes

- a. Prepare eight corner stakes (D), (E), (F) & (G), and (H), (I), (J) & (K) by marking the centre point of each stake the same way as in step 4(c).

- b. Drive the eight corner stakes into the ground. Drive them down flush with the ground surface. Locate each stake exactly by using the measurements for your pool in the chart below. Be sure to measure using the centre point of each stake.

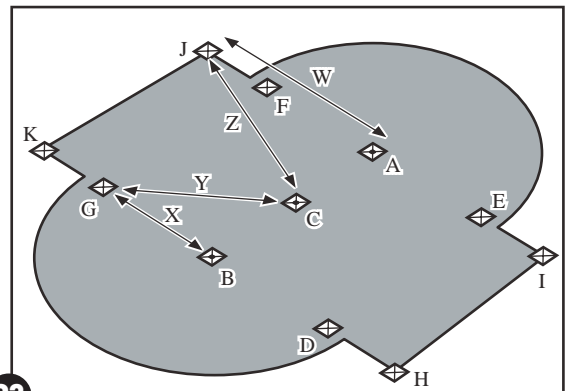

23

- c. Tie strings between stakes (H) and (I) and between (J) and (K).

Pool Size	Distance X	Distance Y	Distance W	Distance Z
12' x 18'	72" (183 cm)	80-1/2" (204 cm)	111" (282 cm)	116-3/4" (297 cm)
12' x 24'	72" (183 cm)	101-3/4" (258 cm)	111" (282 cm)	132-1/4" (336 cm)
15' x 24'	90" (229 cm)	105" (267 cm)	129" (328 cm)	139-7/8" (355 cm)
15' x 30'	90" (229 cm)	127-1/4" (323 cm)	129" (328 cm)	157-1/4" (399 cm)
18' x 33'	108" (274 cm)	140-5/8" (357 cm)	147" (373 cm)	172-3/8" (438 cm)



#### Remember:

The outer 12" (30 cm) of the cleared oval area must be perfectly flat. The bottom edge of the pool **must** rest flat on the ground and have no gaps under it. Take the time you need to be sure this area is perfectly flat and level.



#### Hint:

Instead of wooden corner stakes, you can use 12" (30 cm) spikes.



## 6. Prepare Buttress Trenches

- Locate the first trench by measuring the **distance M** from the centre of stake (H) to the **centreline** of the trench. Use the chart below to find the right distance M for your pool.
- Place a stake in the ground on the edge of the cleared area at distance M, underneath the string added in step 5(c).

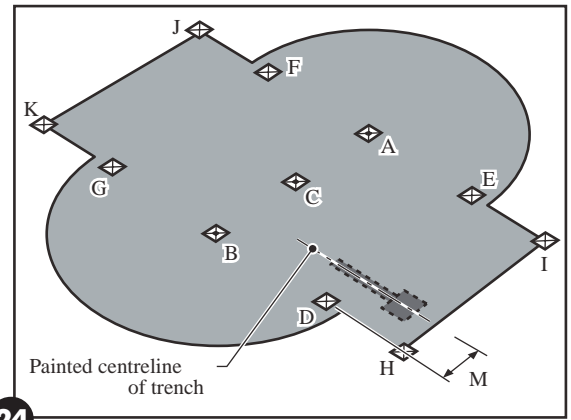

24

Pool Size	Distance from Stake to Trench Centreline M	Distance between Trenches N
12' x 18'	36" (91 cm)	n/a
12' x 24'	24" (61 cm)	48" (122 cm)
15' x 24'	30" (76 cm)	48" (122 cm)
15' x 30'	30-1/2" (77 cm)	59-1/2" (151 cm)
18' x 33'	30-1/2" (77 cm)	59-1/2" (151 cm)

(n/a = not applicable)

- Repeat steps (a) and (b) to locate the next trench along the side of the pool. Measure the **distance N** from the centreline of the first trench to the centreline of the next trench. Use the chart above to find the right distance N for your pool. (**Important Note:** The 12 x 18 pool has only **one** trench per side; the 15 x 24 pool has **two** trenches per side; the 12 x 24, 15 x 30 and 18 x 33 pools all have **three** trenches per side.)

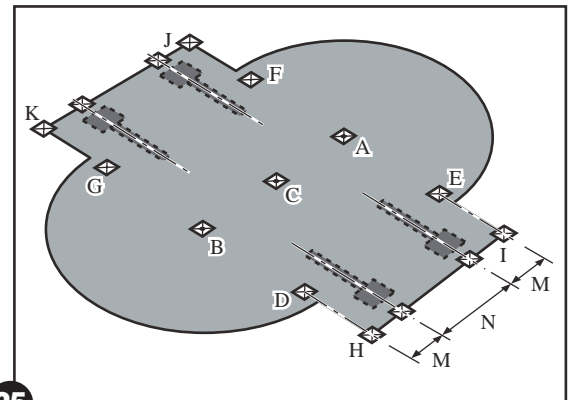

25

- Place another stake in the ground on the edge of the cleared area at distance N, underneath the string added in step 5(c).
- Repeat steps (a) to (d) for the other side of your pool.
- Tie a string between each pair of stakes on opposite sides of the cleared area (the stakes added in steps (b) and (d), above) to mark the centreline of the trenches.
- Mark the centrelines along each string with the can of spray paint.
- Recheck your measurements. Make sure the distances M and N **exactly** match the distances given in the chart above (see also diagram 26) and that the centrelines for the trenches are **exactly parallel**.
- Remove the strings. (**Note:** Keep the strings. They will be temporarily replaced later, after the trenches are dug out, to help you doublecheck that the trenches are parallel.)





**Hint:**

**Crushed limestone** or equivalent **must** be used instead of brick sand or vermiculite to backfill the base U-channels. The level of compaction achieved by using crushed limestone or equivalent is superior to that of brick sand or vermiculite.

- j. Carefully dig out each trench. Measure from the centreline painted on the ground and the line between the stakes. **Do not** dig the trenches too large or too

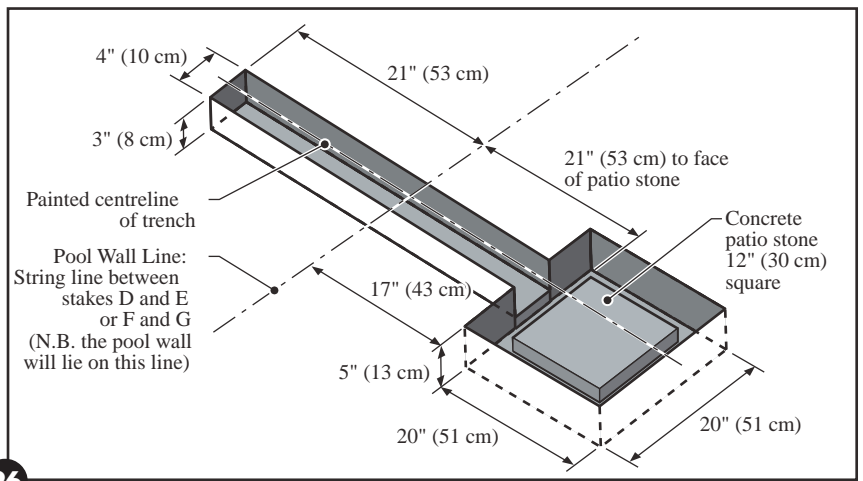

deep; the ground around the edges of each trench **must** remain firm and undisturbed.

- k. Temporarily replace the strings removed in step (i) to check that the trenches are **exactly parallel**. Remove the strings again when you are finished.

- l. Spread a layer of crushed limestone (or equivalent) 1" (25 mm) thick into the bottom of the square part **only** of each trench (the part that contains the patio stone). Pack firmly.

- m. Place a concrete patio stone 12" x 12" square x 2" thick (30 x 30 x 5 cm) into the wide part of each trench, on top of the limestone layer. **Make sure** it is level and positioned correctly.

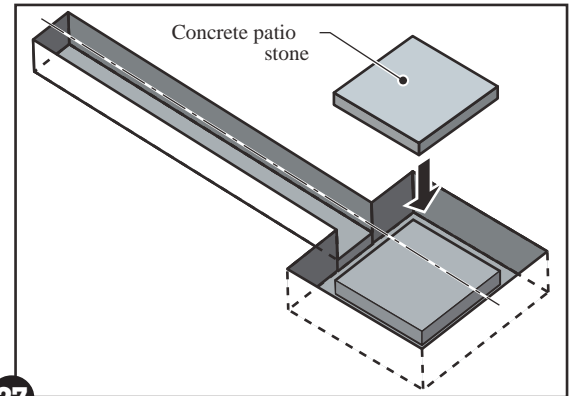

27

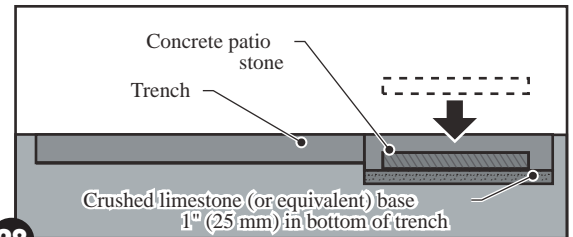

28

- n. Add another layer of crushed limestone (or equivalent) 1" (25 mm) thick into the bottom of the long, rectangular part of each trench, and around the patio stones and pack firmly. The top surface of the crushed limestone should be level with the top of each patio stone.

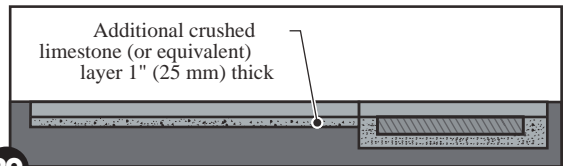

29

**• See the drawing on the next page for an overview of all the parts used to install the buttresses, verticals and base rails.**



**Caution:**

Brick sand or vermiculite **cannot** be used on any part of the buttress installation process. These materials have poor compaction properties that can cause problems with the buttresses after the pool has been filled with water.



**Caution:**

Make sure there is **adequate drainage** in the bottom of each trench and along the sides of the pool area. There **must** be adequate drainage for a safe and secure pool foundation.



# Parts List and Overview of Buttruss Assembly

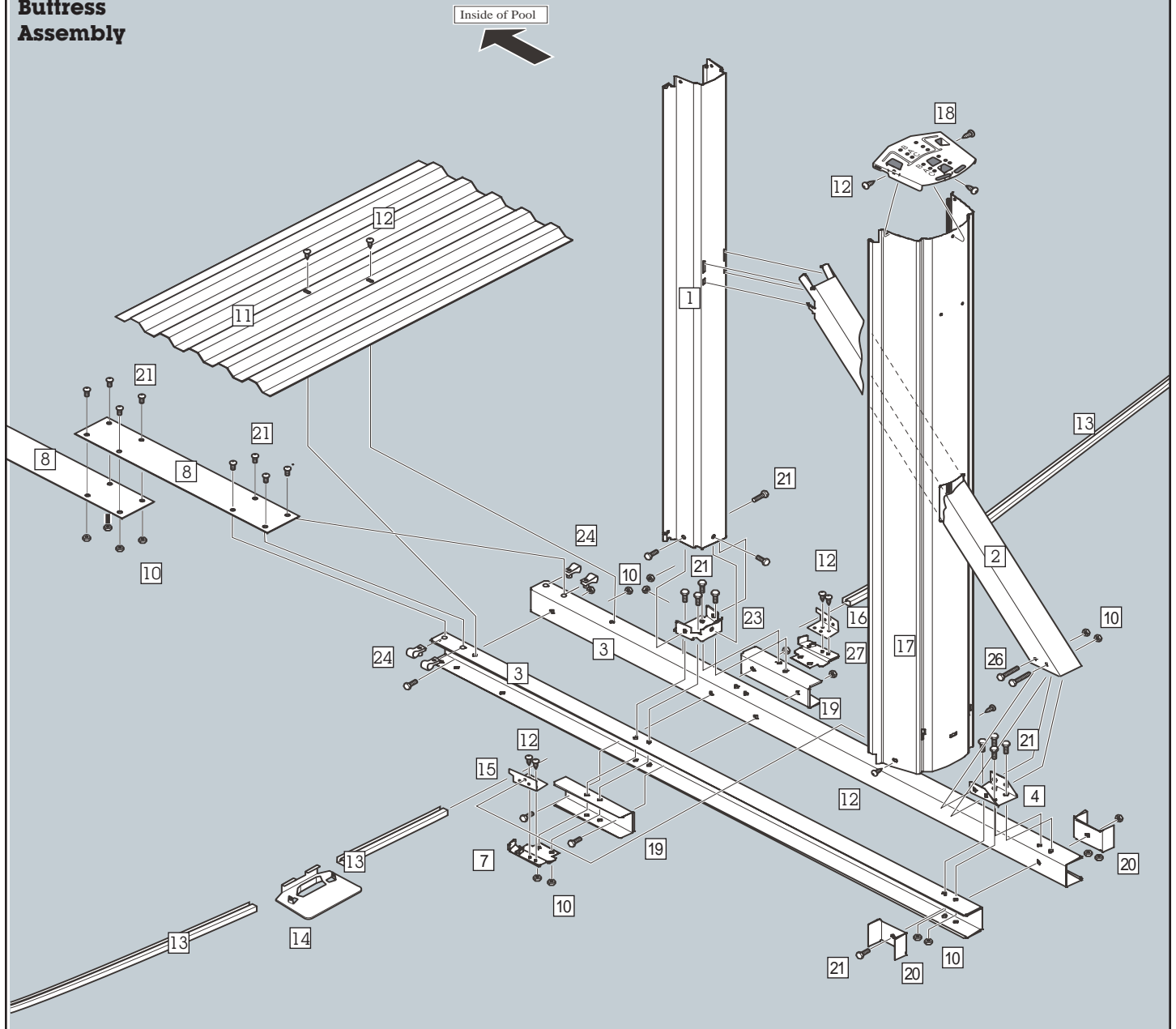





Key Part Name	Part No.	Qty.
1 Upright	(pool specific)	
2 Diagonal	(pool specific)	
3 Base Channel	1440336	2
4 Diagonal Bracket	1320152	1
7 Left Vertical Support Bracket	1320153	1
8 Strap	(pool specific)	
11 Hold Down Plate	1320165	1
13 Curved Bottom Rail	(pool specific)	
14 Base Plate	(pool specific)	
15 Left Vertical Clip	1320155	1
16 Right Vertical Clip	1320155	1
17 Vertical	(pool specific)	
18 Top Plate	(pool specific)	
19 Reinforcing Bracket	1320150	2
20 Support Bracket	1320151	2
23 Base Plate	1320154	1
27 Right Vertical Support Bracket	1320153	1

Key Part Name	Part No.	Qty.
- Hardware Bag (Green)	1184294	1
<i>1 per set of buttrusses; each bag contains:</i>		
10 1/4"-20NC serrated flange hex nut	1184052	46
12 No. 12 x 1/2" self-tapping screw, pan head Phillips	1183273	14
21 1/4"-20NC x 3/4" hex bolt	1184275	50
24 1/4"-20NC nut clip	1184278	8
26 1/4"-20NC x 2-1/4" hex head bolt	1184276	4

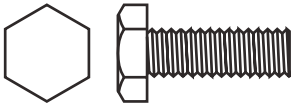
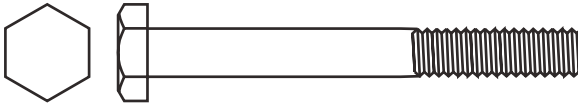

# HARDWARE FOR POOLS

DESCRIPTION	PART NUMBER	ACTUAL SIZE	TOOL REQUIRED FOR INSTALLATION
SELF TAPPING SCREW #12 x 1/2 INCH LONG	1183273		PHILLIPS NUMBER 3 SCREWDRIVER OR RED HANDLE #2 ROBERTSON SCREWDRIVER
SERRATED FLANGE HEXAGON NUT 1/4-20	1184052		7/16 INCH WRENCH OR SOCKET
HEXAGON HEAD BOLT 1/4-20 x 3/4 INCH LONG	1184275		7/16 INCH WRENCH OR SOCKET
HEXAGON HEAD BOLT 1/4-20x2-1/4 INCH LONG	1184276		7/16 INCH WRENCH OR SOCKET
NUT CLIP 1/4-20	1184278		NO TOOL REQUIRED





**Hint:**

Each reinforcing bracket (key 19) can be easily inserted into the base channel (key 3) by sliding it in from one end. Make sure the arrow is pointing the right way.

## 7. Begin Assembling the Buttresses Base Channels

- a. Assemble two base channels (key 3), two support brackets (key 20) and two reinforcing brackets (key 19) using four bolts (key 21) and nuts (key 10). The reinforcing brackets (key 19) are each marked with an arrow which should point **away** from the support brackets when the parts are assembled (these arrows will point **toward** the **inside** of the pool when the buttress assemblies are set into position around your pool). **Note:** the rest of the buttresses will be assembled later in Step 9, below.

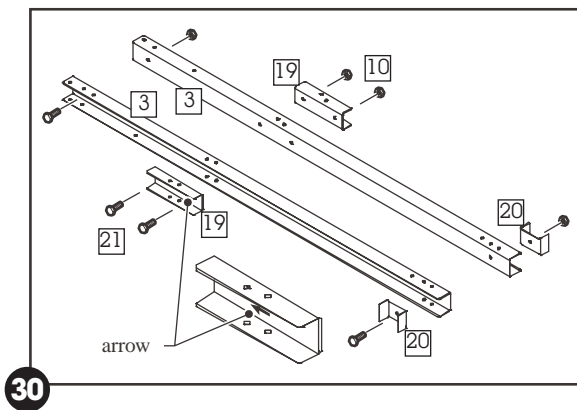

30

## 8. Install and Level the Base Channels

- a. Place one assembled base channel (key 50) into one of the trenches and move it so that the end of the base channel is 17" (43 cm) away from the string marking the Pool Wall Line (see diagram 32). Double check the position of the base channel by making sure the other end is 2" (5 cm) from the back edge of the concrete patio stone.

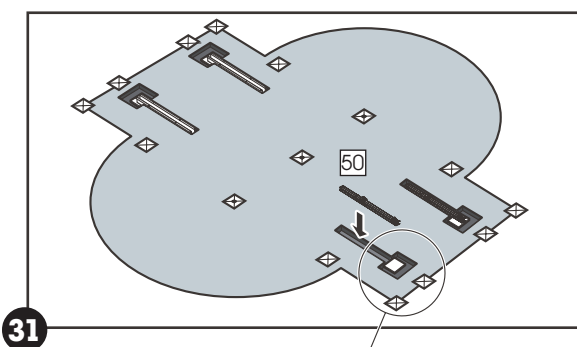

31

- b. Repeat steps 7(a) and 8(a) for the rest of the base channels and trenches.
- c. Use the carpenter's level to make sure the top of the base channel assembly is **exactly** level with the rest of the cleared area. If it is not, the base channel **must** be removed and the crushed limestone (or equivalent) and patio stone adjusted. Also make sure that the end of the base channel assembly is 17" (43 cm) away from the string marking the Pool Wall Line (see diagrams 32 and 33).

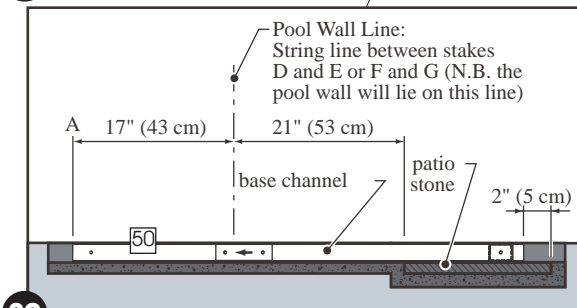

32

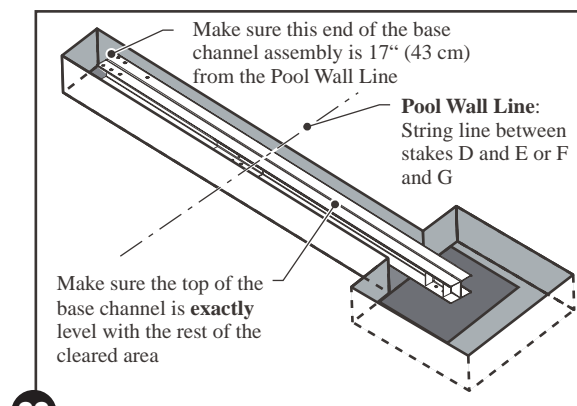

33



## 9. Continue Assembling the Buttresses

- a. Temporarily remove one base channel from its trench and fasten one diagonal bracket (key 4) to the base channel assembly (key 50) using four bolts (key 21) and nuts (key 10).

**Make sure** the angled part of the bracket is facing in the correct direction, as shown in diagram 34. The surface that the diagonal bracket is fastened to will be the **top** of the base channel assembly.

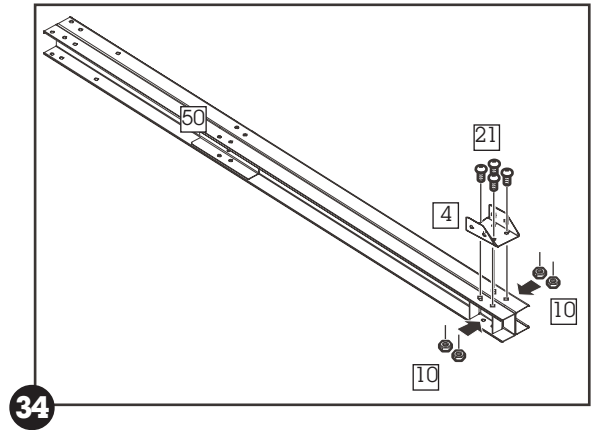

- b. The vertical support brackets (key 7 and 27) are supplied joined together in left-hand and right-hand pairs. Bend the clips along the centre seam to snap them apart.

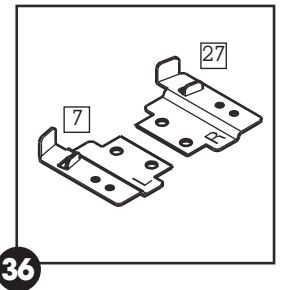
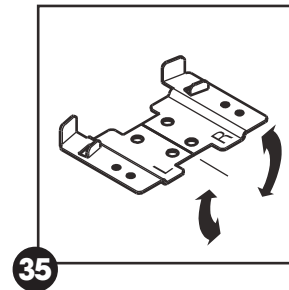

- c. Fasten one base plate (key 23) and two vertical support brackets (key 7 and 27) to the top of the base channel assembly (key 50) using four bolts (key 21) and nuts (key 10).

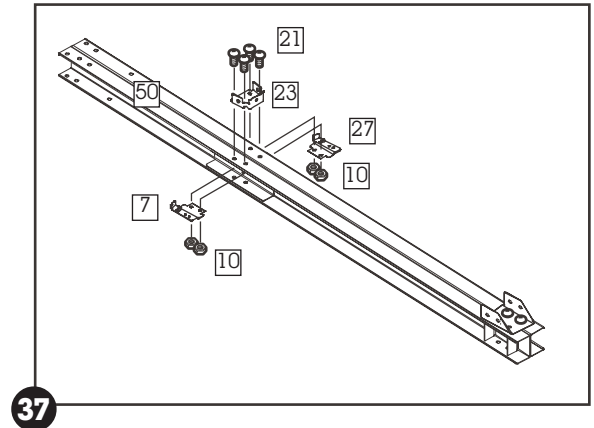

- d. Fasten on upright (key 1) to the base plate (key 23) using three bolts (key 21) and nuts (key 10). **Make sure** the bottom end of the upright is fastened to the base plate (the bottom end of the upright has three holes which are use to fasten to the base plate).

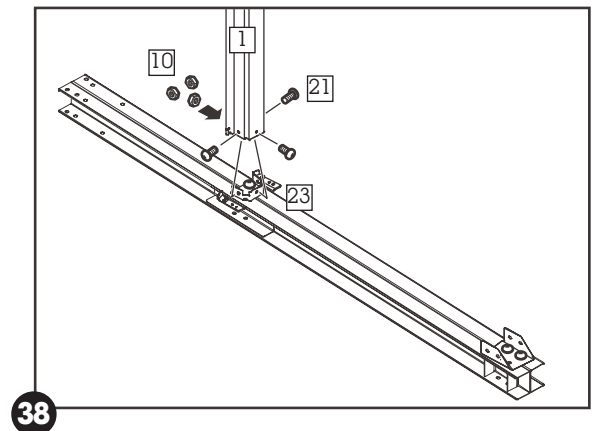

### Caution:

Failure to properly install and tighten all of the bolts and nuts may void the warranty on your pool.



- e. When you come to Section 2, you will install the base rails, linking them to the buttresses. **Make sure** now that there is approximately 1/16" (2 mm) gap under the tab at the bottom of each upright so the bottom rails slide on easily.

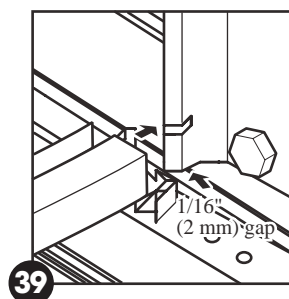

- f. Set the assembled buttress back into its trench. **Make sure** the buttress assembly is returned to the correct position in the trench with the end of the base channel aligned exactly 2" (50 mm) from the back edge of the concrete patio stone (see step 8(a)). The buttress may need to be propped upright to prevent it from falling over while the rest of the pool is assembled.
- g. Repeat steps (a) to (f) for the rest of the vertical and base channels.

## 10. Fill the Base Channels

- a. Tie strings between stakes (D) and (E) and between (F) and (G). These will be used as a reference to make sure the base channels are exactly lined up with each other. Stand at each corner of the pool and check the alignment of the base channels with the strings.

- b. Jump to Section 2 and complete steps 1(a) and (b). This will allow you to install the bottom buttress rails, ensuring the correct distance between the buttresses before the trenches are filled in. **Important:** complete only steps 1(a) and (b) for now, and then continue with step 10(c) below; you will complete the rest of Section 2 later.

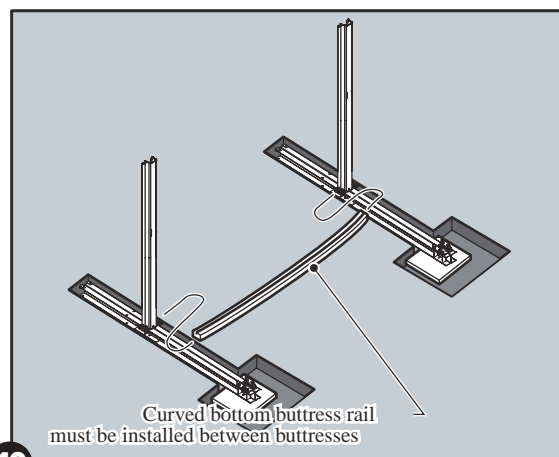

- c. Fill the base channels and the trenches they sit in with crushed limestone (or equivalent). Fill them up to the top edges of the base channels. If the limestone is dry spray it with some water to help with the compaction. Stand on the base channel and tamp down the limestone until a solid base is achieved (by standing on the base channel your weight helps prevent the base channel from moving). Add additional limestone as required. Do not tamp too hard or the base channel will move.

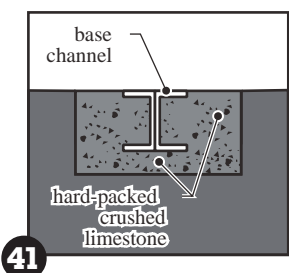

- d. Recheck the distances between the base channels and make any adjustments you need to make sure the spacing is exactly right (refer to page 1-10, Step 6 for measurements).







**Hint:**

Use one end of a 2-by-4 as a tamping tool. Spray the crushed limestone with water before packing it down hard.



**Hint:**

**Crushed limestone** or equivalent **must** be used instead on brick sand or vermiculite to backfill the base channels. The level of compaction achieved by using crushed limestone or equivalent is superior to that of brick sand or vermiculite.



**Caution:**

Brick sand or vermiculite **cannot** be used of any part of the buttress installation process. These materials have poor compaction properties that can cause problems with the buttresses after the pool has been filled with water.

**11. Install Hold Down Plates and Straps**

a. **Gently** flatten any kinks or bends out of the straps (key 8).

b. Using a straight edge (you can use one of the hold down plates), drag along the top edge of the base channel to ensure the ground is **exactly** even and level with the base channel (the area 20" (51 cm) beyond each side of the base channel must be level too). If it is not level, spread some crushed limestone (or equivalent) on the ground. Stand on the base channel and tamp it down hard with a tamping tool. Verify the ground is level to the base channel by running the straight edge along the top edge of the base channel again. Repeat this step until the ground is level.

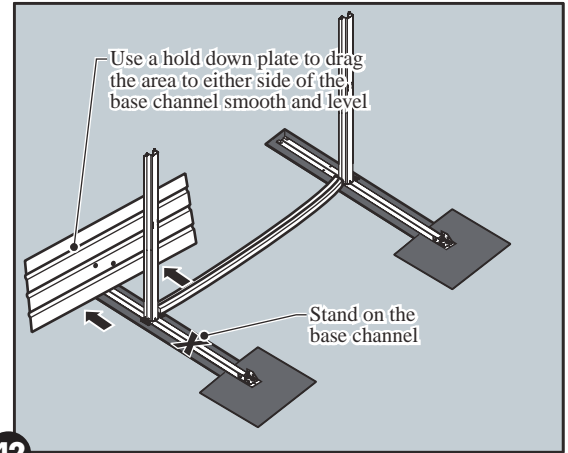

42

c. Slide four nut-clips (key 24) onto one end of the base channel assembly (the end that the arrow points to) so they line up over the holes in the base channel. The threaded parts of the nut-clips must point **down**.

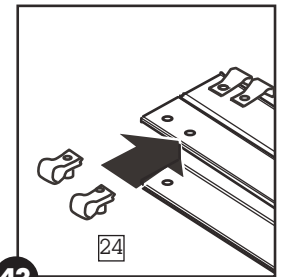

43

d. Line up the holes in the strap (be sure to use the holes shown in diagram 44) with the nut clips (key 24) at the end of the base channel (key 50) and fasten together with four hex head bolts (key 9). Tighten the bolts snugly but do not overtighten.

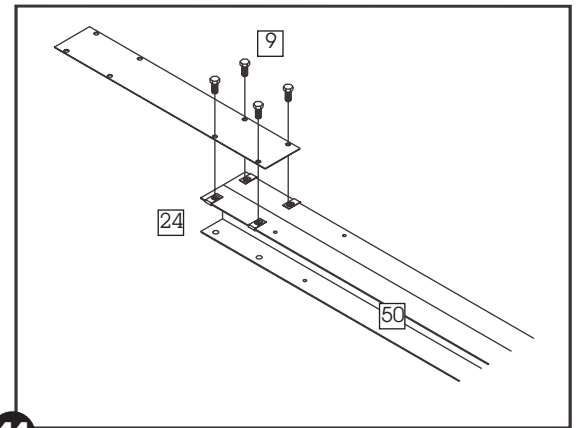

44

e. Repeat steps (b to d) for the corresponding strap on the opposite side of the pool.



- f. Spread 3/4" (19 mm) of crushed limestone (or equivalent) over the area for the hold down plate.

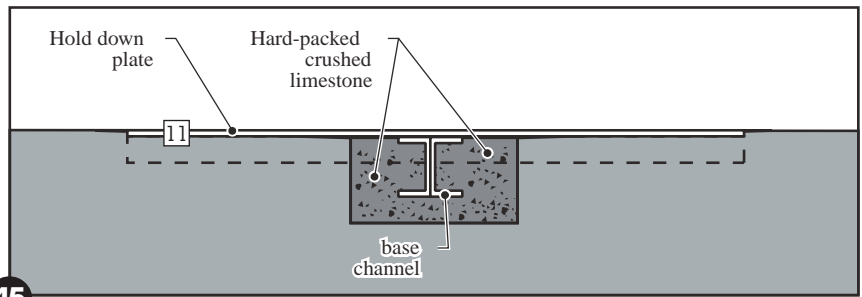

Do not spread any material over the top of the base channel. Place the hold down plate as shown in diagram 46 on top of the crushed limestone. Begin shifting the hold down plate in a forwards and backwards motion (see diagram 47), while simultaneously applying a downward force on the hold down plate until the plate rests on top of the base channel. Check to see that the outside ends of the hold down plate have filled with material, and insert material into any open areas until they are full. This will prevent any low spots from forming around the hold down plates when the pool is filled with water.

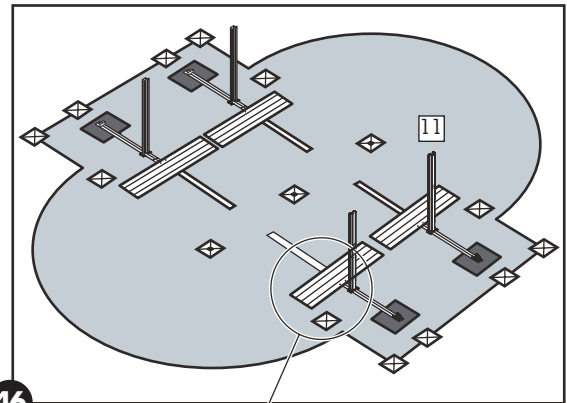

46

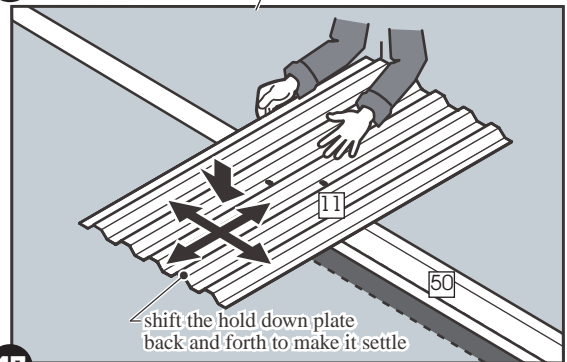

47

**Important:** **make sure** each entire hold down plate lies completely flat. The hold down plate **must** lie flat or it may lift and damage the pool liner after the pool is filled with water.

- g. Line up the holes in the hold down plate (be sure to use the holes shown in diagram 48) with the holes in the base channel (key 50) and fasten with two self-tapping screws (key 12).

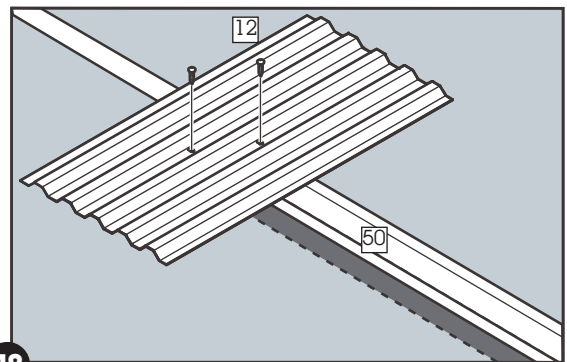

48



**Hint:**

When lining up the holes in the base channel and the hold down plate, ensure the bolt heads in the strap are in the first two grooves of the hold down plate.

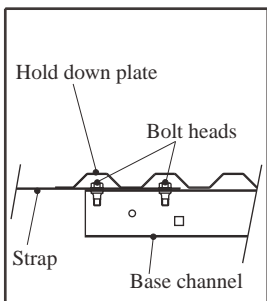

h. Repeat steps (f) and (g) on the opposite side of the pool.

g. **Make sure** the area across the middle of the pool between the buttresses is **flat and level**. Join the two straps already installed with any additional straps (key 8) together to make a full-length strap, joining the two sides of the pool (**Note:** the 12 x 18 and 12 x 24 pools do not have any additional straps). Line up the holes and fasten together with four bolts (key 21) and four nuts (key 10). The bolt heads must be on the **top** and the nuts **underneath**. Tighten the bolts.

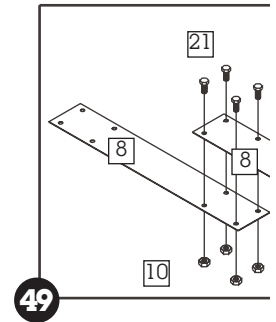

h. Repeat steps (b) through (g) for the rest of the buttresses and hold down plates. Tighten all of the bolts.

## 12. Remove the strings and stakes

a. Make sure all of the strings and stakes (**except** stakes (A) and (B)) are removed from the entire pool area and fill in any holes with crushed limestone (or equivalent). Leave stakes (A) and (B) in place for now; they will be used later to centre the pool wall.



# Assembling the Pool Base & Side Buttresses

## 1. Install the Curved Bottom Rails

- a. Each pool uses two, three or four different types of curved bottom rails (key 13). The rails are colour coded or stamped with a part number. Use the chart below to choose the types and quantities of bottom rails for your pool (part numbers are shown in brackets under each colour).

Pool Size	Quantity and Colour Code (with part numbers.)			
	Buttress Rail	Transition Rail A	Transition Rail B	End Rail
12' x 18'	n/a	4 yellow (no. 1460031) (no. 1460091)	n/a	8 plain (no. 1460029) (no. 1460089)
12' x 24'	4 white (no. 1460105) (no. 1460106)	4 blue (no. 1460108) (no. 1460107)	n/a	8 plain (no. 1460029) (no. 1460089)
15' x 24'	2 white (no. 1460105) (no. 1460106)	4 green (no. 1460033) (no. 1460093)	n/a	8 plain (no. 1460030) (no. 1460090)
15' x 30'	4 green (no. 1460033) (no. 1460093)	4 green (no. 1460033) (no. 1460093)	n/a	8 plain (no. 1460030) (no. 1460090)
18' x 33'	4 green (no. 1460033) (no. 1460093)	4 green (no. 1460033) (no. 1460093)	4 green (no. 1460033) (no. 1460093)	6 plain (no. 1460031) (no. 1460091)

(n/a = not applicable; plain = no colour code)

The 18 x 33 pool is the only size that uses all four types of rails. Diagram 1 shows the locations for each type.

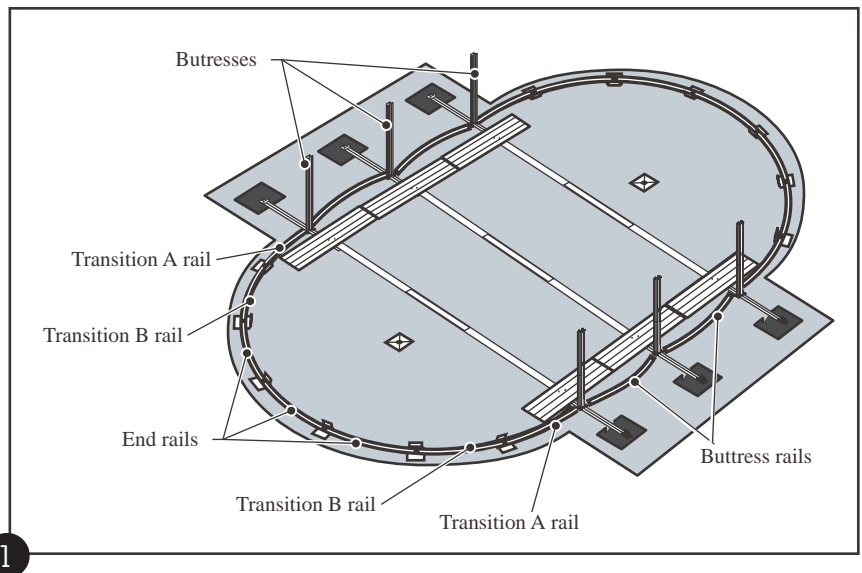



**Hint:**  
When measuring the distance to the face of each base plate, use a piece of string longer than required and place a mark on the string at the required distance.



**Hint:**  
Bend the first 1/8" (3 mm) of the end of the bottom rail slightly with a pair of pliers to make sure the rail doesn't slide out of the base plate when the pool wall is installed.

Cut several small pieces of wood approximately 3/8" x 3/8" (10 x 10 cm) square and place one between the two bottom rails located at each base plate. This will keep the bottom rails from closing while the wall is installed. Be sure to remove the blocks of wood later, before installing the verticals in Section 4.

- b. Insert the buttress rails between the buttresses (if you have a 12 x 18 pool, skip step (b) and go to step (c)). The bottom rails insert into the notch in the upright. Make sure the groove faces up.
- c. Insert the transition A rails (key 13). Slide one end of each rail into the notch in the upright (see diagrams 3 and 4) and slide the other end together with a base plate (key 14) (see diagrams 8, 9 and 10). **Important:** make sure you slide the rail into the notch so the closed, square part of the rail is in the notch, not the open groove part of the rail (see diagrams 5 and 6).
- d. Slide the other end of the transition A rail together with a base plate (key 14).
- e. If you have an 18 x 33 pool, insert the transition B rails (if you have any other size pool, skip to step (f)). Leave a 1/2" (13 mm) gap between the ends of the rails (see diagram 1 on the previous page for the 18 x 33 pool).
- f. Lay out the end rails and base plates on both round ends of the pool area. Using a piece of string attached to the centre of stake (A), measure the distance to the face of each base plate and make sure it is the same as dimension R (see pages 1-3 through 1-5). (Note: this step will not work on the buttress rails or transition rails.)
- g. Insert the end rails. Leave a 1/2" (13 mm) gap between the ends of the rails.

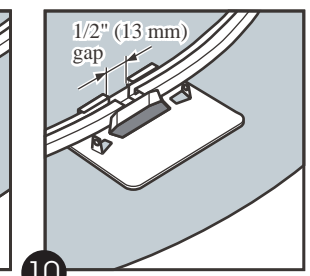
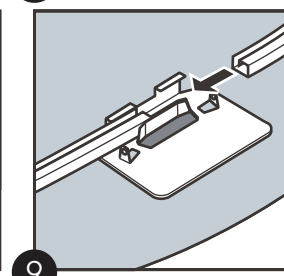
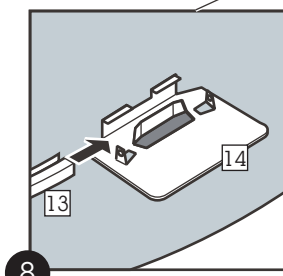
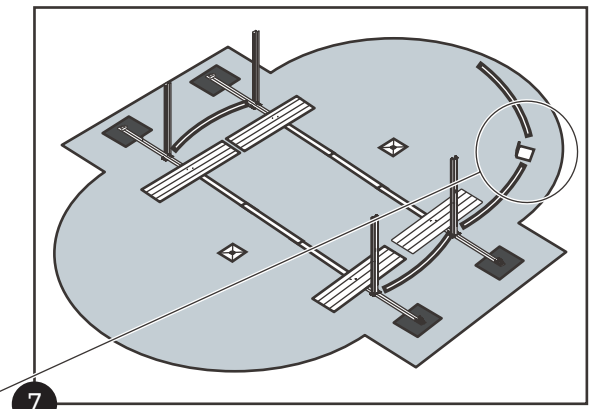
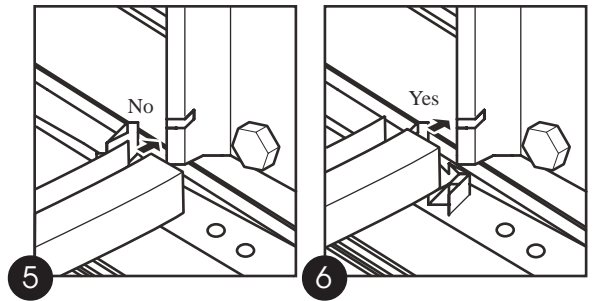
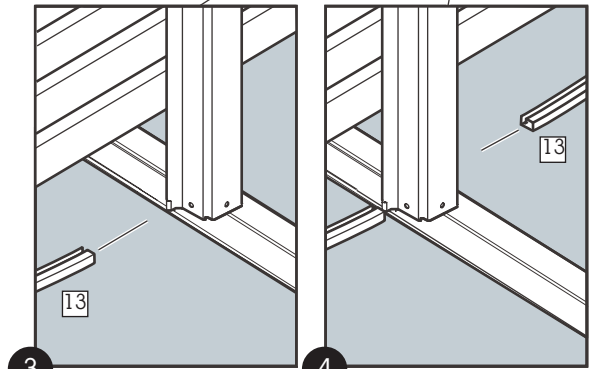
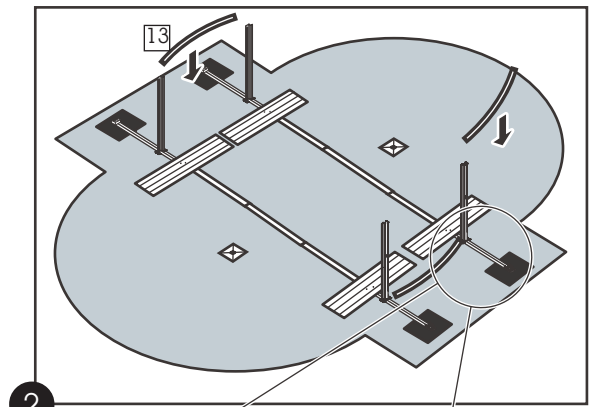



Note:

If you want, the patio stones around the round ends of the pool may be round instead of square, or they can be left out completely. The patio stones in the trenches under the buttresses along the straight sides must be used, even if you don't have them on the round ends.

If you want, instead of using patio stones you can make crushed limestone pads. Dig a 12" x 12" (30 x 30 cm) square hole 2" (5 cm) deep and fill the hole with crushed limestone, packing it down hard. Spray the crushed limestone with water as you pack it down.

h. Optional concrete patio stones may also be used under each base plate on the round ends of your pool. Patio stones 12" (30 cm) square or larger will do. They must be sunk into the ground so the tops are flush with the soil around them. Use the carpenter's level to make sure the patio stones are perfectly level and flush with the ground. Use the carpenter's level and a 2-by-4 between patio stones to make sure the stones are level with each other.

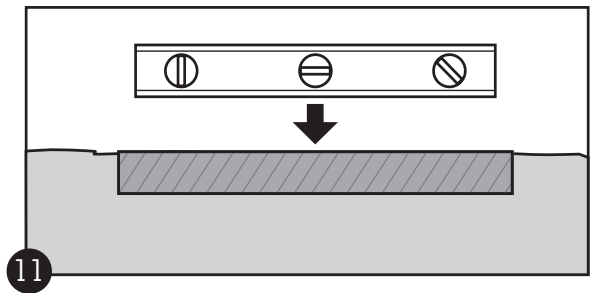

- i. Use a carpenter's level as you install each curved bottom rail to make sure it is level.
- j. Remove all the wooden stakes from the ground.

2. Install Vertical Clips

a. The vertical clips (key 15 and 16) are supplied joined together in left-hand and right-hand pairs. Bend the clips along the centre seam to snap them apart.

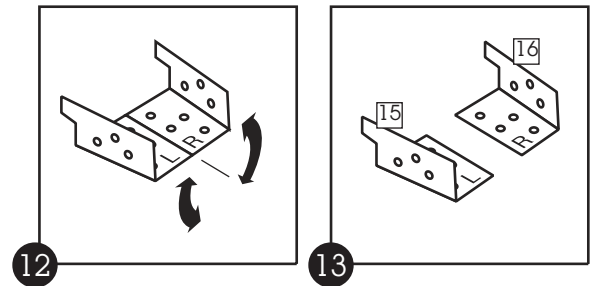

b. Fasten the left-hand vertical clip (key 15) with two self-tapping screws (key 12) to the vertical support brackets (key 7 and 27). (Note: the left-hand vertical clip is on the left when you are facing toward the centre of the pool.)

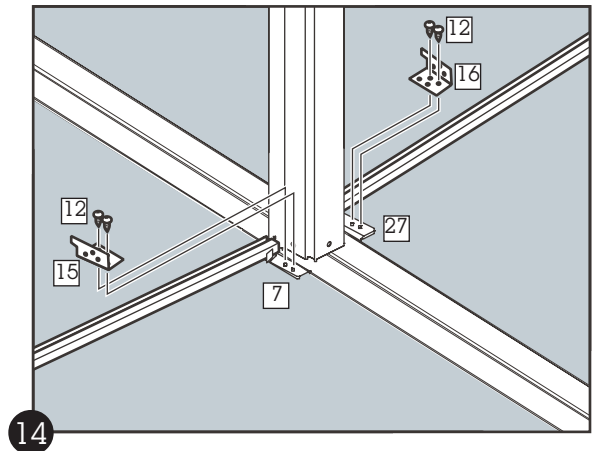

Important: be sure to use the pair of holes in the vertical clip as shown in diagram 15, and use the profiles of the vertical in diagram 16 to identify which pool you have. If your vertical profile matches either profile X or Y, use the pair of holes marked B; all other pools use the pair of holes marked A.

- c. Tighten the screws.
- d. Repeat steps (b) and (c) for the right-hand vertical clip (key 16).
- e. Repeat steps (a) to (d) for the rest of the buttresses.

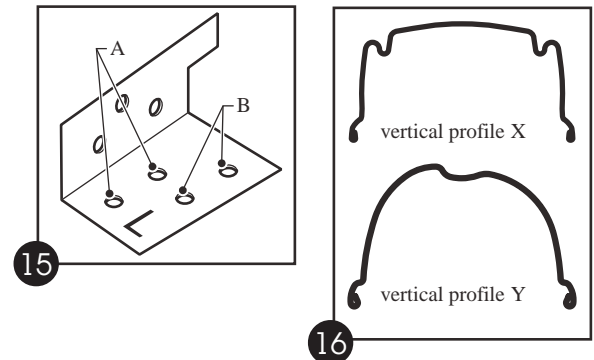

Hint:

Put duct tape along the top edge of the buttress so there are no exposed edges that might tear the pool liner or scratch the pool wall.





**Hint:**

Protect the top and side edges of the rectangular hole in the vertical with some duct tape to prevent the diagonal from being scratched during assembly. Remove the duct tape after the vertical has been attached to the diagonal brackets.

**3. Install the Verticals**

- a. Set one vertical (key 17) in place over an upright (key 1). Do not fasten it yet (you will fasten it in step 4(d) on the next page).
- b. Repeat step (a) for each of the buttresses. (Note: the rest of the verticals around the round ends of your pool will be installed later.)

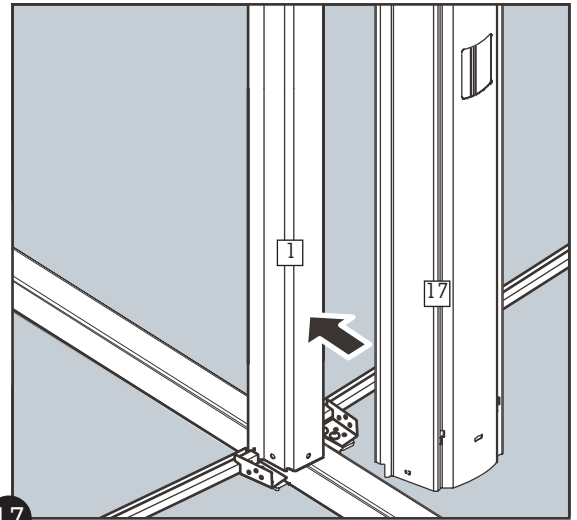

17

**4. Install the Diagonals**

- a. Hold one diagonal brace (key 2) approximately horizontal, insert the four tabs at

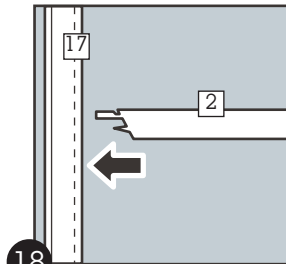

18

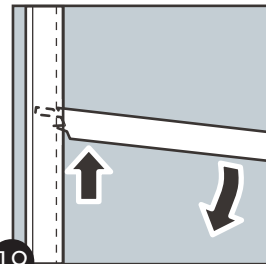

19

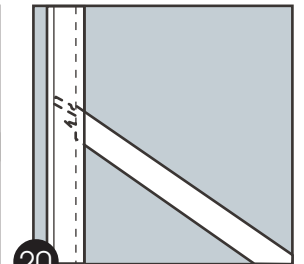

20

the end of the diagonal through the rectangular hole in the vertical (key 17) into the slots in the upright (key 1) inside the vertical (see diagram 21).

- b. Pull upward on the inserted end of the diagonal to make the tabs slide up and lock into position in the slots. At the same time, swing the other end of the diagonal down onto the diagonal bracket (key 4) on the base channel (see diagrams 18 and 19). Very important: as you swing the diagonal down, make sure you apply constant upward pressure on the end of the diagonal brace with the tabs to ensure they stay fully locked in position in the slots.

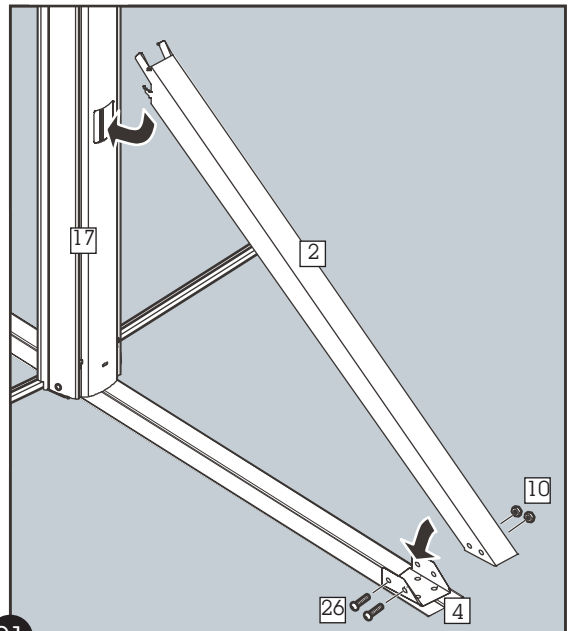

21

- c. Fasten the bottom end of the diagonal brace to the diagonal bracket (key 4) with two 2-1/4" (57 mm) bolts (key 26) and nuts (key 10). Do not overtighten the bolts. They only need to be snug enough to ensure a secure fit (see diagram 21).



**Important:**

Ensure all four tabs at the end of the diagonal are inserted into the slots in the upright.



- d. Fasten the vertical (key 17) which you set in place in step 3(a) to the two vertical clips (key 15 and 16) using two self-tapping screws (key 12).
- e. Repeat steps (a) to (d) for the rest of the buttresses on the straight sides of your pool.

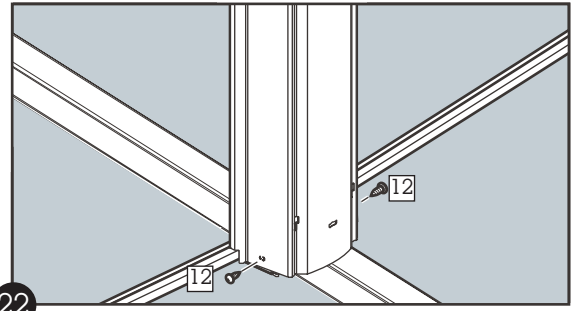

5. Spread out Brick Sand
  - a. Make sure any screw or bolt heads that are to be covered with sand or styrofoam are covered with duct tape first.
  - b. Make sure all of the trenches are completely filled with crushed limestone (or equivalent).
  - c. Spread a layer of fine brick sand (no pebbles) over the foundation area, 2" (5 cm) deep.

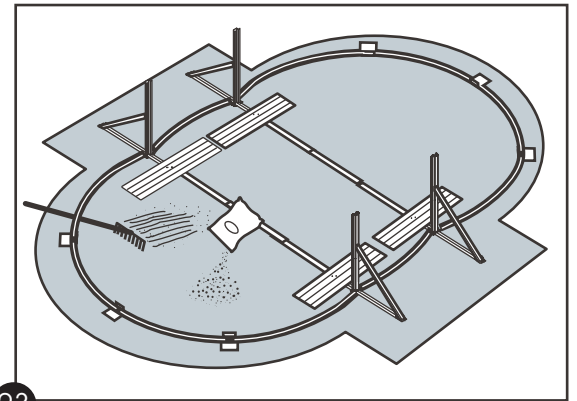

Use a rake to make the brick sand flat and smooth. Instead of brick sand, you can use 1" or 1-1/2" (25 or 38 mm) thick sheets of styrofoam. Cut the sheets to fit. Remove the Styrofoam until the wall is installed. Reinstall the styrofoam sheets and join them with duct tape along the whole length of each seam. Remember to wait until the pool wall has been installed before installing the Styrofoam.

6. Proceed to Section 3
  - a. Continue with Section 3 to assemble your pool. Important: read the Additional Installation Information below before proceeding with the instructions in Sections 3 and 4.
  - b. The last three pages of Section 2 contain information you must use after you finish assembling your pool.

## Additional Installation Information for Section 3

When you come to Section 3, Part A, add the following steps:



**Remember:**  
Do not fill the pool with more than 12" (30 cm) of water until the vertical columns and the top rails are all attached.

- a. It is important that the pool wall be evenly distributed at both ends of the pool to ensure that all the top rails fit. As the wall is uncoiled and placed into the bottom rails it is important to maintain approximately 1/2" (13 mm) gap between the bottom rails or the top rails may not fit.
- b. After the wall is installed, go around the entire pool and make sure all the gaps between the bottom rails are equal in size (the gaps may each finish slightly smaller or larger than 1/2" (13 mm), depending on your pool size). Recheck all of the base plates to make sure each one is centred between the base rails.





- c. After the pool wall has been installed, reconfirm distances to the base plates. Make sure the round ends of the pool have been properly located or the pool wall will not be symmetrical.

**When you come to Section 3, Part A, replace Step 1(d) with the following:**



**Hint:**  
Using a 2" (5 cm) piece of duct tape, tape the ends of the 6" (15 cm) metal slotted tube connector over the slotted tubes and onto the pool wall. This will prevent the slotted tubes from moving during liner installation.



**Hint:**  
Use duct tape at the top of each buttress to temporarily hold the pool wall from falling in before it is properly fastened in place.



**Hint:**  
Secure the slotted tube connector to the wall with a piece of duct tape after installation to prevent it from lifting off the wall.

1. Set the Pool Wall in place

- d. The slotted tubes are colour coded or stamped with a part number. Use the chart below to choose the types and quantities of slotted tubes for your pool (part nos. are shown in brackets under each colour). Set lengths of slotted tube onto the top edge of the wall as you uncoil it and join the slotted tubes with connectors as you go, leaving a 1/2" (13 mm) gap between each. (If you have a beaded pool liner, set lengths of liner retainer on the top edge of the wall first, then the slotted tubes and connectors.)

Pool Size	Quantity and Colour Code (with part nos.)			
	Buttress Tube	Transition Tube A	Transition Tube B	End Tube
12' x 18'	n/a	4 yellow (no. 1470098) (no. 1470012)	n/a	8 plain (no. 1470096) (no. 1470010)
12' x 24'	4 white (no. 1470105) (no. 1470092)	4 blue (no. 1470104) (no. 1470091)	n/a	8 plain (no. 1470096) (no. 1470010)
15' x 24'	2 white (no. 1470105) (no. 1470092)	4 green (no. 1470100) (no. 1470014)	n/a	8 plain (no. 1470097) (no. 1470011)
15' x 30'	4 green (no. 1470100) (no. 1470014)	4 green (no. 1470100) (no. 1470014)	n/a	8 plain (no. 1470097) (no. 1470011)
18' x 33'	4 green (no. 1470100) (no. 1470014)	4 green (no. 1470100) (no. 1470014)	4 green (no. 1470100) (no. 1470014)	6 plain (no. 1470098) (no. 1470012)

(n/a = not applicable; plain = no colour code)

When you come to Section 3, STEP 6, insert the following extra steps 2(f), (g) and (h) after step 2(e):

The 18 x 33 pool is the only size that uses all four types of slotted tubes. Diagram 18 shows the locations for each type.

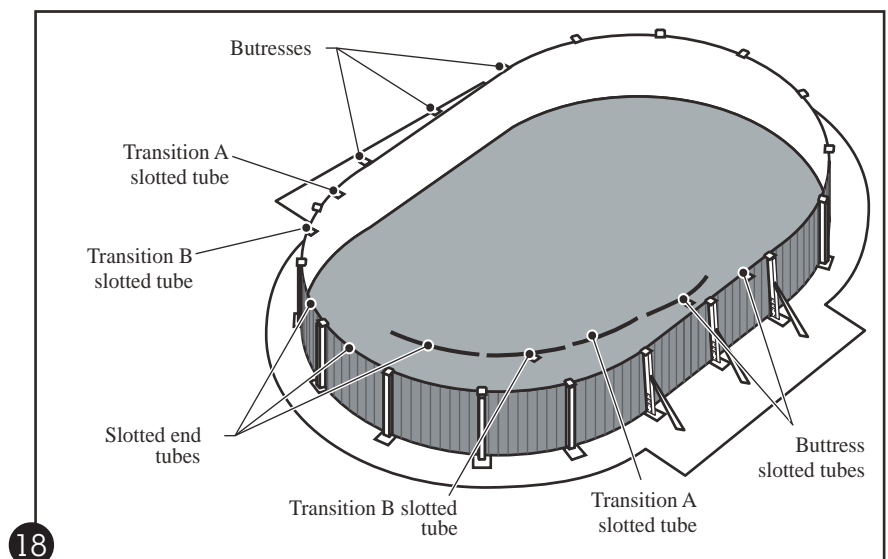

When you come to Section 3, Part A, insert the following extra Steps 2(f), (g) and (h) after Step 2(e):

2. Join the Ends of the Pool Wall

- f. Before proceeding, make sure the pool liner is completely installed and all of the slotted tubes and connectors are in place.
- g. At the top of each butress, make sure the distance between the ends of the slotted tubes on the top edge of the wall is 4" (10 cm). Insert the plastic tube (key A) into the inside of the slotted tubes (key B) to fill the 4" (10 cm) space. The plastic tubes are inserted only in the spaces along the straight sides of the pool where the buttresses are located, not around the round ends of the pool. Make sure the plastic tubes are correctly installed or else when you install the top plates later they will not fit properly.
- h. Where there are no buttresses installed, the space between the ends of the slotted tubes at the tops of the verticals should be about 1/2" (13 mm).

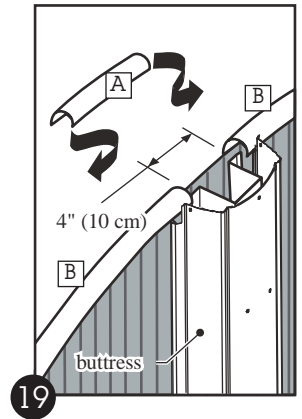

When you come to Section 3, Part A, replace Step 4(a) with the following:

4. Fasten the Liner in place (Beaded Liner only)

- a. When installing the beaded liner retainer the ends must be at least 12" away from any butress or it will be difficult to attach the top plates later. The beaded liner retainer may need to be cut to complete the installation. Important: make sure the segments of liner retainer are put on the top edge of the wall.
- b. Lift the sides of the liner and insert the beaded edge into the liner retainer on the top edge of the pool wall.

When you come to Section 3, Part A, insert the following extra Step 5(c) after Step 5(b):

5. Make a Cove

- c. Along the sides of the pool, each of the buttresses make the wall scallop inward slightly. The cove at the bottom of the wall will be a little narrower and shorter at these points. Make sure the dimensions of the cove where it passes the buttresses match diagram 20 for a correctly shaped cove.

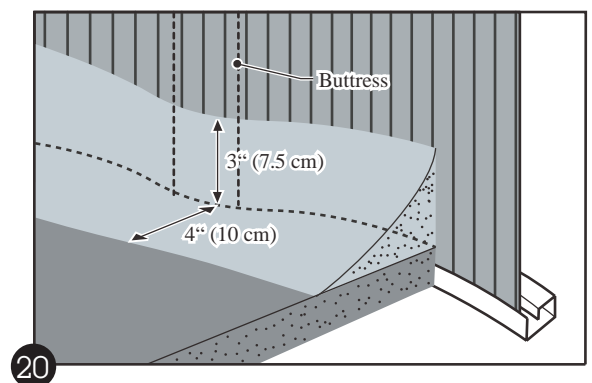

# SECTION 3

## Pool Component Installation Manual

# Assembling the Pool Wall & Liner



### Hint:

Bring the following items onto the pool foundation before you start uncoiling the pool wall: the pool liner, some extra brick sand to make the cove in Step 5, and a ladder to climb out after the wall is assembled.



### Caution:

**Do not** attempt to install the pool wall in the wind. Wait for a calm day.



### Remember:

For **best results**, mount the skimmer on the **downwind** side of the pool (that is, directly across from the most common wind direction).

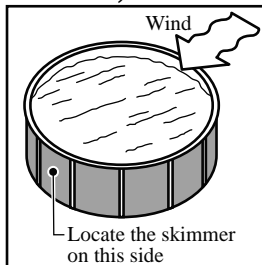

### Hint:

Secure the slotted tube connector to the wall with a piece of duct tape after installation to prevent it from lifting off the wall.

## A. Assemble your Pool Wall

This section is for Round and Oval pools (Round pools are shown).

### 1. Set the Pool Wall in place

- a. Wait for a calm day. **Do not** attempt to install the pool wall in the wind.
- b. Unpackage the coiled pool wall and stand it on a piece of cardboard or plywood at the centre of the pool. The cut-outs for the through-the-wall skimmer should be towards the top of the wall. Look for a "THIS WAY UP" label and arrow.
- c. Start uncoiling the wall, guiding the bottom edge into the curved bottom rail. The starting end of the wall **must** be positioned **over a base plate**, and the skimmer and return holes should be positioned where the pump and filter will be.
- d. Set lengths of slotted tube onto the top edge of the wall as you uncoil it and join the slotted tubes with connectors as you go, leaving a 1/2" (13 mm) gap between each. **Make sure** the gap is directly above the base plate (this applies to round pools, oval pools and Gibraltar Style pools). (If you have a **beaded pool liner**, set lengths of **liner retainer** on the top edge of the wall first, then the slotted tubes and connectors.)

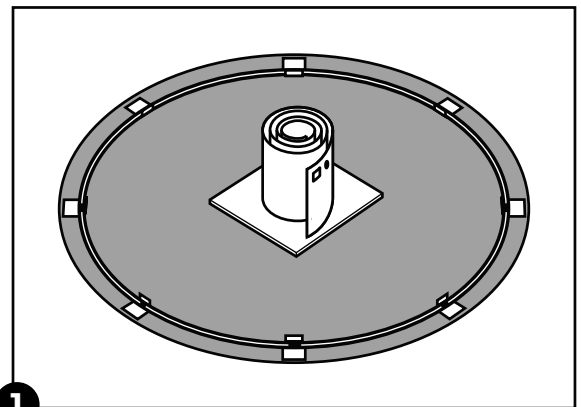

1

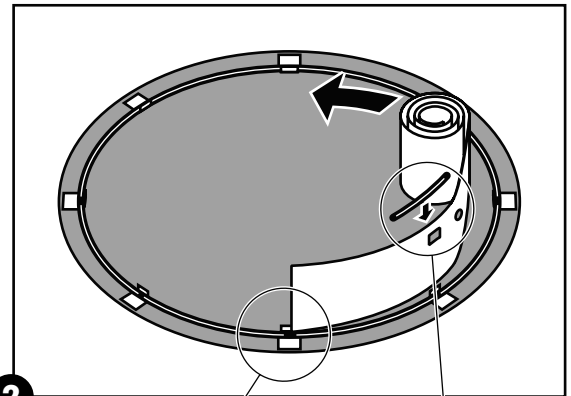

2

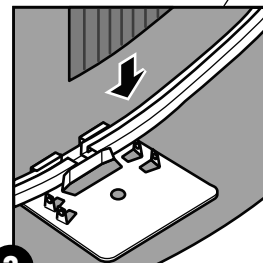

3

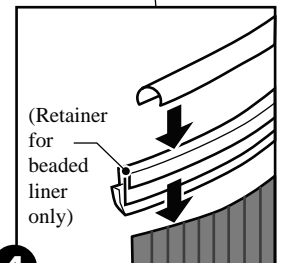

4

- e. Work around the foundation until the entire pool wall is uncoiled into the bottom rails and the top edge is covered with slotted tubes and connectors (and beaded liner retainers if you have a beaded pool liner).



**Hint:**  
Stick a screwdriver through two of the holes to help line up the ends of the wall.

## 2. Join the Ends of the Pool Wall

- a. Line up the holes in the two ends of the pool wall.

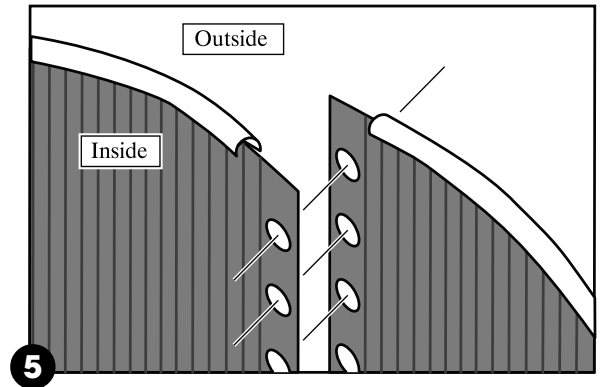

- b. To line up the holes, make the circle bigger or smaller by nudging the base plates in or out with your foot.

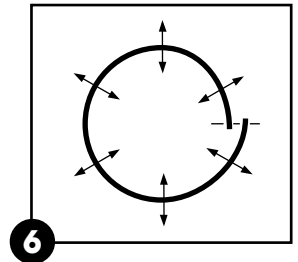

- c. Join the ends of the pool wall with a bolt and nut through each hole. Place each bolt head towards the **inside** of the pool and each nut towards the **outside**.

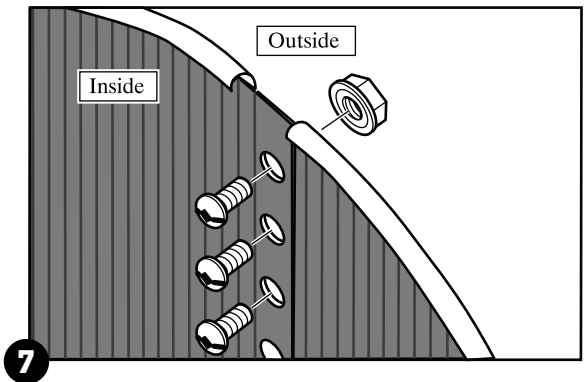

- d. Tighten each bolt and nut securely.

- e. Cover the seam and bolt heads on the inside of the pool wall completely with 2" (50 mm) duct tape.

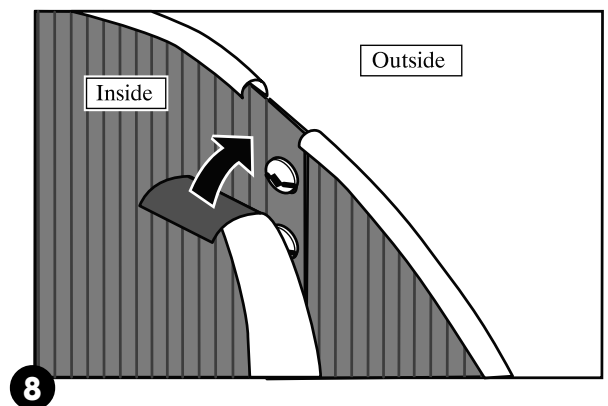

**Remember:**  
The bolt heads must be toward the inside of the pool. Cover the bolt heads with duct tape.

### 3. Make sure the Pool Wall is Level

- a. Use a length of string and a line-level to check across the top edge of the pool wall to see if it is level. Check the wall in several different directions. The wall **must** be level. If the level is off by more than 1" (25 mm) across the diameter of the pool, take the wall apart and level the foundation again.

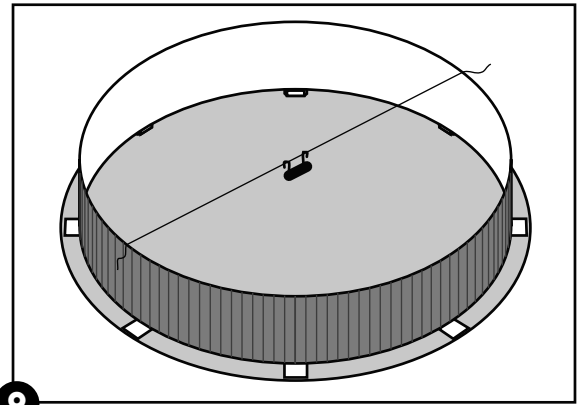

9

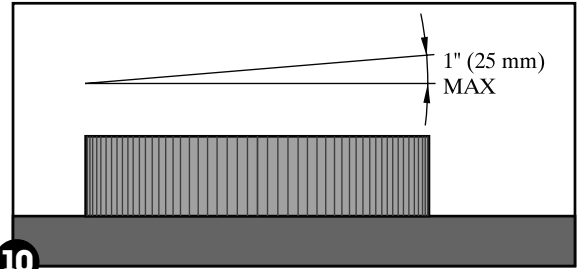

10

### 4. Make sure the Pool Wall is Round

- a. Using a tape measure, measure across the circle at each base plate. The pool wall **must** be round within 1" (25 mm) (all of the measurements must be within 1" (25 mm) of each other). Adjust the circle by nudging the base plates in or out with your foot.

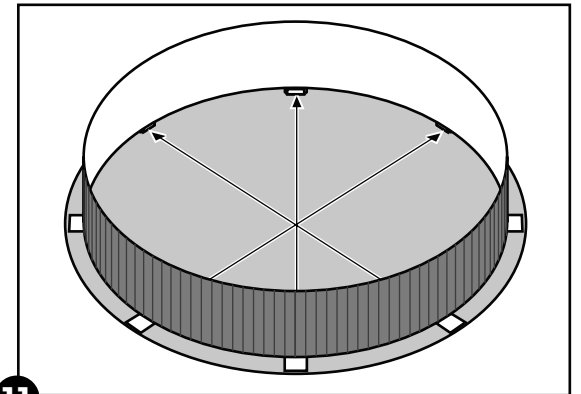

11

- b. Adjusting the pool to the proper shape may cause the base rails and base plates to slip out of alignment a little. Recheck all of the base plates to make sure each one is centred where the base rails meet.

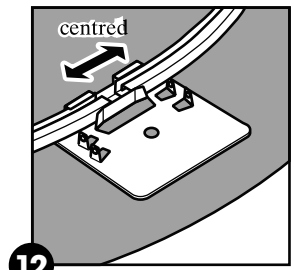

12

### 5. Install the Styrofoam Sheets (optional)

- a. If you chose the option of using Styrofoam **instead** of brick sand, you can now install the sheets of Styrofoam previously cut out in Step 1a. Reassemble the sheets in the centre of the pool and join them with duct tape along the whole length of each seam. Remember to wait until the pool wall has been installed in Section 3 before installing the Styrofoam.



#### Caution:

The pool **must** be level within 1" (25 mm) across the diameter. A pool that is not level is dangerous and may collapse.



**Remember:**

The cove is an important part of the pool structure. Take your time to make a complete, full-size cove.

**6. Make a Cove**

- a. Make a curved cove about 6" (15 cm) high and 8" (20 cm) wide all around the bottom of the pool wall on the inside.
- b. Use fine earth or brick sand to make the cove, and pack it firmly into shape.

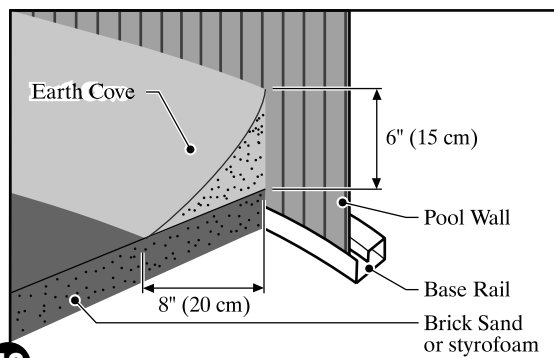

**7. Install the "Wall-Saver" Gasket** 13

- a. The Wall-Saver gasket provides a water-tight seal around the skimmer cut-out for the through-the-wall skimmer. **Gently** spread apart the two layers of the gasket and insert it into the skimmer cut-out so that it sandwiches the wall. **Be very careful not to tear or damage the seam in the gasket or the gasket may leak.** Take extra care not to cut or damage the gasket when you are installing the skimmer later. If the gasket is damaged, you **must** get a replacement from your pool dealer.

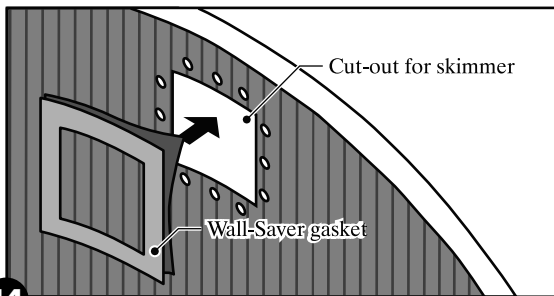

14

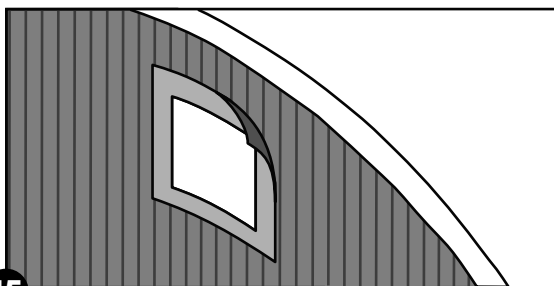

15

**Note: The "Wall-Saver" gasket is not required or provided for walls using 14" skimmers.**

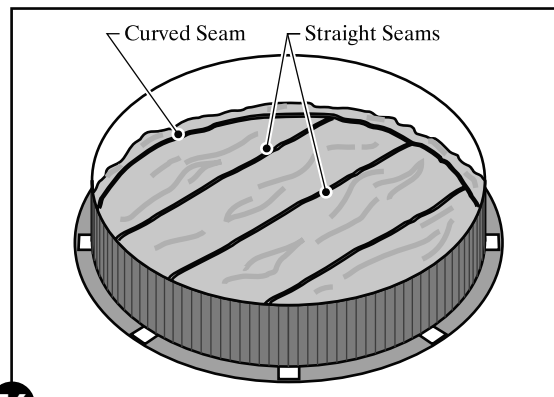

16

**B. Install your Pool Liner**



**Hint:**

If possible, unfold the liner on the grass one to two hours before installation. **Be careful** not to leave the liner too long or you may damage the grass.

**1. Set the liner in place**

- a. Open the carton. **Do not** use anything sharp to open the carton.
- b. Unpack and unfold the liner and spread it out in the sun to warm it up. Inspect all the seams and surfaces for holes.

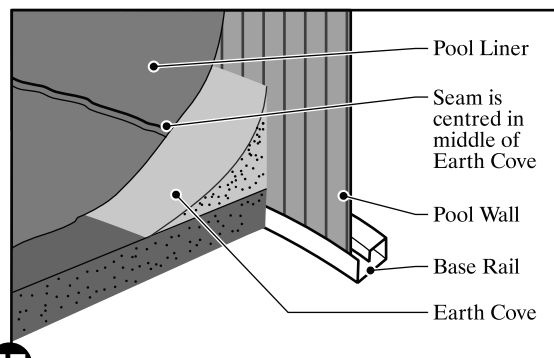

17

**Hint:**

To smooth out the wrinkles in step 2(c), use a **vacuum cleaner**: block the skimmer outlet with cardboard and tape and put the vacuum hose through the skimmer return hole, between the liner and pool wall. Seal the hole with tape and keep the hose 4" to 6" (10 to 15 cm) above the sand cove so you don't suck up any sand. Start the vacuum and run it until most of the wrinkles are gone. Then, stop the vacuum and add 1" (2.5 cm) of water to the pool. Finally, remove the vacuum hose and unplug the skimmer hole.

- c. Spread out the liner, smooth side down. The curved seam should be centred on the cove at the base of the wall. The other seams will form straight lines across the bottom of the pool.
- d. Smooth out all the wrinkles in the bottom.

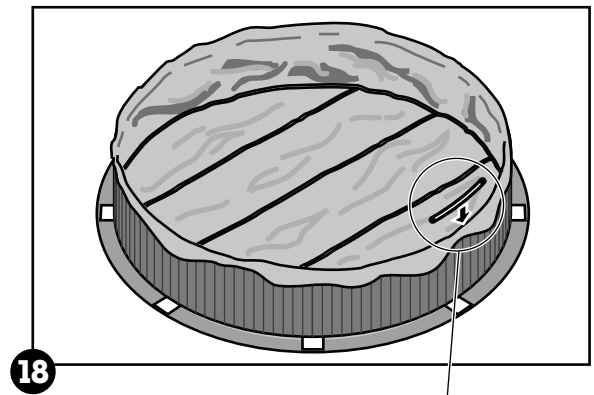
**2. Fasten the Liner in place (Overlap Liner only)**

This step applies only if you have an **Overlap Liner**. See the next page if you have a **Beaded Liner** or **V-Bead Liner**.

- a. Lift the sides of the liner and drape them over the top of the pool wall. If you have a 52" (132 cm) high pool, pull the liner up until there is 2" (5 cm) overhang; if you have a 48" (122 cm) high pool, pull the liner up until there is 6" (15 cm) overhang.
- b. Fasten the liner to the top of the wall with plastic coping. Let the liner hang slack for now. **Do not** pull the liner tight.
- c. Start filling the pool with water. As the pool fills, work out all the wrinkles and smooth the liner to the wall. Remove the plastic coping around the top edge of the wall **one piece at a time** and adjust the liner. Keep smoothing out the wrinkles.

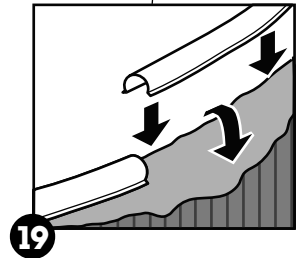
**3. Trim the Plastic Coping and Roll Up the Excess Liner**

- a. After all the wrinkles in the liner are removed, trim any extra length of plastic coping so there is no overlap.
- b. Roll up any excess liner hanging below the plastic coping and tape it in place near the top of the pool wall. **Important: Do not** trim off the excess liner.

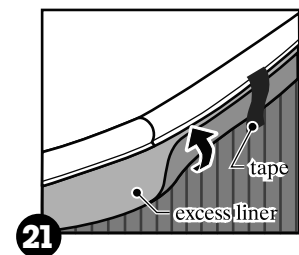
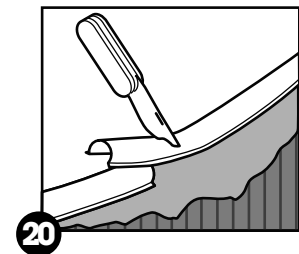
**Remember:**

Do not trim off the excess liner. (If the liner ever needs to be removed, trimming the liner will make re-installation very difficult.) Instead, roll up any excess liner and tape it in place near the top of the pool wall.

#### 4. Fasten the Liner in place (Beaded Liner only)

This step applies only if you have a Beaded Liner. See the previous page if you have an Overlap Liner or below if you have a V-Bead Liner.

- a. Lift the sides of the liner and insert the beaded edge into the liner retainer on the top edge of the pool wall.
- b. Start filling the pool with water. As the pool fills, work out all the wrinkles and smooth the liner to the wall.

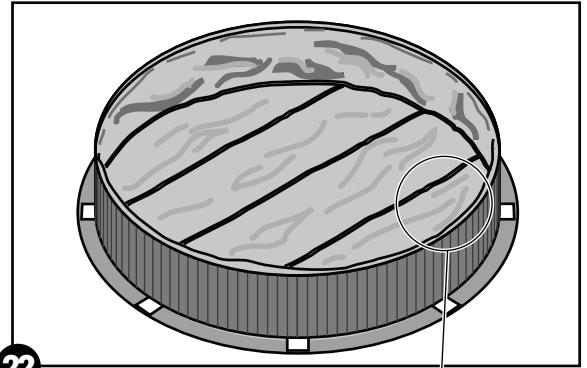

#### 5. Fasten the Liner in place (V-Bead Liner only)

This step applies only if you have a V-Bead Liner. See steps 2 and 3 if you have an Overlap Liner, or step 4 if you have a Beaded Liner.

- a. Remove the slotted tubes and connectors from the top edge of the pool wall. Important: do not remove all of the slotted tubes at once; remove only two lengths of slotted tube at a time.
- b. Hook the V-bead over the edge of the pool wall.
- c. The space between the ends of the slotted tubes at the tops of the locations where the verticals will be attached, should be about 1/2" (13 mm). If you have a Gibraltar Oval System, refer to page 2-6, step 2 in the Gibraltar manual.
- d. Replace the two lengths of slotted tube and connectors.
- e. Repeat steps (a) to (d) until you have gone around the entire pool and finished attaching the pool liner in place.
- f. Start filling the pool with water. As the pool fills, work out all the wrinkles and smooth the liner to the wall.

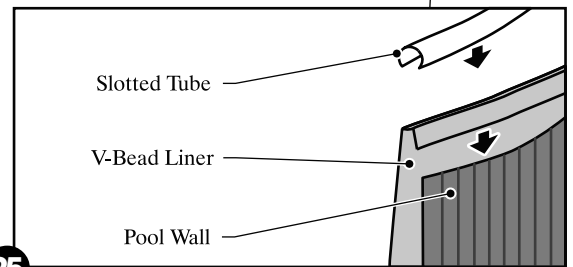
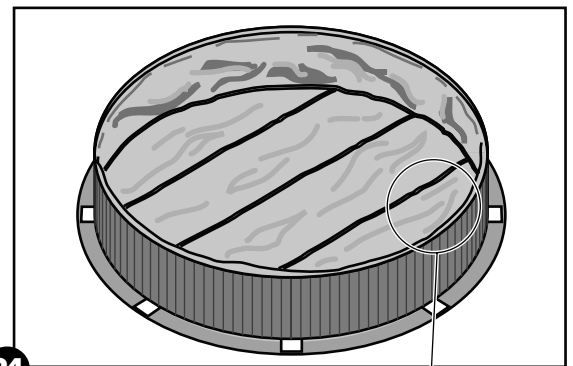
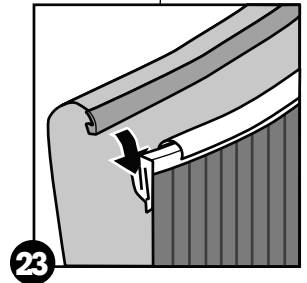

#### 6. Proceed to Section 4

- a. Continue with Section 4 to finish assembling your pool.



# Installing the Top Rails & Verticals

## A. Attach your Verticals and Top Rails

### 1. Continue filling your Pool

- Continue filling your pool with water. Do not put in more than 12" (30 cm) of water until the top rails and vertical columns are all attached.
- Keep working on the top rails and vertical columns while the pool fills.

- See the drawing on the next page for an overview of all the parts used to install the verticals, top rails and top connectors.

### 2. Install the Vertical Columns

- Line up the bottom of one vertical column (key 1) with the two small tabs on one base plate (key 2). The tabs must be on the **inside** of the vertical column. The end of the vertical with three holes must be nearest the top and the end with two holes nearest the bottom.

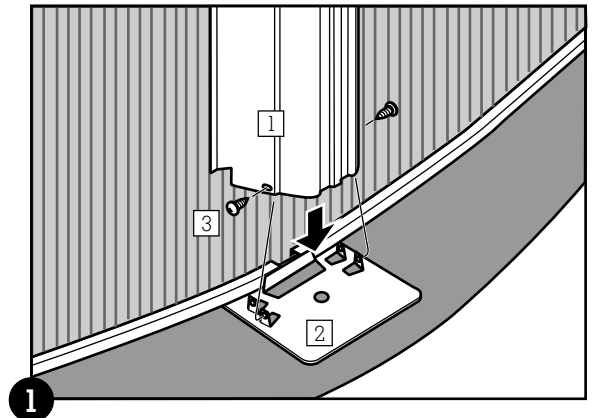

- Line up the screw holes and fasten with one self-tapping screw on each side (key 3).

- Hook a top plate (key 4) over the top edge of the pool wall (key 5). **Important:** Place the top plate down over the top of the vertical column with the front tab on the **outside** of the column and the side tabs on the **inside**. Make sure the vertical column is straight up and down.

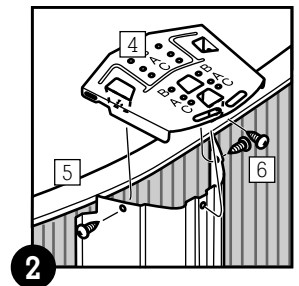

- Line up the screw holes and fasten with one self-tapping screw on each side and one on the front (key 6).

- Repeat the last four steps for each of the vertical columns around the pool wall.



#### Hint:

Use the ridges in the pool wall to make sure the vertical column is straight up and down.

**Overview of  
Vertical, Top Rail  
and Top Connector  
Assembly**

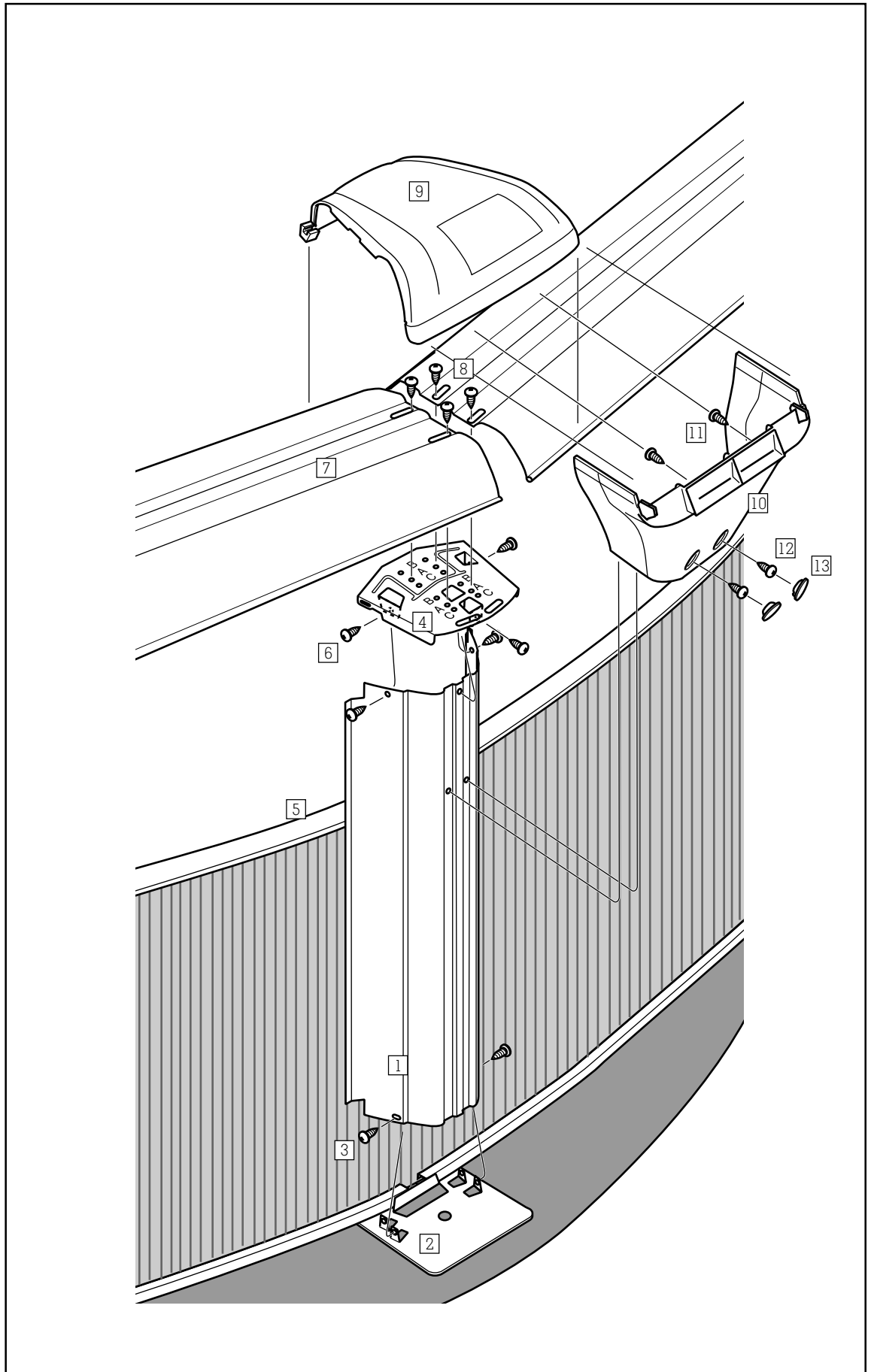

### 3. Install the Top Rails

- a. Place a top rail (key 7) with one end on top of the top plate. The side of the top rail facing the centre of the pool is shorter than the side facing the outside of the pool. The side of the top rail facing the outside of the pool will form a large overhang.
- b. Line up the holes as shown. Fasten through the two oval holes into the holes marked 'A' in the top plate below with two self-tapping screws (key 8). **Do not** tighten the screws yet. Leave the screws slightly loose until all the top rails are in place.
- c. Repeat the last two steps for the other end of the top rail.
- d. Repeat steps (a) to (c) to install the rest of the top rails around the top of the pool wall.
- e. Make the pool settle into a perfect circle by pushing the top of the pool wall **vigorously** inward at each vertical (this will help make the bottom of the pool wall shift into a perfect circle).
- f. Adjust all the top rails to line up evenly with each other and tighten all the screws.

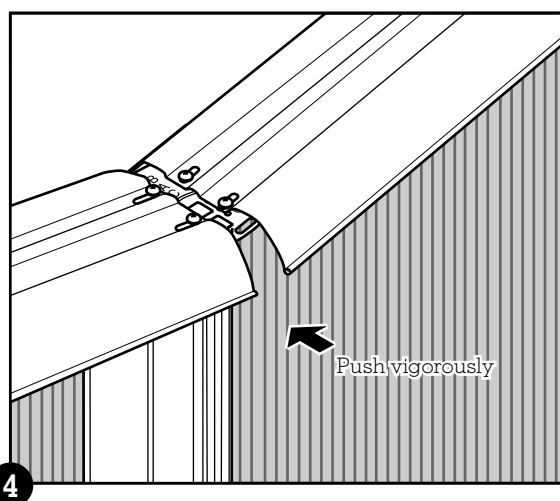
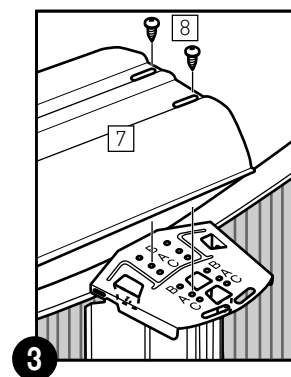

### 4. Install the Top Connectors

- a. Fasten the upper and lower halves of a two-piece top connector (key 9 and 10) with two self-drilling "Teks" screws (key 11). Be sure to hold the two parts together **very tightly** to make a **tight joint** with the two screws.

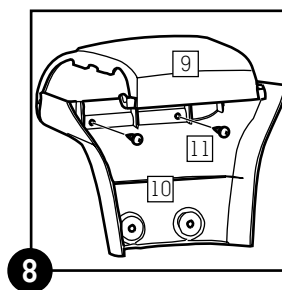
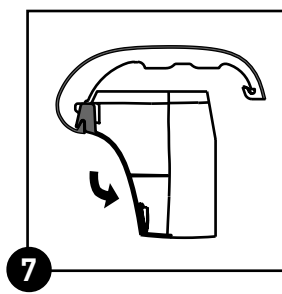
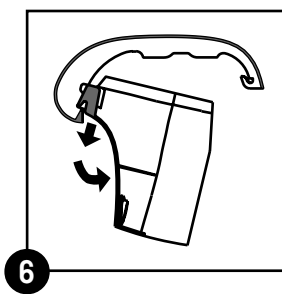
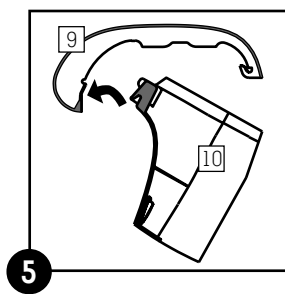

#### Important:

You will find the self-drilling 'Teks' screws in the Top Pack, in package number 1184232. Do not confuse these with the other self-tapping screws.

- b. Line up the assembled top connector (key 9 and 10) above the ends of two top rails.

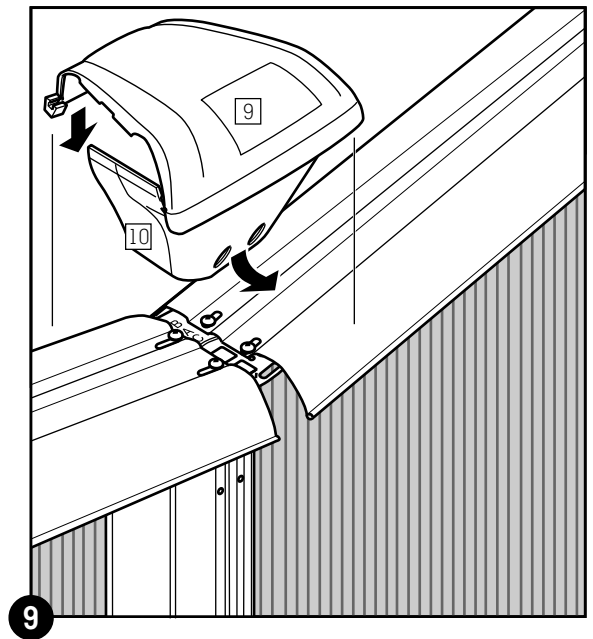

- c. Hook the upper half under the inside edges of the top rails and hold the hooks firmly in place. Bring the lower connector down into place under the top rails by **gently** stretching it across and down, as shown in diagram 10.

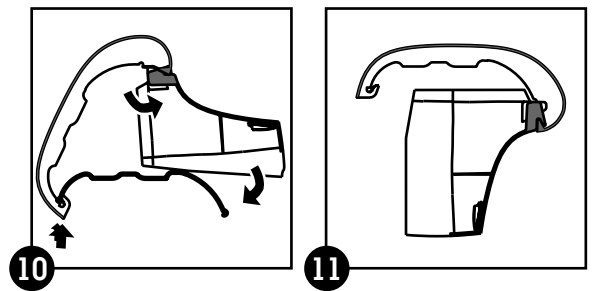

- d. Line up the two screw holes in the lower half connector with the two holes in the vertical column. Fasten the connector in place with two self-tapping screws (key 12). Tighten the screws.

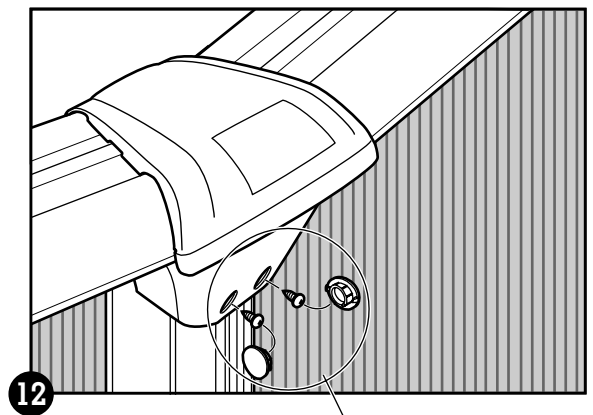

- e. Insert the left (L) and right (R) plugs (key 13) into the holes in the lower half connector (key 10) to hide the screws. Press each plug firmly in place by hooking the smaller tab first into the lower hole, as shown, and then snapping the other tab into place in the upper hole.

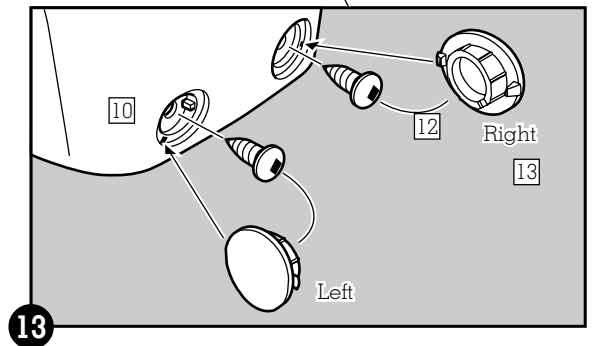

- f. Repeat the last five steps for the rest of the top connectors.



**Note:**

If necessary, the plugs covering the screws can be removed by prying them out with a knife. Be careful not to damage the edges of the plugs.

- g. **For oval pools only:** at the transition points only, where the end rail meets the side rail, make sure the side rail lines up properly with the end rail. If it doesn't line up the connector will appear crooked from above (see diagram 14). If the connector isn't centred between the rails, temporarily remove the connector and loosen the screws on the side rail. Shift the side rail in or out from the centre of the pool until the connector can be properly centred between the rails (see diagram 15).

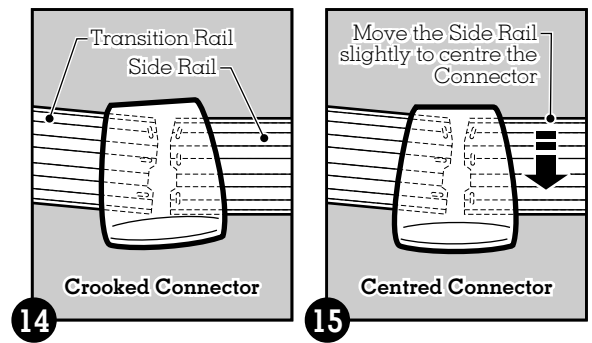

- h. Coat all showing screw heads with clear outdoor varnish.

## B. Fill your Pool with Water



### Important:

The pool wall may bulge and shift a little while filling with water. This is normal.



### Caution:

Before anyone uses your pool, read and follow all the **Safety Rules** in Section 1. This pool is **not** for diving or jumping.

### 1. Finish filling the pool

- a. Fill the pool with water to 2" (5 cm) below the lowest opening. Next, follow the installation instructions for your skimmer.

# Additional Installation Information for Section 4

When you come to Section 4, Part A, replace Step 3 with the following:



## Important:

If the 7" (18 cm) top plate (see diagram 23) is shown in your manual, return to using that manual after installing the transition rails, as described in the Additional Installation Information. Note: the manual included with your pool may show the 6" (15 cm) top plate (shown below), but the 7" (18 cm) top plate (see diagram 23) has been supplied instead. Proceed to step (c) on this page.

6" (15 cm) Top Plate

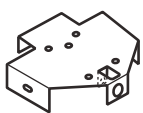

Connectors

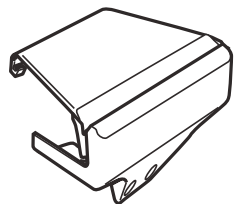
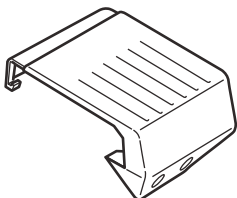

## 3. Install the Top Rails

Note: You must use any additional components that come with your pool and are required for proper assembly as described in your manual Section 4.

- a. Install all the side rails between the buttresses. Use hole 'A' and line up all of the holes as shown in diagram 23. Fasten through the two oval holes to the top plate below with two self-tapping screws (key 9). Do not tighten any of the screws yet. Leave the screws slightly loose until all the top rails are in place. Make sure the verticals are aligned straight up and down (Note: the 12' x 18' pool does not have side rails).
- b. Install the remaining verticals as shown in Section 4, *Installing the Top Rails & Verticals*.
- c. Important: the four transition A top rails are marked with a coloured dot and the ends are mitred. If your pool has connectors that match either of the connectors shown to the left, skip the rest of step (c) and proceed to step (d); if not, then continue with the rest of step (c). Only the end of the transition A top rail that is over a buttress will fasten into the hole marked 'B' in the top plate, as shown in diagram 22. For the rest of the end rails, use hole 'A' and line up all of the holes as shown in diagram 23. Fasten through the two oval holes to the top plate below with two self-tapping screws (key 9).

Do not tighten any of the screws yet. Leave the screws slightly loose until all the top rails are in place.

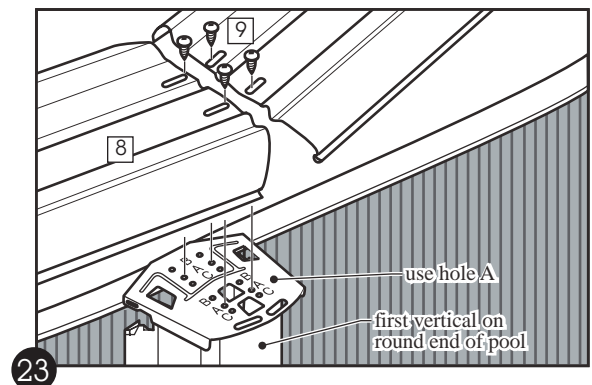
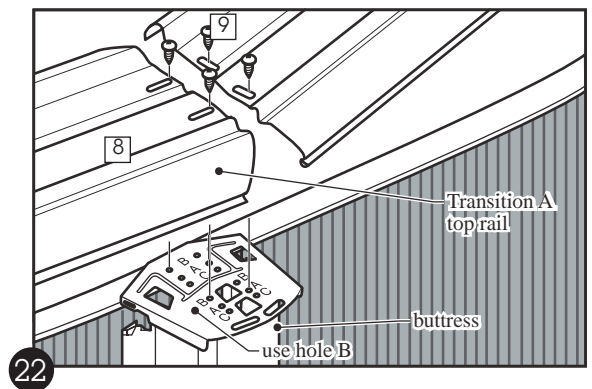
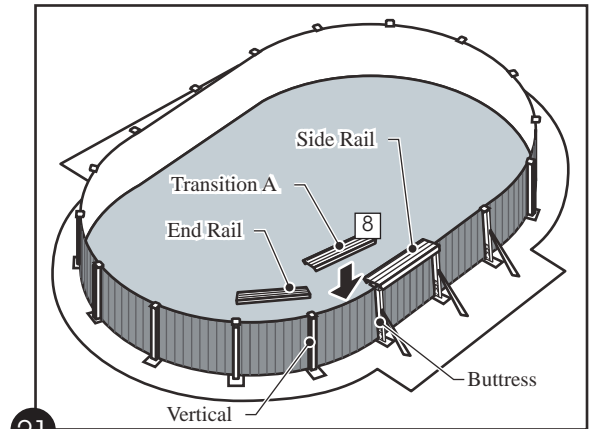

- d. Beginning with one of the transition A top rails, place one end of the rail (key 8) over the top plate at a buttress, and the other end over the top plate at a vertical as shown in diagram 21. (Important: refer back to step (c) to see which holes to use.) The top rail will form a large overhang on each side of the pool wall. Install the end rail as shown in diagram 24. When you install the rails, leave only 1/16" (2 mm) between the ends of the rails. Do not tighten the screws yet because you might need to adjust the rails later.

Important: if any of the verticals are not straight up and down, adjust the base plate and bottom end of the vertical side to side as required by gently tapping on the base plate with a hammer and a block of wood. If you need to adjust the top of the vertical, you may need to remove the top plate first or else the wall and the liner could be damaged.

- e. Check the length of the second transition A top rail before you fasten it. If the end of the transition rail overlaps the side rail, it needs to be cut; if the oval holes of the transition rail do not match the holes in the top plate, you must drill new holes. (Note: the 12' x 18' pool does not have side rails; any overlap will be over the adjacent transition rail.) In the case that the transition rail seems to be too short, you must pull the rails you just installed so the end of the transition rail can be attached to the top plate. The oval holes provide approximately 2" (51 mm) adjustment at each end of the pool.
  - f. Repeat steps (d) and (e) for the other side of the pool.
4. If the transition rail needs to be drilled and/or cut follow these steps:

- a. Temporarily unscrew the end of the side rail that is next to the transition rail. (Note: the 12' x 18' pool does not have side rails.)
- b. Place one end of the transition rail (key 8) underneath the side rail. (Note: for the 12' x 18' pool place one end above the other transition rail.) Place the other end over the first vertical on the round end of the pool and temporarily fasten this end midway of the adjustment provided by the oval holes. If you have a 12' x 18' pool, jump to step (k) now.

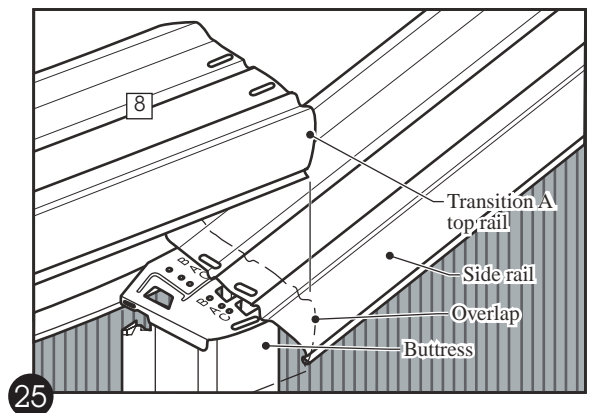
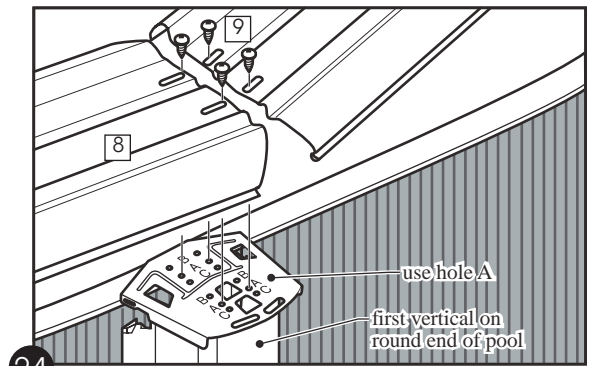

- c. With the end of the side rail on top of the transition rail, mark two dimensions 1/2" (13 mm) and 1-1/8" (29 mm) away from the end of the side rail. Then temporarily unscrew the other end of the side rail and move it to draw the lines **X** and **Y**. The first line **X** is parallel to the end of the side rail, 1/2" (13 mm) away. This will be the line you will cut along to shorten the transition rail. The second line **Y** is also parallel to the end of the side rail, 1-1/8" (29 mm) away. This will be the line that the new 1/4" (6 mm) screw holes lie on.

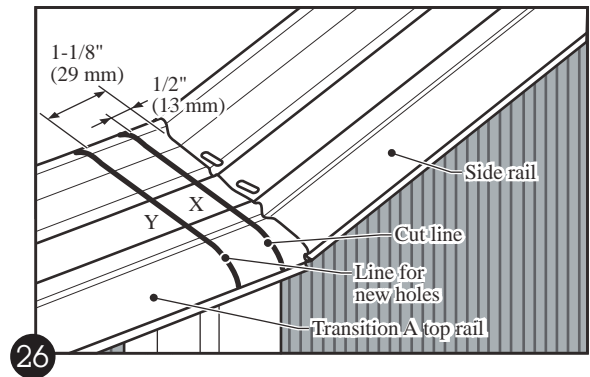

- d. To mark the locations of the 1/4" (6 mm) screw holes, draw two lines through the centres of each of the two oval holes, parallel to the length of the rail, to intersect the line **Y**. The intersection of these lines will determine the locations of the new 1/4" (6 mm) screw holes that need to be drilled.
- e. If your pool calls for a support plate, drill another 1/4" (6 mm) hole 1-1/2" (38 mm) or 2-1/8" (54 mm) toward the inside of the pool along the line **Y**. Measure that distance on your pool.

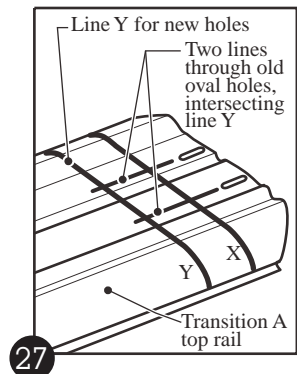

- f. Remove the transition rail and drill the 1/4" (6 mm) holes using the marks that lie on the line **Y**.
- g. Cut the transition rail along the 1/2" (13 mm) line **X** using a hacksaw (use a blade with at least 32 teeth per inch).
- h. Fasten the side rail and the transition rail in place.
- i. Repeat steps (a) to (h) to install the top rails at the other end of the pool.
- j. Continue with the remaining steps explained in your manual Section 4, *Installing the Top Rails & the Verticals*, Part A, under Step 3, *Install the Top Rails*.
- k. If you have a 12' x 18' pool, draw the cutting line **X** along the centre of the top plate where the two transition rails meet. The line **Y** should be drawn parallel to line **X** but 3/4" (19 mm) away from line **X**. To determine the locations of the 1/4" (6 mm) screw holes, follow the above steps (d) to (j).
- l. Continue with Section 4, Step 4 of your manual.





## D. Maintaining your Pool

After you have finished installing your pool, follow these instructions to keep it clean and in good shape.



---

Caution:  
Chlorine can damage your pool liner and metal parts. Wash any spills right away.



---

Remember:  
Any rusty areas on the pool wall must be repainted quickly with anti-rust paint. A badly rusted pool wall can collapse.

1. The Liner
  - a. Check the liner regularly for leaks.
  - b. Minor repairs can be made to the liner with a repair kit.
2. Pool Wall and Vertical Columns
  - a. Keep the pool wall and vertical columns clean. Wash down every so often with mild soap. Do not use abrasives, chemicals or cleansers.
  - b. Wash off any spilled pool chemicals right away.
  - c. Recoat all showing screw heads with clear outdoor varnish.
  - d. Check all metal parts for rust regularly, at least once per season.
  - e. Touch up scratches and rusty area on metal parts with matching anti-rust paint. Follow the directions on the paint can.
  - f. Every two years, lower the water level in your pool to 12" (30 cm) deep. Remove the top edge of the liner from the pool wall and look for hidden rust on the inside of the pool wall. See Section 4 for instructions on removing the liner.
  - g. Pay special attention to any leaks at the skimmer and return openings. Leaks must be fixed immediately.



## E. Winterizing your Pool

At the end of the swimming season, you must follow these directions to make your pool ready for the winter.



---

### Caution:

Do not drain all the water from your pool for the winter, and do not remove the liner. An empty pool can collapse in the winter.



---

### Remember:

Failure to install the "Pool Winterizing Kit" and follow the winterizing procedures, in accordance with these instructions, may void the pool warranty.

### 1. Lower the Water Level

a. Lower the water level in your pool until it is about 6" (15 cm) below the water return fitting.

b. Remove all hoses attached to the skimmer and return fittings. Make sure all water is drained from the skimmer housing, and make sure the hole at the bottom of the skimmer is left UNPLUGGED.

### 2. Check all Joints and Screws

a. Make sure all the frame joints are fitting together properly and make sure the pool wall has not shifted from the bottom rail.

b. Make sure all screws and bolts are tight.

### 3. Check for Rust

Paint any scratches or rusty areas with anti-rust paint.

### 4. Check the Liner

Make sure the top of the liner is still attached to the pool wall with plastic coping. Do not remove the liner from the pool. Removal of the liner will void the existing warranty. Do not drain all the water from the pool for the winter.

### 5. Finding Leaks

Make sure the liner has no leaks. Check the liner for leaks and repair any holes with a vinyl patch. Leaks in the winter can cause severe damage to your pool.

### 6. Pool Accessories

Remove all pool accessories from the pool, including the ladder. Leave the skimmer attached to the pool wall. Ensure that the skimmer lid is installed and the opening at the bottom of the skimmer is open so that accumulated water can drain immediately.

### 7. The Filter

Disconnect the hoses from the filter. Follow the winterizing instructions in your filter manual.



# Important Winterizing Notice

## All Pools:

The water level must be maintained at least 3" (76 mm) below the skimmer opening throughout the winter. Surplus water must be removed by pumping, draining or siphoning so that it doesn't enter the skimmer during the winter. Remove all hoses attached to the skimmer and return fittings. The opening at the bottom of the skimmer **MUST** be kept open so that accumulated water can drain immediately.

## Pools with 12" (30 cm) skimmers:

In addition to the above, the Pool Winterizing Kit (Part Number 1370138) must be inserted into the 12" (30 cm) skimmer (see illustration below).

Failure to install the "Pool Winterizing Kit" and follow the winterizing procedures, in accordance with these instructions, may void the pool warranty.

The Pool Winterizing Kit (Part Number 1370138) is also available from your pool dealer.

## All Pools:

Do not attach the pool cover to the top rails, verticals, connectors or any part of the skimmer.

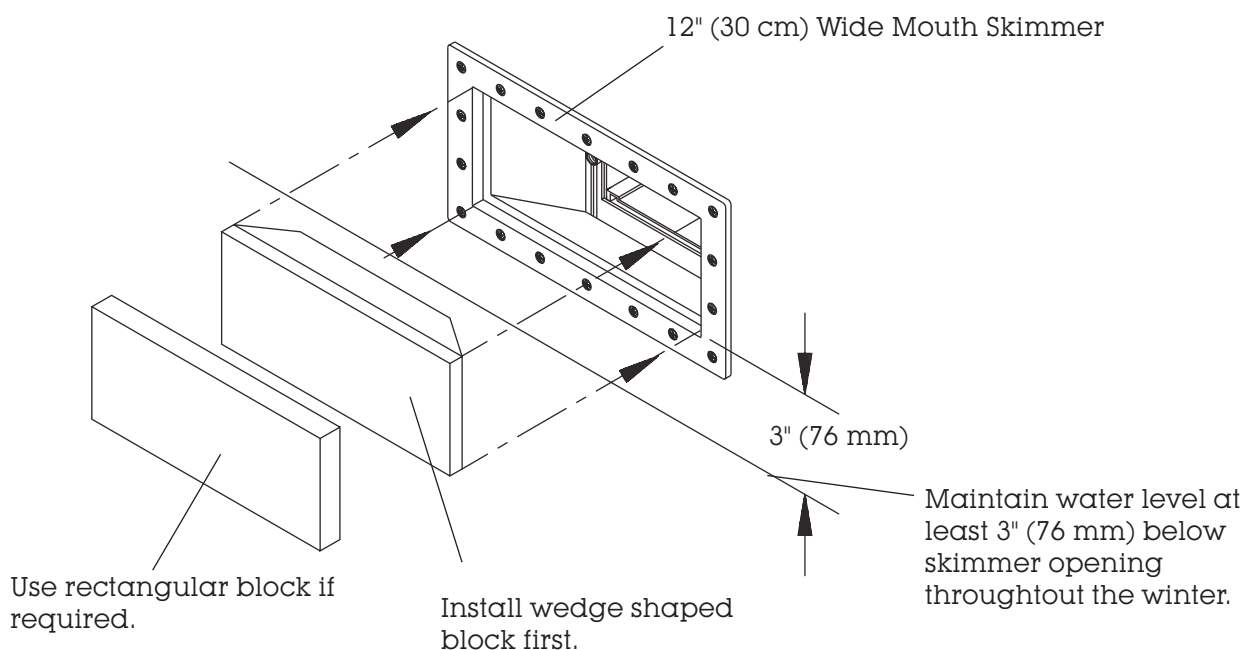

## Installation:

### "PAWS" Skimmer:

1. Force the wedge shaped block into the skimmer opening until it sits flush with the face flange.

### Other Skimmers:

1. Place the wedge shaped block into the skimmer throat.
2. Force the rectangular shaped block into the skimmer opening until it sits flush with the face flange.

### Note:

On some skimmers, it may be necessary to trim the foam to make a friction fit and/or use a wooden wedge to keep it in place during the winter.

