

3 INCH RANGE POLE SET ASSEMBLY:

- Loosely assemble extruded tubes together. Slide excess width into adjoining tubes, dividing it up as equally as possible.
Note: You must have a minimum of 9" of overlap in each tube!
- Measure the width across the pool from plug surface to plug surface & adjust length of the tube assembly to fit the span.
- Lock the tubes together by rotating each adjoining tube in the opposite direction. (See Figure C)
- Secure each tube with just 1 self drilling screw in each adjoining tube.
- Attach the tube assembly into the Crank and Tubing Plugs and check for fit. Assemble Tube assembly together with Crank Handles and Tube Plugs by lining up hole in the end of each tube fitted into Crank Handle and secure with metal Axle Bolt and nut provided.
- When all is OK drill and screw the remaining screws at each end of the overlapped poles. You should have 6 screws on each tube end where there is a connection.

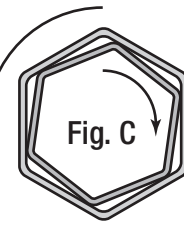

Twist Tubing To Remove Excess Play Prior To Screwing Together.

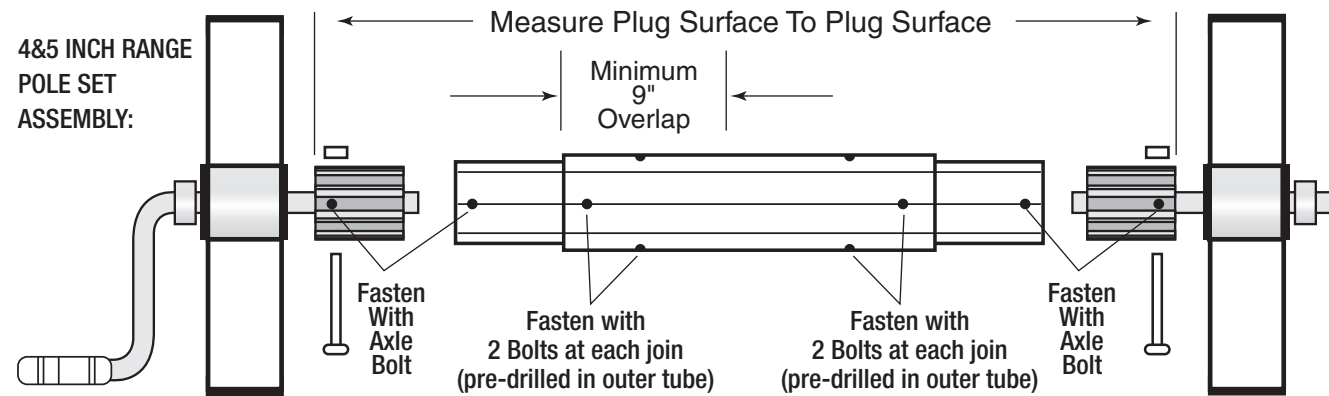
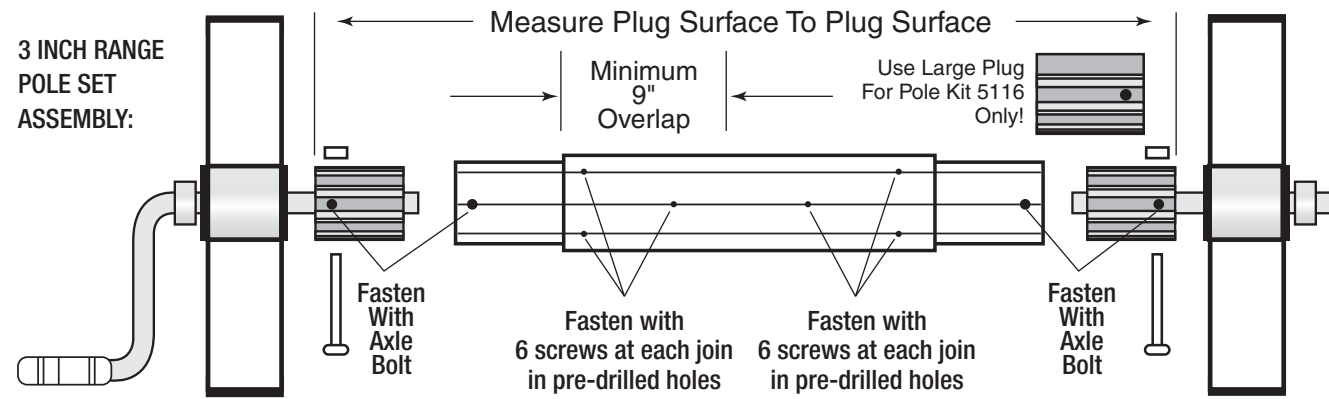

4&5 INCH RANGE POLE SET ASSEMBLY:

- Follow instructions as above except...
- When all is OK drill through holes in large outer tubes using pre-drilled holes as a template. Drill from each side with Drill Bit supplied.
- Fasten with 2 Bolts & Nuts at each joint. Bolts are at right angles to each other

9. Attach Straps to Tubes:

Come in 6 inches from each tube end and attach a strap plate to the aluminum tube assembly. Use the self drilling screws on the drill line to attach the plate. Look at the holes that were pre-drilled at the factory and use the same drill line. There are 6 lines on each tube. Take the remaining strap plates and connect them evenly along the length of the tube assembly. Attach Straps to strap plate. (See Figure D)

10. Attach Solar Blanket to Straps:

If Wheel is to be placed at the end of the pool, attach cover to strap plate with plastic screw as shown in Figure Below Left. If Wheel is to be placed in offset position, then attach cover to strap plate forming a fold to act like a hinge and the plastic screw will go through two layers of the solar blanket as shown in Figure F Below Right. Bubbles should face down.

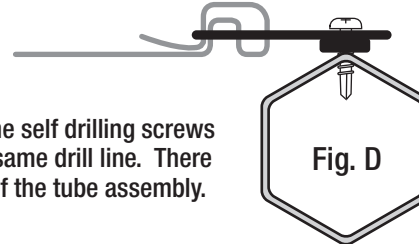

Thread Strap as Shown

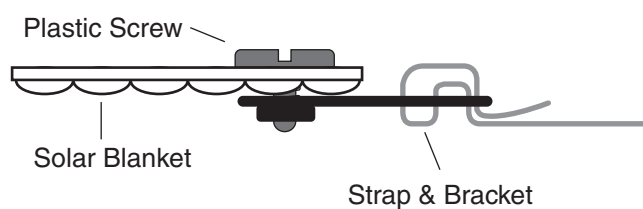

Fig. E

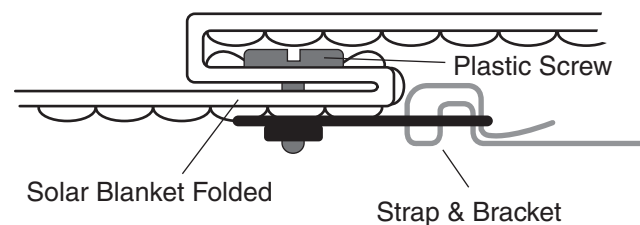

Fig. F

Item #55000 Instructions

SWIMLINE®

HYDROTOOLS™

Solar Reel™

Commercial Reel System
For In Ground Solar Pool Covers
12" Fixed Height



HYDROTOOLS
by ILP/Swimline

Edgewood, New York 11717 • www.swimline.com

SWIMLINE®
HYDROTOOLS™
Solar Reel™

Item # 55000
**Commercial Reel System
 For In Ground
 Solar Pool Covers**

1. Congratulation on your purchase of our Swimline Hydrotools Commercial Quality Solar Reel™ for In Ground Pools. Please follow the instructions carefully so as to not void our warranty.
2. Please use your solar blanket and reel assembly in the manner it was intended for:
 - a. Your solar blanket is not a safety cover
 - b. Remove the solar blanket and Solar Reel™ assembly from the pool completely before swimming use.
 - c. Do not store the solar blanket on the ground in direct sunlight, as it will burn the lawn
3. Preparation & Assembly: Check inventory of all items and assemble as illustrated below:

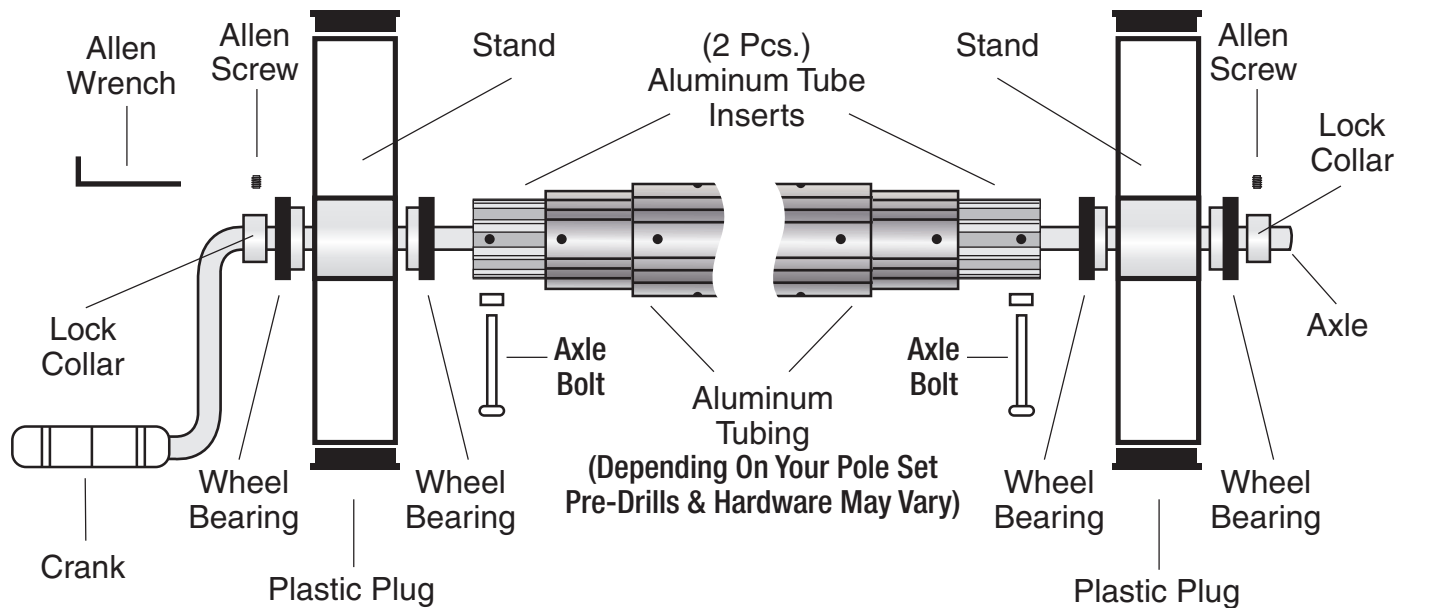

- PARTS LIST**
- 2) Adjustable height stands
 - 4) Sealed bearings (installed)
 - 4) Plastic end caps for stands
 - 1) Crank handle with grip & lock collar
 - 1) Axel with lock collar
 - 2) Aluminum tube inserts
 - 2) Axle Bolts with nuts
 - 1) Allen key for locking collar
 - 4) Rubber feet with attachment hardware

- STRAP KIT**
- (11 Pcs.) Plastic Screw (1 extra piece)
 - (21 Pcs.) Plastic Strap Plate (1 extra piece)
 - (11 Pcs.) Stainless Steel Self-Drilling Screws (1 extra piece)
 - (1 Pc.) Phillips Screw Gun Bit
 - (10 Pcs.) Fabric Straps (1 extra piece)

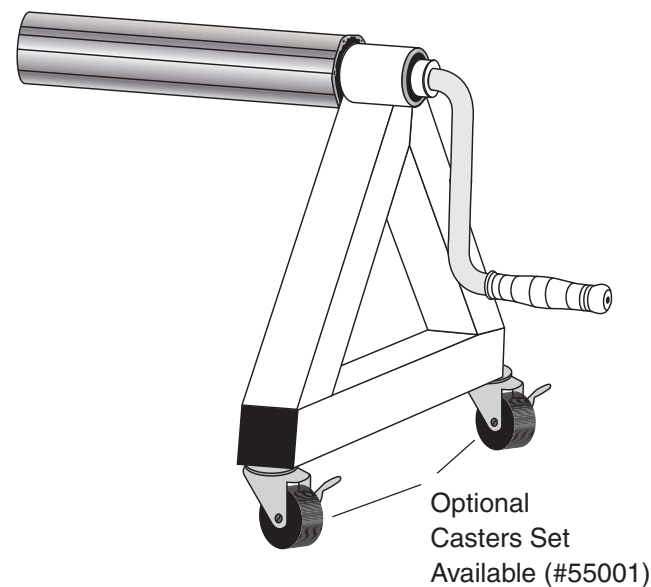

4. Depending upon the size of your pool you will also require one of the following pole sets:

STANDARD POLE SETS:

Item #5112: 3" Diameter
 Fits up to 12' width pool
 (3) Piece Set, (13) SS Screws

Item #5116: 3" Diameter
 Fits up to 16' width pool
 (3) Piece Set, (13) SS Screws

Item #5120: 3" Diameter
 Fits up to 20' width pool
 (5) Piece Set, (25) SS Screws

HEAVY DUTY POLE SETS:

Item #51160: 3" Diameter
 Fits up to 16' width pool
 (3) Piece Set, (4) 3.25" Axle Bolts

Item #51200: 3" Diameter
 Fits up to 20' width pool
 (5) Piece Set, (8) 3.25" Axle Bolts

HEAVY DUTY POLE SETS FOR HEAVY WEIGHT COVERS:

Item #51164: 4" Diameter
 Fits up to 16' width pool
 (3) Piece Set, (6) 4" Axle Bolts
 (2) 4" Aluminum Tube Inserts

Item #51204: 4" Diameter
 Fits up to 20' width pool
 (5) Piece Set, (10) 4" Axle Bolts
 (2) 4" Aluminum Tube Inserts

Item #51205: 5" Diameter
 Fits up to 20' width pool
 (5) Piece Set, (10) 5.5" Axle Bolts
 (2) 5" Aluminum Tube Inserts

5. Positioning Your Solar Reel:

For Rectangular pools, place Stands at either end of pool.

For Irregular shaped pools, place Stands at some convenient midway point. You will need to fold Blanket and allow Blanket to unroll in two directions. (See Figure A below)

Fig. A

RECTANGULAR



IRREGULAR

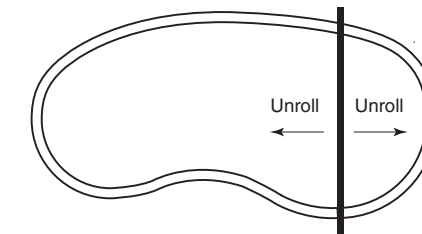

6. Trimming Your Solar Blanket:

- Lay your Solar Blanket (not provided) on top of water. **IMPORTANT!** Irregular Shaped Pools will need to have their solar covers folded at point of placement of Stands! The cover will unroll left and right of Stands & cross pole. Please allow 6 inches more material on length to allow for a fold where straps will be attached for wind onto reel system. (See Illustrations above)
- With scissors trim blanket to fit shape of pool. Be sure to clear pool edge coping.

7. Assembling The Cross Poles:

All Tube Sets consist of 6 sided Hexagon shaped aluminum tubing. In the 3 Inch range, there are two diameters of tubing, 2.745" and 2.920", the smaller size nesting into the larger size. The 12' and 20' Tube Kits Begin and End with Small Aluminum Tube Inserts therefore requiring Small Aluminum Tube Inserts at either end. The 16' Tube Kit Begins with a Small Aluminum Tube Insert and Ends with a Large Aluminum Tube Insert therefore requiring a Small Aluminum Tube Insert at one end and a Large Aluminum Tube Insert at the other end. The Large Tube Plug is self-aligning. The small Aluminum Tube Insert requires **CAREFUL ALIGNMENT!** (See Figure B Below For Proper Alignment)

Fig. B

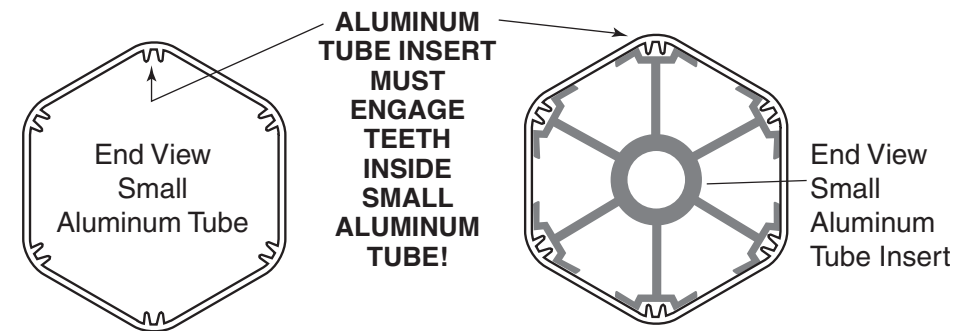

8. For 3 inch range pole sets, you will use a series of pre-drilled holes, spaced approximately 1-1/2" and 7-1/2" inches from each end, to join the large tubing to the small tubing. These holes are space 120 degrees apart. At the appropriate time you will secure with self-drilling and tapping SS screws. Also take note of large holes that pierce both end tubes. You will eventually use these holes to anchor tubing to Crank Handles with Axle Bolts provided.