



1-866-778-POOL

www.poolboyproducts.com

POOL BOY® Powered Solar Blanket Reel

Pool Boy 1A & Pool Boy 2A Installation / Operation Guide

Revised 12/23/2019



INTRODUCTION

Please Read, Follow, and **Save this Instruction Manual.**

POOL BOY® is a powered swimming pool solar blanket reel system; it features an adjustable height and remote control.

POOL BOY II ® is a powered swimming pool solar blanket reel system; it is non-adjustable in height and includes a remote control.

POOL BOY® is recommended for use on rectangular shaped pools with or without diving boards.

The POOL BOY® system should only be used for the intended application.

IMPORTANT SAFETY PRECAUTIONS



READ AND FOLLOW ENTIRE INSTRUCTION MANUAL AND ALL PRECAUTIONS. SAVE THIS INSTRUCTION MANUAL FOR YOUR RECORDS. PRIOR TO INSTALLING, USING, OR TROUBLESHOOTING THIS EQUIPMENT

CAUTIONS

- Read, Follow, and **Save the Entire Instruction Manual.**
- Use the system only in the intended manner.
- Remember, solar blankets are not safety covers.
- Remove the solar blanket completely from the pool before using the pool.
- The POOL BOY® system is intended to be stationary. It is not designed to be mounted on a caster-equipped stand.
- Visually inspect the pool prior to retracting or extending the solar blanket. Ensure that the pool is clear of occupants and that no items will conflict with the solar blanket.
- Store the remote control and system key in a secure location in order to prevent unauthorized operation.
- Unit is for outdoor use only.
- Do not attempt any technical repairs without proper training or first calling Pool Boy Technical Support at 1-866-778-POOL(7665). Failure to do so may result in Denial of warranty claims.

WARNING- RISK OF ELECTRICAL SHOCK

To reduce the risk of electric shock, observe the following precautions.

- Connect the power supply only to a grounding type receptacle protected by a class A Ground Fault Circuit Interrupter (GFI).
- Install power supply at least 10 feet (3.1 M) from the inside walls of the pool and at least 1 foot (30cm) above the ground / deck level.
- Do not use with an extension cord.
- Replace damaged cords immediately.
- Disconnect electric power before servicing.

GETTING STARTED

Required Tools

- Drill/driver/screw gun with 5/16 hex driver bit
- 25 foot tape measure
- Flat blade screwdriver
- 5/16 & 7/16 wrenches or sockets

Select the Location

Select a location at one of the narrow ends of the pool. The location must:

- Be away from the ladder
- Have access to a GFI protected 120V AC receptacle.
- Provide a mounting location for the power supply
- The drive side stand may be placed on either side of the pool

Suggested Layout

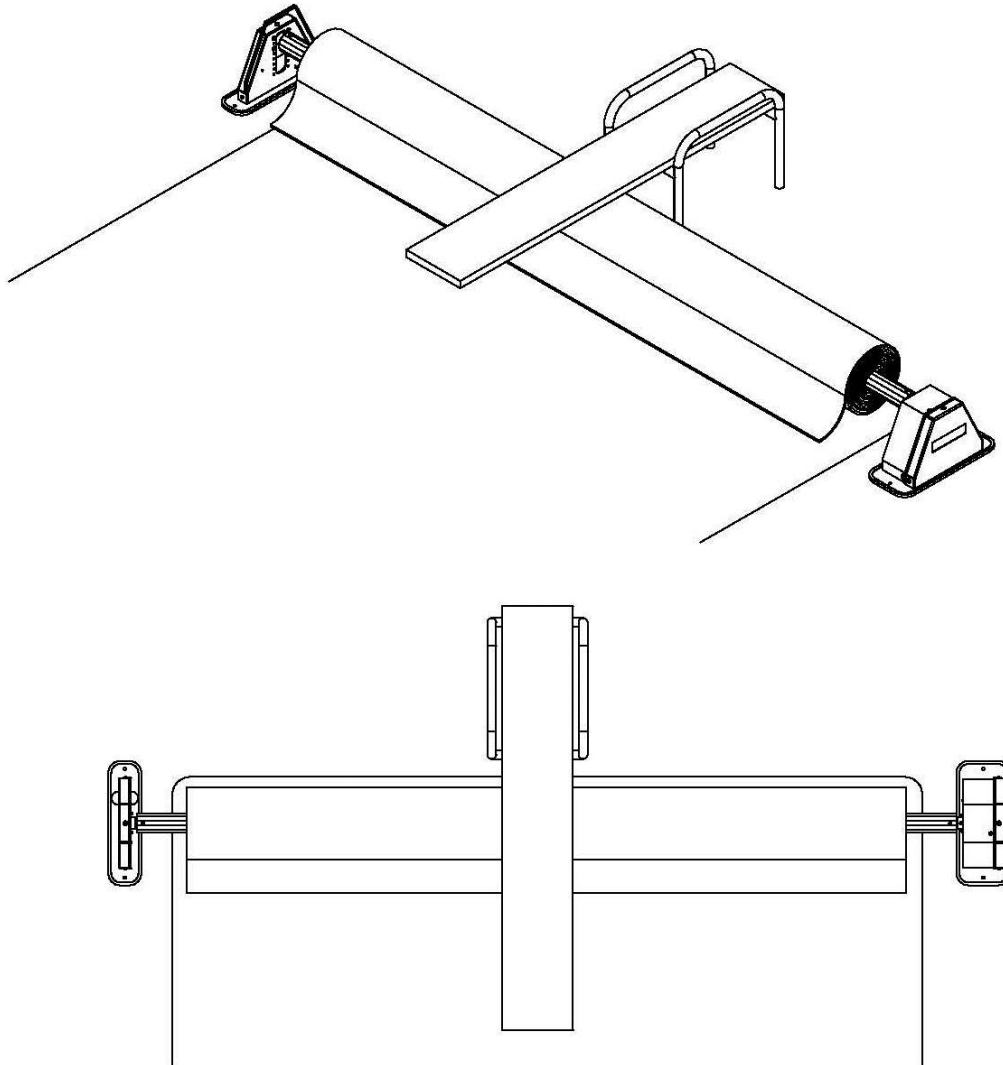

Pool Boy® (Adjustable Height)

Pool Boy® II (Non-Adjustable)



Installation

1) Position the Stands

Position the stands in the selected location at one of the narrow ends of the pool. The stands come fully assembled in the middle of the height adjustment range (Not applicable for Pool Boy® II).

If height adjustment will be required, remove both standcovers.

Height adjustment

The height of the POOL BOY® reel system is adjustable through a wide range. The height of the cross tube can be changed by moving the hub assemblies to different height settings.

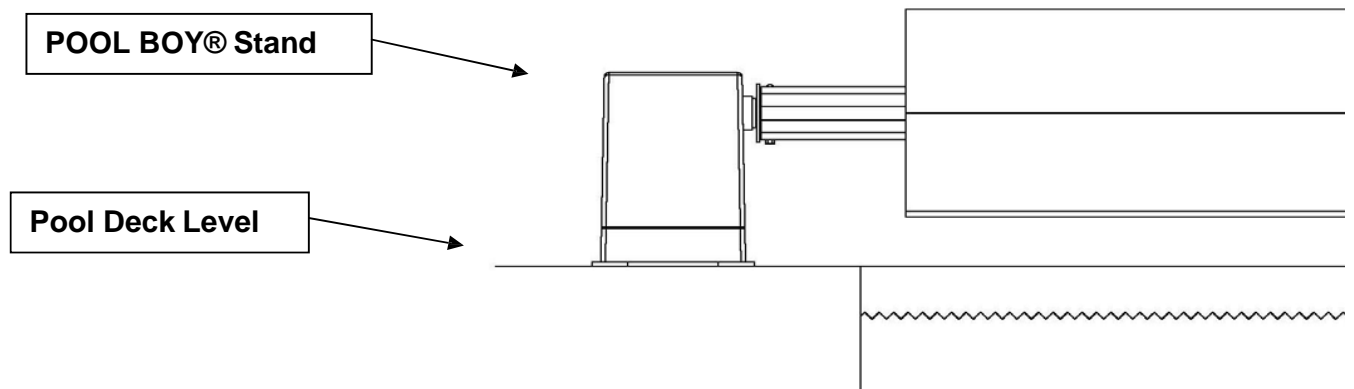

Example- Highest Setting

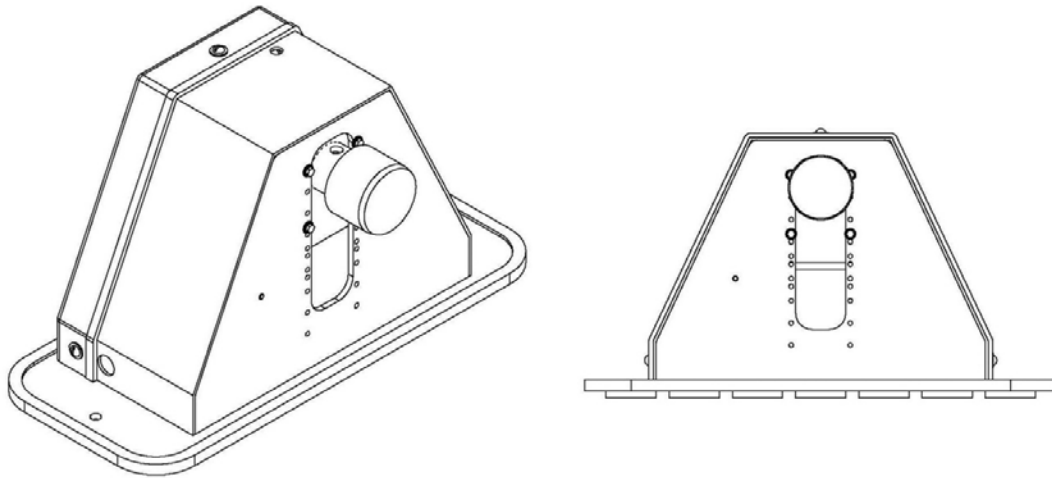

Example- Lowest Setting

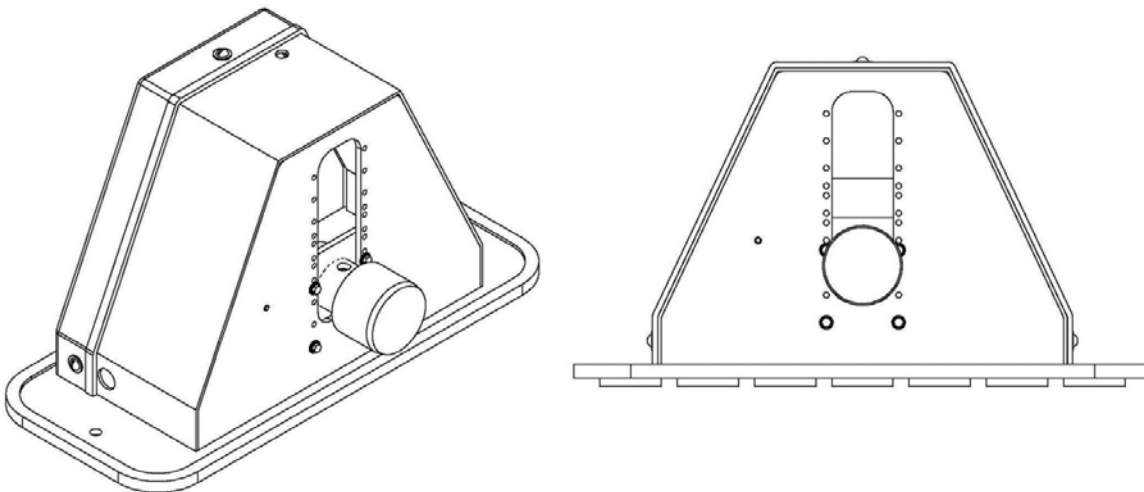

Adjusting Pool Boy® Stand Height

Remove the motor and idler stand covers. The covers are held in place by three screws. Using the 5/16" wrench, remove bolts that attach motor case to stand. Position motor / gearbox assembly at the desired height. Insert and tighten bolts. Care must be taken not to over tighten the motor mount bolts.

Position hub on the idler stand to the same height. Using two 7/16" wrenches, remove bolts that attach the idler hub and position hub to match the motor stand hub location. Reinstall bolts and tighten.

Leave the motor stand cover off. Install the idler stand cover, if desired.

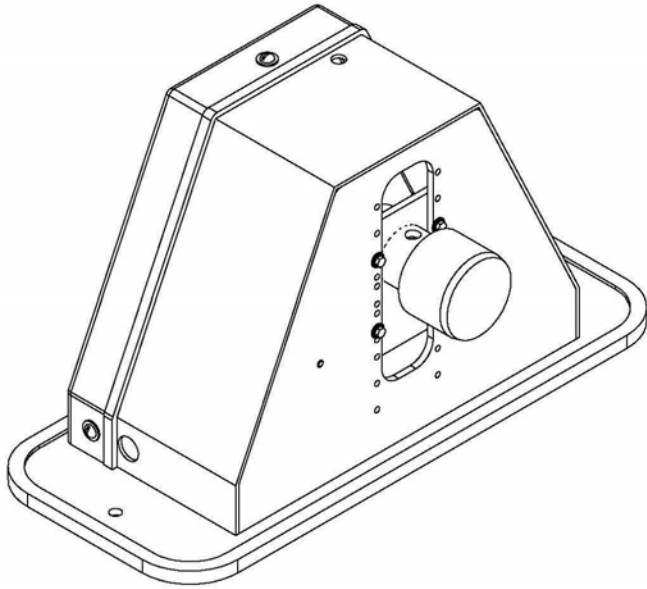

Using a 5/16 wrench,
remove (4) mounting bolts.
Adjust stand height and
reinstall bolts.

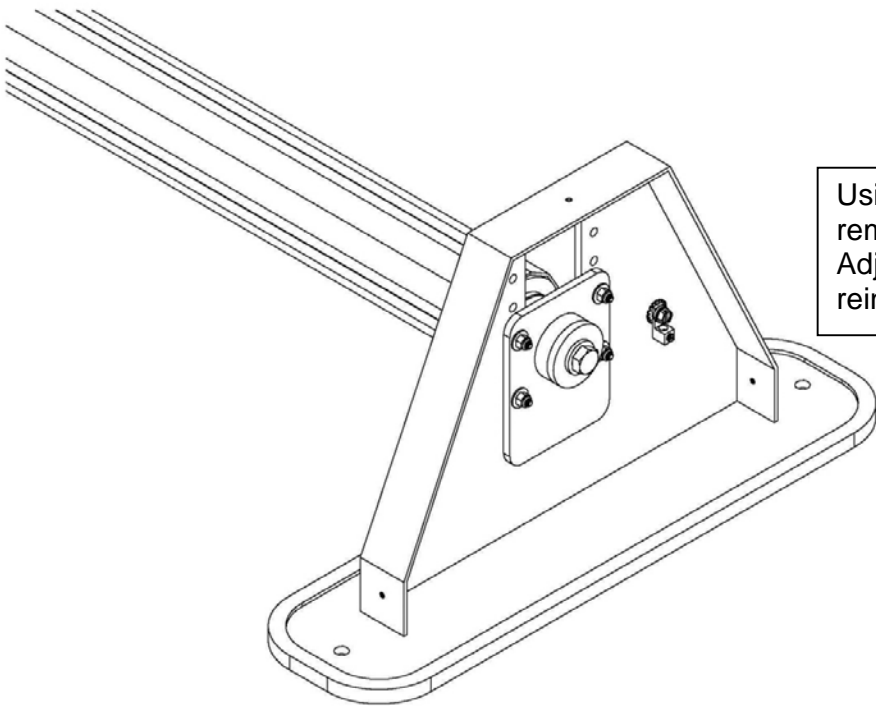

Using two 7/16 wrenches,
remove (4) mounting bolts.
Adjust stand height and
reinstall bolts.

2) Tube Assembly - Twist Locking Tubes

The tube assembly is adjustable to accommodate required widths from 17' to 21'10". The tube assembly has three tube sections. Two smaller diameter tubes telescope from each end of the larger diameter tube. See the drawings along with the below instructions. Do not exceed the maximum lengths shown on the drawing. When installing and tightening screws care should be taken to avoid stripping or breaking the screws. The use of a drill/driver with a slip clutch is highly recommended.

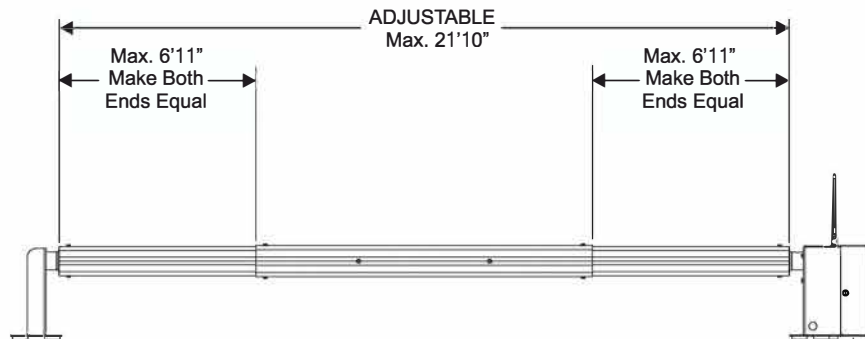

Tube Assembly

1. The tube set will be made from 3 tube sections that are each 7'11" long.
2. The tube set when finished will have a maximum length of 21'10".
3. 2 sections are slightly smaller in diameter and will each slide into one end of the larger diameter tube section (the center tube).
4. Line up the scribe mark on each section and insert one smaller tube into each end of the larger tube.
5. Each smaller tube must be inserted a **minimum** of 12 inches but may be inserted more depending on the width of the pool. The minimum insertion is reached by having no more than 6' 11" of exposed smaller tube showing. **See Diagram.**
6. **The finished tube set should be no more than 2' longer than the width of the pool.**
7. Lock tubes together by rotating the center tube in the opposite direction to end tube. **HOLD TUBES LOCKED WHILE YOU INSTALL FIRST SELF-DRILLING SCREW ON A DRILL LINE, 1" (2.5 cm) back from end of center tube at Location "C1" (see diagram below).**
8. Place 2 more self-drilling screws at Location "C2" & "C3" - 1 screw at every second drill line around tubes.
9. At "D" locations install 3 screws around the center tube at every second drill line. "D" is 10" back from center tube seam.
10. Repeat for other end tube.

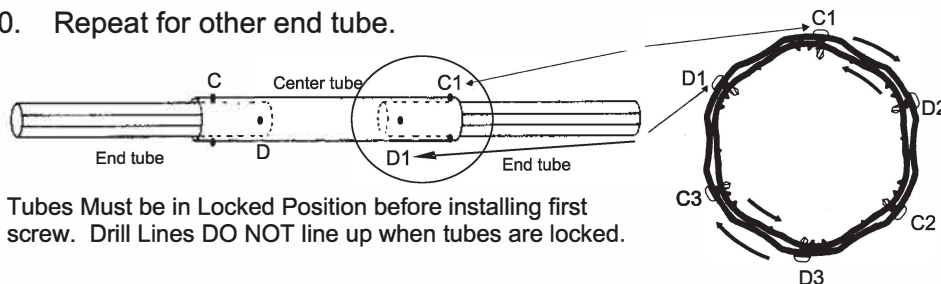

Tubes Must be in Locked Position before installing first screw. Drill Lines DO NOT line up when tubes are locked.

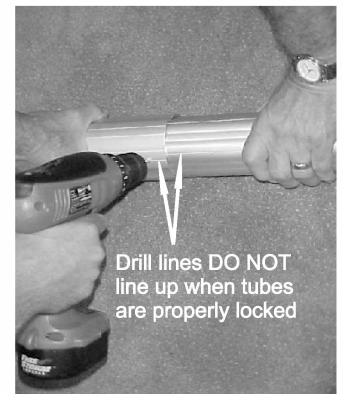

11. Slide the finished cross tube assembly on to the plastic hubs of both the drive side and idle side reel stands. Push the tube on till the edge of the tube is even with the inside edge of the hub (closest to the reel).

12. The internal ribs of the cross tube will score the hubs and hold the tube in place. 2 screws may be placed through the tube and into the plastic hubs at each end if desired.

3) Electrical Connections

1. Mount the power supply box: Securely mount the power supply to a vertical surface a minimum of one (1) foot above the ground/deck level and 10 feet from the pool. The power supply must be connected to a GFI protected receptacle.
2. Plug the motor harness into the connector at the bottom of the power supply.
3. Route the motor harness to the POOL BOY® drivestand.
4. Feed the motor harness into the drive stand on the cutout on the desired side.

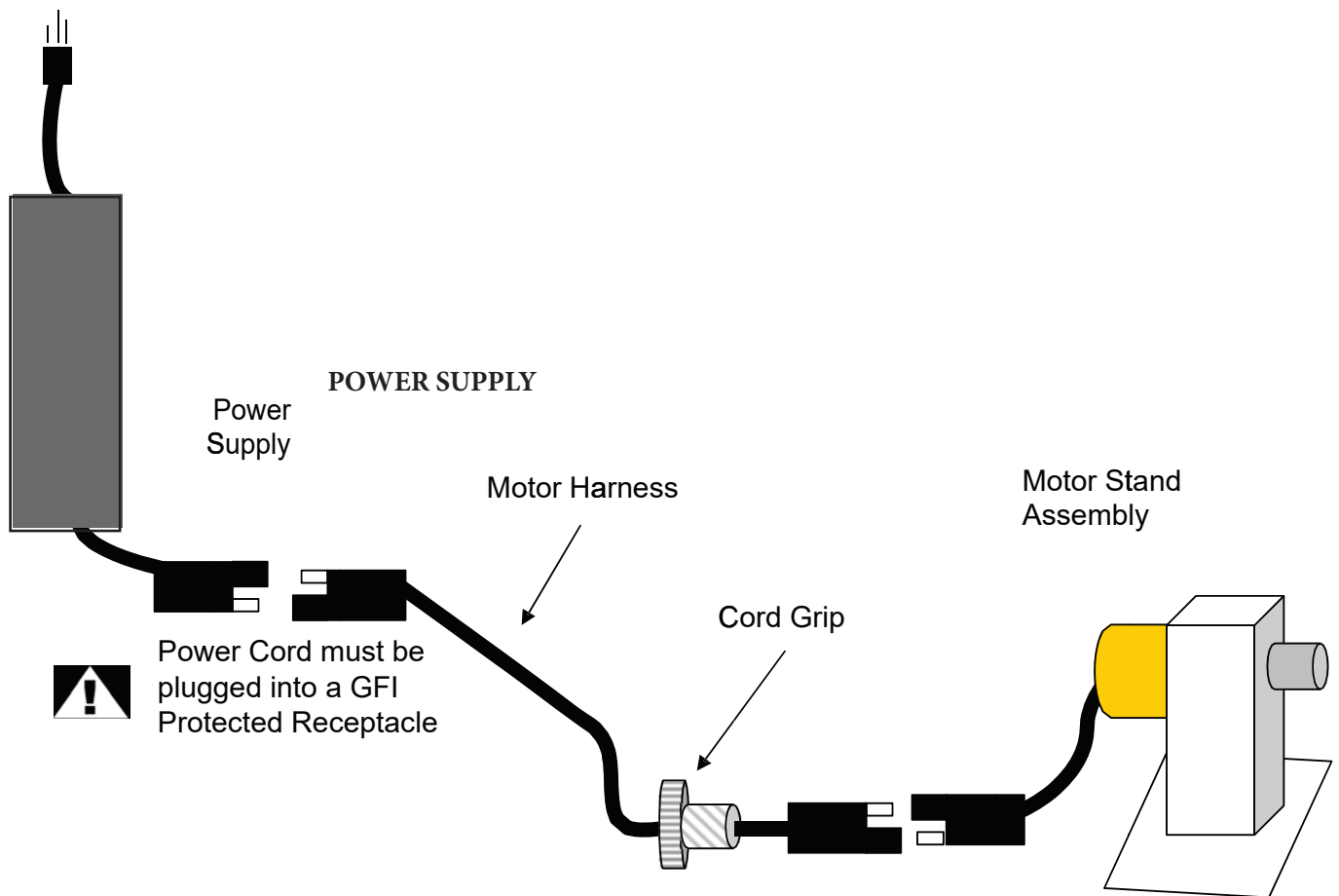

5. Install strain relief / cord grip on bracket in the base of the motor stand. Thread the motor harness through the bracket. Install the jamb nut and tighten.

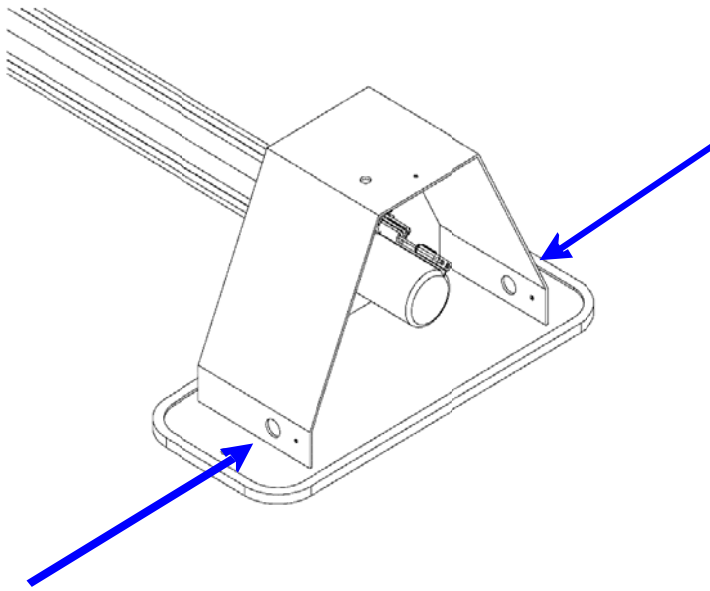

6. Plug motor harness into the connector plug at the motor assembly.
7. Ground motor and idler stands according to local electrical codes. A grounding terminal is provided on each end stand.

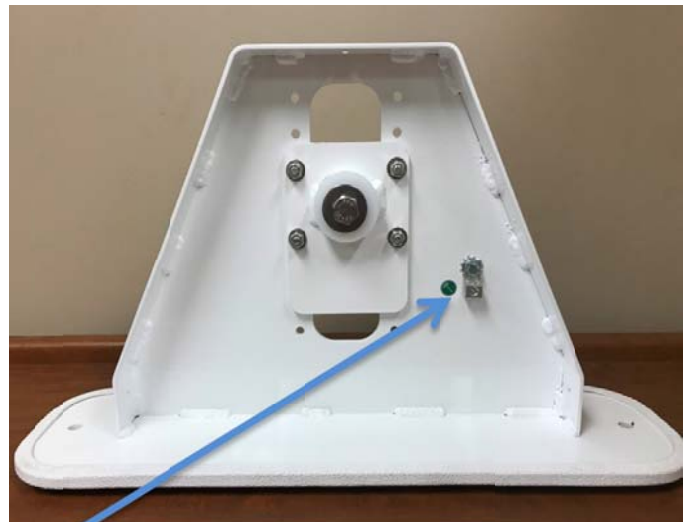
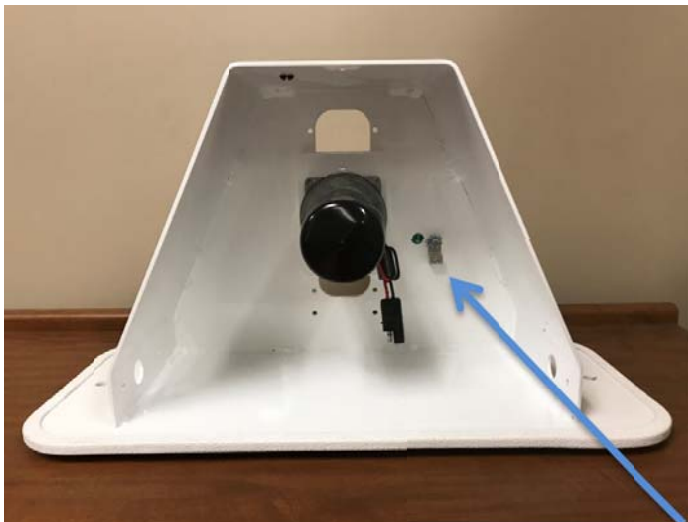

Grounding Terminals

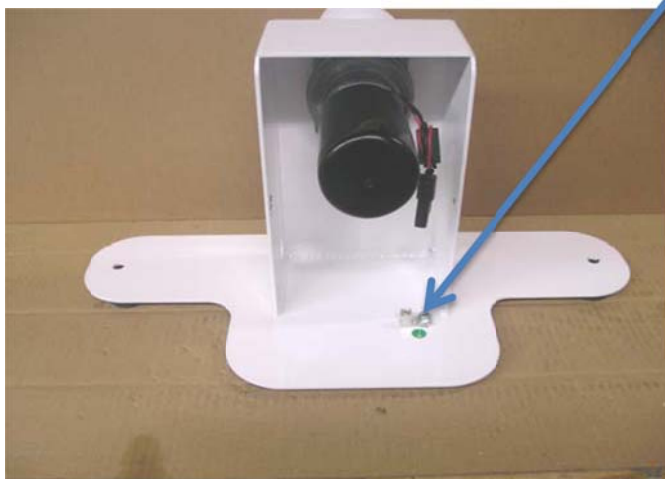

4) Test Run

Plug the power supply into a GFI equipped receptacle. With the cross tubes attached, test run the system. (See the OPERATION Section for instructions.) Ensure the cross tube is securely attached to the Pool Boy® hubs and that it runs smoothly without wobble.

5) Install the covers for the drive and idler stands

Install the drive stand cover. Make sure the motor harness is routed through the slot in the side of the cover. If the idler stand cover was removed, reinstall it at this time.

6) Attach the Solar Blanket

1. CONNECTING THE SOLAR COVER TO THE REEL

(Refer to Step #1)

1. Select a location suitable for pool cover removal, usually on the pool end without steps. Make sure the Solar Cover is trimmed properly. The tube should be positioned perpendicular to the center line of the pool as in Step #1. PROPER ALIGNMENT BETWEEN POOL COVER AND THE TUBE IS CRITICAL! Whether your pool is rectangular or irregular in shape, the straps must be placed and installed so that there is equal pull on all straps at the same time to help prevent misalignment of the cover.

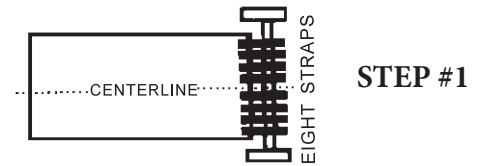

2. ATTACH COVER PLATES TO SOLAR BLANKET

(Refer to Step #2)

1. Starting at one side of the solar cover, position a set of cover plates (male and female) with the large center slot at the location of the blue strap and at least 2" from any edge of the cover.
2. With a sharp instrument, using the female plate as a guide and with the raised ridges facing DOWNWARD, punch 3 holes through the cover plate and cover. The holes must be as wide as the holes in the plate.
3. Place a male plate under the cover directly beneath the female plate.
4. Insert the 2 snaps through the cover and snap together. If the plates do not snap into position with normal force, remove excess cover material.
5. Repeat this operation until all the plates have been installed on the cover.

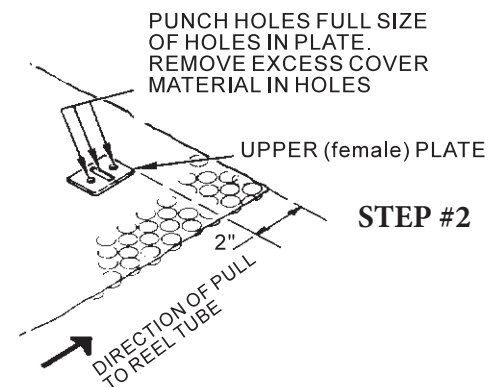

3. ATTACH STRAP / STRAP BUCKLE

(Refer to Steps #3, #4, and #5)

1. With the ribbed crossbar on the strap buckle facing up, slide the buckle onto the strap from the end opposite the velcro.
2. Position the buckle at least 24" from the strap end. Bring the strap underneath the solar cover and up through the center opening in the plate.
3. Thread the strap end back through the buckle.
4. Repeat process for each strap.

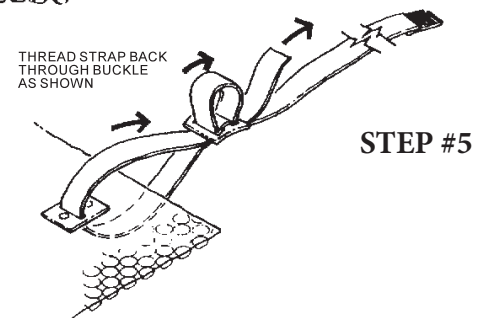
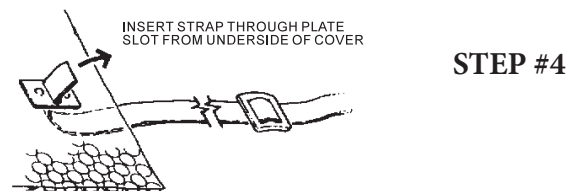
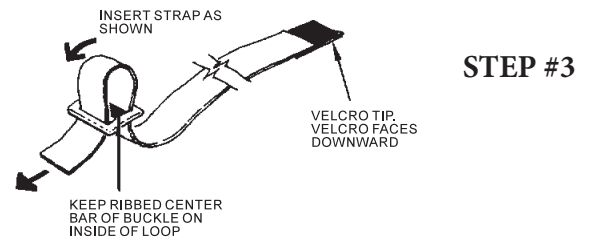

4. ATTACH VELCRO HOOK TO ALUMINUM TUBE

(Refer to Step #6)

1. Place the velcro end of the strap over the tube.
2. Standing behind the tube, pull the strap taut and align as straight as possible between the cover plate and the tube.
3. Remove adhesive backing from the velcro tab and place it firmly into position at the top of the tube. Tube must be dry and free from grease or dirt.
4. Repeat procedure for each strap keeping the velcro adhesive tape in a line along the top of the tube.
5. Use the buckles to adjust each strap so all straps provide equal tension on the solar cover when rolling the solar cover onto the reel.

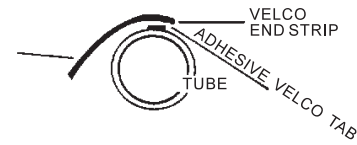

STEP #6

7) Install tether kit

The tether kit attaches to the leading edge of the solar cover, opposite the end that wraps onto the cross tube. The tether kit is used to guide the cover during extension and retraction.

1. Carefully wrap the edge of the cover around the rods (2) 5ft pieces. Ensure the wrap is **even and square** to the leading edge and center of the cover.
2. Install the supplied (6) clips as shown in the following diagram. Bolt through the cover material, a hole will need to be made thru the blanket. Install clamps evenly, approximately one every two feet.
3. Snap the guide rope harness to the clips as shown.

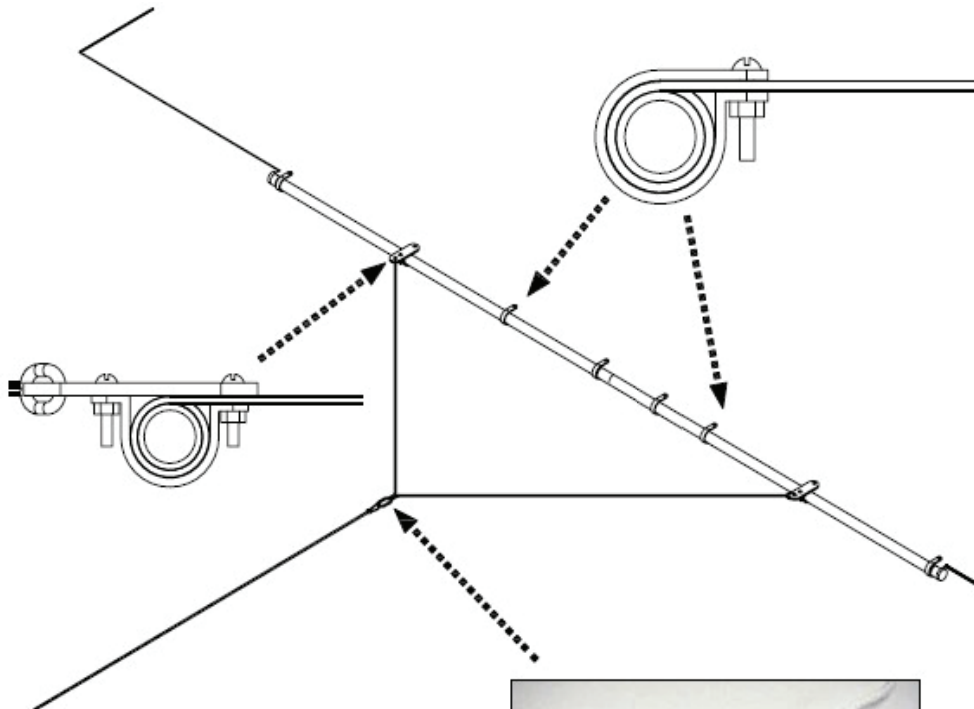

OPERATION OF THE REEL

Safety Items prior to operation

Visually inspect the pool prior to retracting or extending the solar blanket. Ensure that the pool is clear of occupants and that no items will conflict with the solar blanket.

When not in use, store the remote control and system key in a secure location in order to prevent unauthorized operation.

Remote Control

1. The key fob remote control is used to extend and retract the solar blanket.
2. The fob has 4 buttons; A, B, C & D. Only buttons A and B will be used.
3. Depressing button A will make the cross tube rotate in one direction. Depressing button B will make the cross tube rotate in the opposite direction.
4. The button used to retract the solar blanket will depend on which side of the pool the drive side of the Reel is placed. The other button will extend the solar blanket.

Operate the System

1. To retract the blanket, press and hold the appropriate button. Release the button once the solar blanket is rolled up onto the cross tube.
2. To extend the solar blanket back onto the pool press and hold the appropriate button.
3. It will be necessary to guide the blanket onto the pool as it uncoils from the reel. This can be done using the tether. If not using the tether simply grasp a corner of the blanket and walk along the side of the pool assisting the blanket to extend.
4. Release the button once the cover is fully extended.
5. When not in use store the remote control in a safe place that prevents unauthorized use and loss.

Programming Remote Control

1. Linking the remote control fob with the radio receiver in the drive side stand can only be done at the factory.
2. 2 remote control fobs have been included with the reel. Losing both will require purchasing a new fob and returning the radio receiver to the factory to have them linked. There will be a charge for this.



MANUAL OVERRIDE

In the event of a loss of power, a manual override is provided.

- 1) Unplug the power supply from the GFI protected outlet.
- 2) Unplug the motor harness at one of the connections.
- 3) Remove the cover of the idler stand.
- 4) Use a $\frac{3}{4}$ -inch wrench or socket to turn the reel in the desired direction.

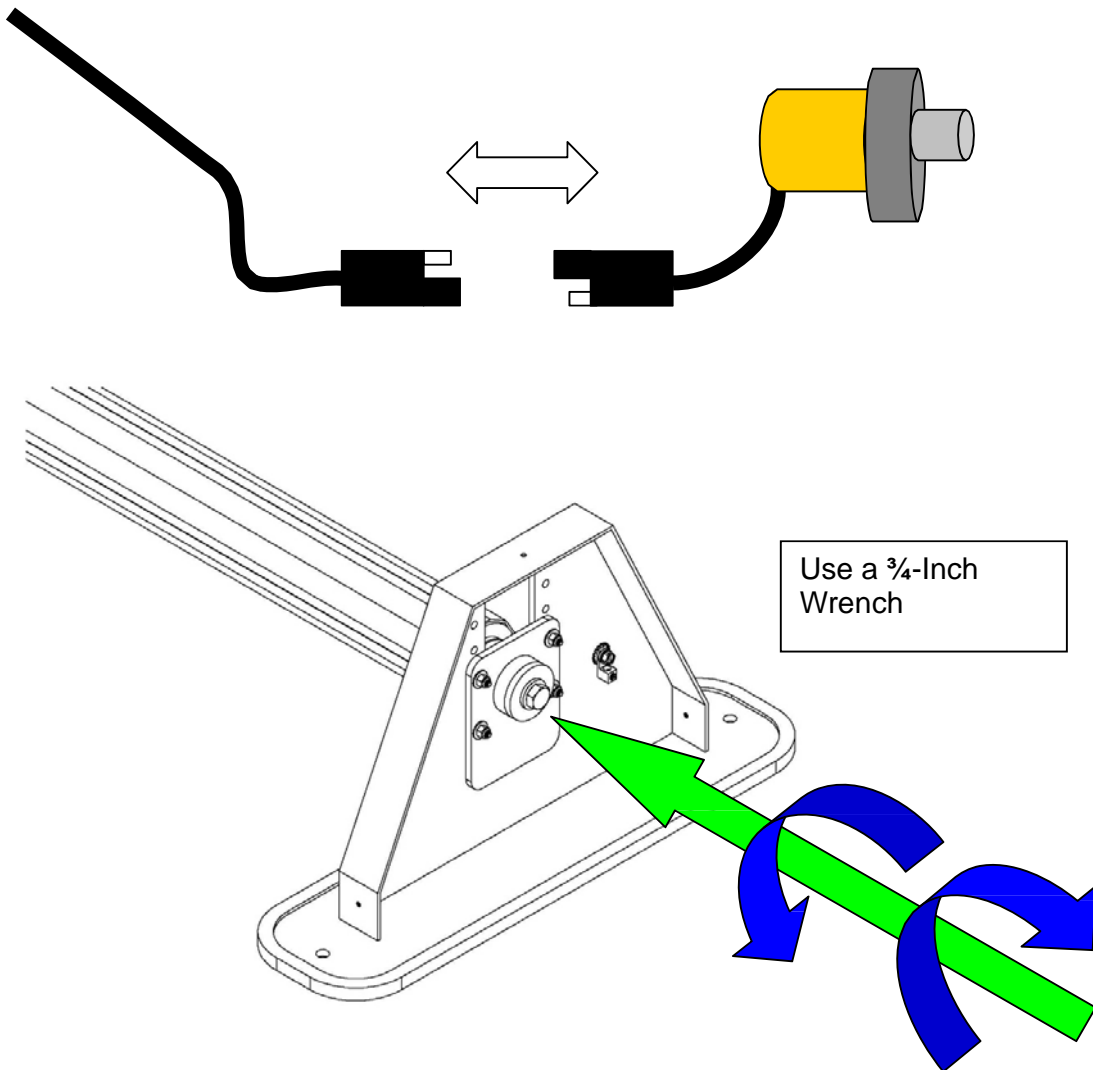

WARRANTY

POOL BOY CORPORATION LIMITED WARRANTY, REPLACEMENT PARTS & RETURNS POLICY POOL BOY®

POOL BOY® LIMITED WARRANTY Effective April 1, 2019 Pool Boy Corporation warrants to the original purchaser of POOL BOY® system components (the "Products"), for a period of three (3) years from the original sale date or date of dealer installation, whichever is earlier ("Limited Warranty Period"), that the Products shall be free from defects in material and workmanship. This is a prorated warranty. Pool Boy's sole obligation under this warranty is, at its election, to repair, replace or make appropriate adjustments concerning the Products where Pool Boy's inspection discloses any such defects in the Products occurring in normal usage within the limited warranty period. Pool Boy will, at its option repair or replace such part at the following prorated cost to the original reel owner:

YEAR 1	NO COST
YEAR 2	35% OF LIST PRICE
YEAR 3	75% OF LIST PRICE

However, you will be responsible for all shipping or transportation costs in connection with transporting this unit to and from Pool Boy. Only warranty claims with prior authorization from Pool Boy will be recognized; all other claims are invalid and will be denied. This warranty does not apply to abuse, misuse, neglect, negligence, error of operations or to purposeful or accidental damage or damage due to "act of God" such as wind or rain damage, flood, lightning or other natural or similar occurrences. The POOL BOY® limited warranty coverage applies only to the Products and no other apparatus or property to which the Products are affixed or attached. The POOL BOY® limited warranty is not transferable. THE FOREGOING WARRANTY IS IN LIEU OF AND EXCLUDES ALL OTHER WARRANTIES NOT EXPRESSLY SET FORTH HEREIN, WHETHER EXPRESS OR IMPLIED BY OPERATION OF LAW OR OTHERWISE, AND POOL BOY is not responsible for removal or installation costs. UNDER NO CIRCUMSTANCES SHALL POOL BOY'S LIABILITY FOR ANY DEFECT IN THE PRODUCTS, WHETHER BASED ON CONTRACT, TORT, WARRANTY, STRICT LIABILITY, OR ANY OTHER THEORY, EXCEED THE PURCHASE PRICE OF THE DEFECTIVE PRODUCTS, AND POOL BOY SHALL HAVE NO LIABILITY FOR CONSEQUENTIAL, SPECIAL, INCIDENTAL, INDIRECT, EXEMPLARY OR PUNITIVE DAMAGES OF ANY KIND WHATSOEVER. This limited warranty provides the limited purchaser of the Products with specific legal rights. The original purchaser of the Products may also have other rights that vary from state to state.

APPLICABILITY OF LIMITED WARRANTY TO REPLACEMENT PARTS. The terms and conditions of the POOL BOY® Limited Warranty shall apply to any replacement parts provided to the original purchaser by Pool Boy in connection with any warranty claim. Any replacement part is warranted for the balance of the Limited Warranty Period or ninety (90) days from the date of shipment of the replacement part, whichever is longer. No markup will be paid by Pool Boy for warranty parts.

RETURNS POLICY. This returns policy applies to all Products returned to Pool Boy from the original purchaser during the Limited Warranty Period. Prior authorization is required before any Product may be returned to Pool Boy. A Return Authorization Number is required for Pool Boy's acceptance of returned Products. Warranty claims submitted without proof of the original purchase date are not covered by this Warranty and will be denied. Parts credit (if applicable) will be sent after Pool Boy tests the Product and validates the warranty claim.

Please direct all questions concerning the POOL BOY® Limited Warranty to:

Pool Boy Corporation
Warranty Claims
5050 W. Lake St.
Chicago, IL 60644
Telephone: 1-866-778-7665
Email: poolboyreels@gmail.com

